

Drawings

ADMAG TI Series
 AXW Magnetic Flowmeter
 [Size: 500 to 1000 mm (20 to 40 in.)]
 Flange EN PN10 (Process Connection Code CE1)



SD 01E25D11-03EN

[Style: S2]

Unit: mm (approx. in.)

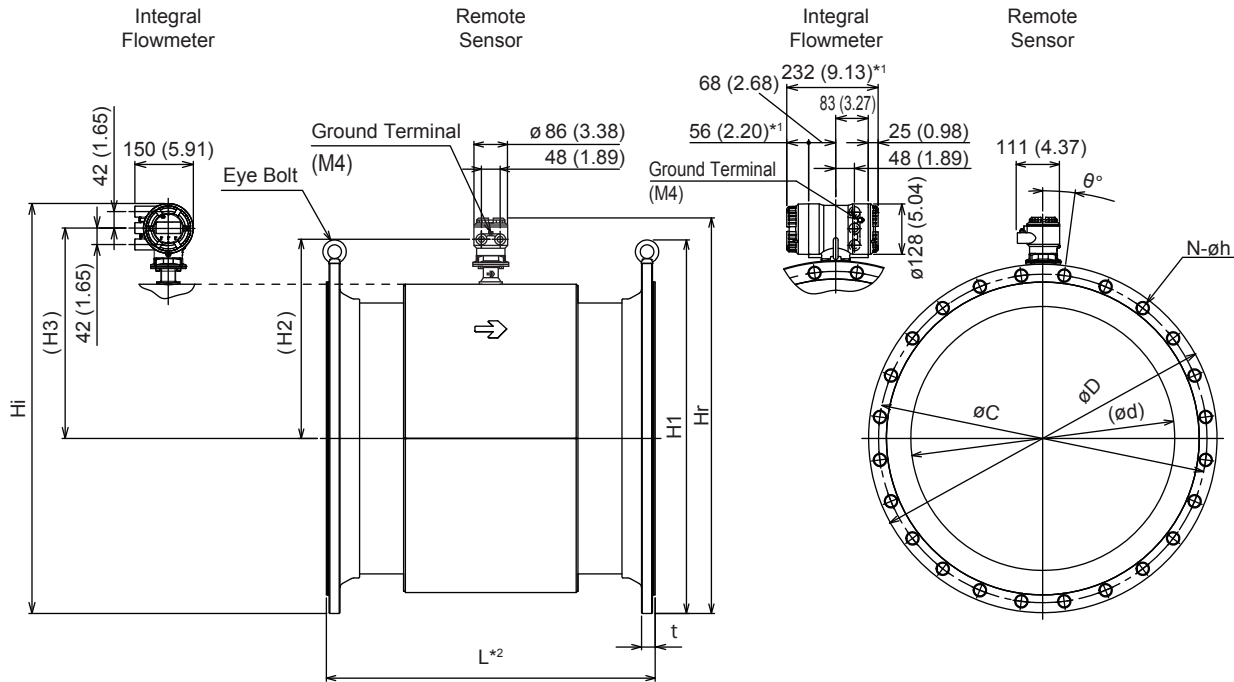

*1: This length becomes 21 mm (0.83 in.) shorter when indicator code N is selected.

F01.ai

*2: The thickness of optional grounding rings (4mm per one) and customer supplied gaskets are not included in "L" here.

	Direction of Cable Entry			
	Standard (0°)	+90° rotation Optional Code RA	+180° rotation Optional Code RB	-90° rotation Optional Code RC
Integral Flowmeter				
Remote Sensor				

* The direction of cable entry changes as shown left depending on the designation of the optional code RA, RB, or RC.

Unless otherwise specified, difference in the dimensions are specified as : General tolerance = ± (Criteria of tolerance class IT18 in JIS B0401-1) / 2

Model code:

AXW - - CE1N -

Unit: mm (approx. in.)

Process Connection Code	CE1					
Flange Type	EN1092-1 PN10					
Size Code	500	600	700	800	900	10L
Size	500 (20)	600 (24)	700 (28)	800 (32)	900 (36)	1000 (40)
Lining Code	H, F, U, D					
Lay Length L	600 (23.62)	720 (28.35)	840 (33.07)	960 (37.80)	1080 (42.52)	1200 (47.24)
Flange Outer Diameter \varnothing D	670 (26.38)	780 (30.71)	895 (35.24)	1015 (39.96)	1115 (43.90)	1230 (48.43)
Flange Thickness (*1) (incl. lining flare)	Lining F	33 (1.30)	33 (1.30)	35 (1.38)	37 (1.46)	39 (1.54)
	Lining H, D	31.5 (1.24)	31.5 (1.24)	33.5 (1.32)	35.5 (1.4)	37.5 (1.48)
	Lining U	34 (1.34)	34 (1.34)	36 (1.42)	38 (1.50)	40 (1.57)
Bolt Circle Diameter \varnothing C	620 (24.41)	725 (28.54)	840 (33.07)	950 (37.40)	1050 (41.34)	1160 (45.67)
Inner Diameter \varnothing d	Lining H, F, D	477 (18.78)	578 (22.76)	675 (26.57)	777 (30.59)	878 (34.57)
	Lining U	469 (18.46)	570 (22.44)	667 (26.26)	769 (30.28)	870 (34.25)
Bolt Hole Pitch Half Angle θ	9°	9°	7.5°	7.5°	6.4°	6.4°
Bolt Hole Diameter \varnothing h	26 (1.02)	30 (1.18)	30 (1.18)	33 (1.30)	33 (1.30)	36 (1.42)
Number of Bolt Holes N	20	20	24	24	28	28
Height H1	730 (28.74)	840 (33.07)	955 (37.60)	1086 (42.76)	1186 (46.69)	1320 (51.97)
Height H2	401 (15.80)	452 (17.80)	501 (19.73)	552 (21.74)	604 (23.77)	655 (25.78)
Height Hr	790 (31.09)	896 (35.26)	1002 (39.46)	1113 (43.83)	1215 (47.82)	1323 (52.09)
Inner Diameter of Eye Bolt	35 (1.38)	35 (1.38)	35 (1.38)	40 (1.57)	40 (1.57)	50 (1.97)
Remote Sensor, Approx. Weight, Unit: kg (lb) (*2)	170 (375)	232 (511)	285 (628)	380 (838)	491 (1082)	646 (1424)
Integral Flowmeter, Height H3	438 (17.24)	489 (19.26)	538 (21.20)	590 (23.21)	641 (25.24)	692 (27.25)
Integral Flowmeter, Maximum Height Hi	836 (32.91)	942 (37.09)	1049 (41.30)	1160 (45.67)	1262 (49.67)	1370 (53.94)
Integral Flowmeter, Approx. Weight, Unit: kg (lb)	173 (381)	235 (518)	288 (635)	383 (844)	494 (1089)	649 (1431)

*1: The tolerance of the flange thickness "t" is as follows.

• Size 500 to 1000 mm (20 to 40 in.): +3/-2 mm (+0.12/-0.08 in.)

*2: When submersible type or optional code DHC is selected, waterproof glands with union joints and cables are attached. When the cable length is 30-meters, add 9.5 kg (20.9 lb) to the weight in the table.

Terminal Configuration and Wiring

Remote Sensor:

<To be wired to Remote Transmitter>

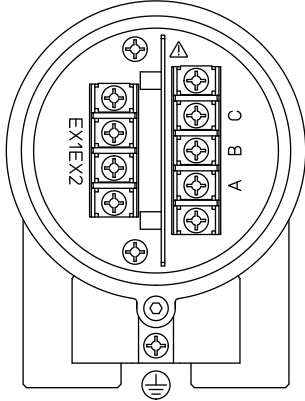

Terminal Symbol	Description
A B C	Flow Signal Output
EX1 EX2	Excitation Current Input
⊕	Protective Grounding (Outside of the terminal box)

F02.ai

Note: When submersible use or optional code DHC is selected, waterproof glands with union joints and cables are attached.

Integral Flowmeter:

<To be wired to Power Supply and I/Os>

M4 Screw Type

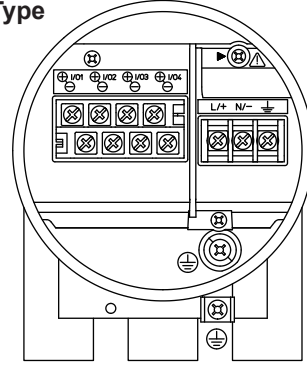

Clamp Type

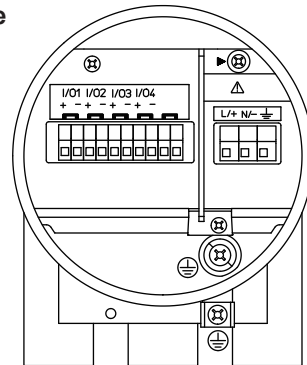

Terminal Symbol	Description
▶	Shorting Screw (Need to be fixed for normal operation)
⊕	Functional Grounding
N/ L/+	Power Supply
I/O4 - I/O4 + I/O3 - I/O3 + I/O2 - I/O2 + I/O1 - I/O1 +	Selected Input/Output
⊕	Protective Grounding (Inside and outside of the terminal box)

F03.ai

Flange EN PN10 (Process Connection Code CE1) [Style: S1]

Unit: mm (approx. in.)

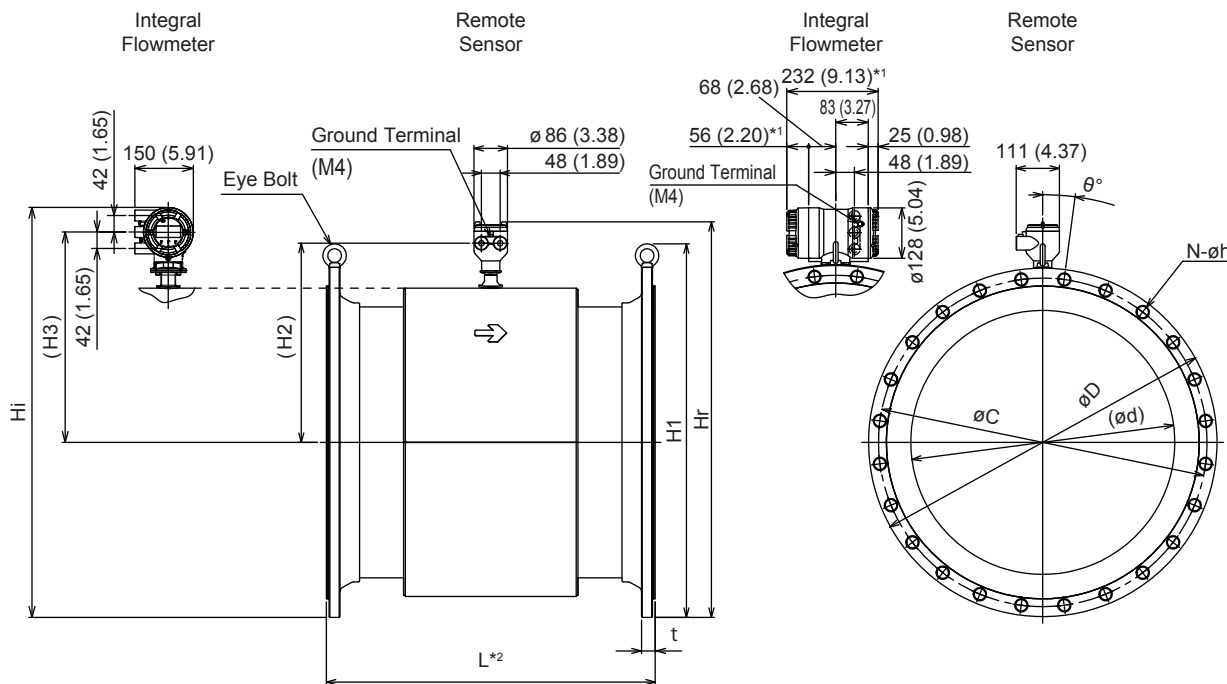

*1: This length becomes 21 mm (0.83 in.) shorter when indicator code N is selected.

F04.ai

*2: The thickness of optional grounding rings (4mm per one) and customer supplied gaskets are not included in "L" here.

	Direction of Cable Entry			
	Standard (0°)	+90° rotation Optional Code RA	+180° rotation Optional Code RB	-90° rotation Optional Code RC
Integral Flowmeter				
Remote Sensor				

* The direction of cable entry changes as shown left depending on the designation of the optional code RA, RB, or RC.

Unless otherwise specified, difference in the dimensions are specified as : General tolerance = ± (Criteria of tolerance class IT18 in JIS B0401-1) / 2

Model code:AXW - - CE1N -

Unit: mm (approx. in.)

Process Connection Code	CE1					
Flange Type	EN1092-1 PN10					
Size Code	500	600	700	800	900	10L
Size	500 (20)	600 (24)	700 (28)	800 (32)	900 (36)	1000 (40)
Lining Code	H, F, U, D					
Lay Length L	600 (23.62)	720 (28.35)	840 (33.07)	960 (37.80)	1080 (42.52)	1200 (47.24)
Flange Outer Diameter \varnothing D	670 (26.38)	780 (30.71)	895 (35.24)	1015 (39.96)	1115 (43.90)	1230 (48.43)
Flange Thickness (*1) (incl. lining flare)	Lining F	33 (1.30)	33 (1.30)	35 (1.38)	37 (1.46)	39 (1.54)
	Lining H, D	31.5 (1.24)	31.5 (1.24)	33.5 (1.32)	35.5 (1.4)	37.5 (1.48)
	Lining U	34 (1.34)	34 (1.34)	36 (1.42)	38 (1.50)	40 (1.57)
Bolt Circle Diameter \varnothing C	620 (24.41)	725 (28.54)	840 (33.07)	950 (37.40)	1050 (41.34)	1160 (45.67)
Inner Diameter \varnothing d	Lining H, F, D	477 (18.78)	578 (22.76)	675 (26.57)	777 (30.59)	878 (34.57)
	Lining U	469 (18.46)	570 (22.44)	667 (26.26)	769 (30.28)	870 (34.25)
Bolt Hole Pitch Half Angle θ	9°	9°	7.5°	7.5°	6.4°	6.4°
Bolt Hole Diameter \varnothing h	26 (1.02)	30 (1.18)	30 (1.18)	33 (1.30)	33 (1.30)	36 (1.42)
Number of Bolt Holes N	20	20	24	24	28	28
Height H1	730 (28.74)	840 (33.07)	955 (37.60)	1086 (42.76)	1186 (46.69)	1320 (51.97)
Remote Sensor, Height H2	408 (16.06)	459 (18.07)	509 (20.04)	560 (22.05)	611 (24.06)	662 (26.06)
Remote Sensor, Maximum Height Hr	797 (31.38)	903 (35.51)	1011 (39.80)	1122 (44.17)	1223 (48.15)	1331 (52.40)
Inner Diameter of Eye Bolt	35 (1.38)	35 (1.38)	35 (1.38)	40 (1.57)	40 (1.57)	50 (1.97)
Remote Sensor, Approx. Weight, Unit: kg (lb) (*2)	170 (375)	232 (511)	285 (628)	380 (838)	491 (1082)	646 (1424)
Integral Flowmeter, Height H3	438 (17.24)	489 (19.26)	538 (21.20)	590 (23.21)	641 (25.24)	692 (27.25)
Integral Flowmeter, Maximum Height Hi	836 (32.91)	942 (37.09)	1049 (41.30)	1160 (45.67)	1262 (49.67)	1370 (53.94)
Integral Flowmeter, Approx. Weight, Unit: kg (lb)	173 (381)	235 (518)	288 (635)	383 (844)	494 (1089)	649 (1431)

*1: The tolerance of the flange thickness "t" is as follows.

• Size 500 to 1000 mm (20 to 40 in.): +3/-2 mm (+0.12/-0.08 in.)

*2: When submersible type or optional code DHC is selected, waterproof glands with union joints and cables are attached. When the cable length is 30-meters, add 9.5 kg (20.9 lb) to the weight in the table.

Terminal Configuration and Wiring

Remote Sensor:

<To be wired to Remote Transmitter>

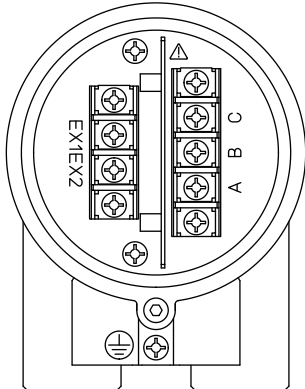

Terminal Symbol	Description
A B C	Flow Signal Output
EX1 EX2	Excitation Current Input
⊕	Protective Grounding (Outside of the terminal box)

F05.ai

Note: When submersible use or optional code DHC is selected, waterproof glands with union joints and cables are attached.

Integral Flowmeter:

<To be wired to Power Supply and I/Os>

M4 Screw Type

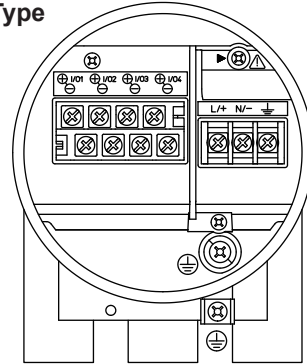

Clamp Type

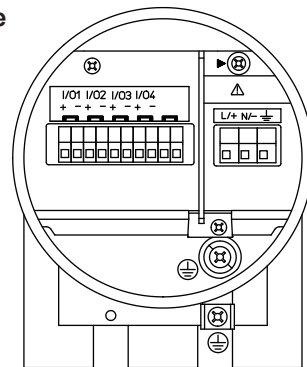

Terminal Symbol	Description
▶	Shorting Screw (Need to be fixed for normal operation)
⊕	Functional Grounding
N/ L/+	Power Supply
I/O4 - I/O4 + I/O3 - I/O3 + I/O2 - I/O2 + I/O1 - I/O1 +	Selected Input/Output Pulse/Status Output 1 Current Output 1
⊕	Protective Grounding (Inside and outside of the terminal box)

F06.ai