

DCS800

Quick guide
DCS800 Drives (20 A to 5200 A)



DCS800 QUICK GUIDE

english	Contents
DC Drives Worldwide Service Network	3
DCS800 Drive Manuals	4
DCS800 DC Drives.....	5
Brief instructions for CD and documents overview	7
Notes on EMC.....	8
Standard function assignments for the terminals.....	10
Connection example.....	11
Fan power connection.....	13
Terminal locations on the converter.....	14
Notes For North American Installations.....	15
Safety and operating instructions	17
Installing the DCS800 PC tools on Your computer.....	18
Commissioning.....	19
DCS800 Control Panel	20
Dimensions, drilling patterns and weights	77
Fault / Alarm list	79
Diagnosis messages.....	88
Macro & Firmware structure.....	93
Declaration of conformity.....	106
Certificate of manufacture	107

español	Contenido
Red de atención mundial de convertidores de CC	3
Manuales de convertidores DCS800.....	4
Convertidores de CC DCS800	49
Instrucciones para la descripción del CD y documentación	51
Notas acerca de EMC	52
Asignaciones de funciones estándar para los terminales... ..	54
Ejemplo de conexión	55
Conexión de alimentación del ventilador	57
Ubicación de los terminales en el convertidor	58
Instrucciones de seguridad.....	59
Cómo instalar las herramientas para PC del DCS800	60
Puesta en funcionamiento	61
Panel de control del DCS800	62
Dimensiones, patrones de taladrado y pesos.....	77
Lista de fallos/alarmas	79
Mensajes de diagnóstico	88
Estructura del macro & firmware.....	93
Declaración de conformidad.....	106
Certificate of manufacture.....	107

deutsch	Inhalt
DC Drives Worldwide Service Network	3
DCS800 Drive Manuals	4
DCS800 Gleichstromantriebe	21
Kurzanweisung CD und Documentations[bersicht	23
EMV Filter	24
Digitaler und analoger E-A/Anschluss von SDCS-CON-4..	26
Anschlussbeispiel	27
Lüfterkühlung	29
Klemmen- und Steckeranordnung des Stromrichters.....	30
Sicherheits- und Anwendungshinweise.....	31
Installation der DCS800 Programme auf dem PC	32
Inbetriebnahme	33
DCS800 Steuertafel.....	34
Abmessungen, Bohrbild und Gewichte	77
Fehler- und Alarmliste	79
Diagnose.....	88
Macro & Firmware Struktur	93
Declaration of conformity.....	106
Herstellerbescheinigung	107

français	Sommaire
DC Drives Worldwide Service Network	3
Manuels du DCS800 (originaux anglais).....	4
Variateurs à courant continu DCS800	63
Documentation technique	65
Compatibilité électromagnétique (CEM)	66
Raccordement standard des signaux d'E/S.....	68
Exemple de schéma de câblage.....	69
Câblage du ventilateur.....	71
Emplacement des bornes sur le convertisseur	72
Consignes de sécurité et d'exploitation.....	73
Installation des outils logiciels du DCS800 sur votre PC....	74
Mise en service.....	75
Micro-console DCS800	76
Dimensions, perçages et poids	77
Liste des défauts / alarmes	79
Messages de diagnostic.....	88
Structure du logiciel macro & système	93
Déclaration de conformité.....	106
Certificat du fabricant	107

italiano	Indice
DC Drives Worldwide Service Network	3
DCS800 Drive Manuals / DCS800 Manuali Drive	4
DCS800 DC Drives.....	35
Brevi istruzioni CD e documentazione.....	37
Note sulle EMC.....	38
Assegnazione funzioni standard per i morsetti	40
Esempi schemi di collegamento.....	41
Fan power connection.....	43
Terminal locations on the converter.....	44
Istruzioni per la sicurezza e il funzionamento	45
Installa i DCS800 PC tools sul Tuo computer	46
Messa in servizio	47
Descrizione display	48
Disegni dimensionali	77
Fault / Alarm list	79
Diagnosis messages.....	88
Struttura macro & firmware.....	93
Dichiarazione di conformità.....	106
Certificato del costruttore	107

ABB Drive Service EN

In order to offer the same after sales service to our customer around the world, ABB has created the DRIVE SERVICE CONCEPT.

ABB's after sales service is globally consistent due to common targets, rules, and the way of operation. This means for our customers:

Please visit the ABB *drive service homepage*

www.abb.com/drivesservices

ABB Drive Service FR

Pour offrir la même qualité de service à tous nos clients, ABB a créé DRIVE SERVICE CONCEPT.

Dans le monde entier, les équipes de service proposent les mêmes prestations aux mêmes conditions avec les mêmes objectifs.

Pour en savoir plus, connectez-vous sur ABB *drive service homepage*

www.abb.com/drivesservices

ABB Drive Service DE

Um jedem Kunden rund um die Welt die gleiche Service Dienstleistung anbieten zu können, hat ABB das DRIVE SERVICE CONCEPT entwickelt.

Durch die Definition von einheitlichen Zielen, Regeln, und Arbeitsvorschriften kann ABB die Dienstleistungs Produkte weltweit auf gleichwertig hohem Qualitätsniveau anbieten. Für unsere Kunden bedeutet dies:

Bitte besuchen Sie die ABB-Homepage *Service für Antriebe*

www.abb.com/drivesservices

ABB Drive Service IT

ABB ha creato il DRIVE SERVICE CENCEPT, con lo scopo di offrire ai nostri clienti lo stesso servizio post vendita in tutto il mondo.

Attraverso la definizione di obiettivi comuni, ruoli e modo di operare, le attività post vendita di ABB offrono servizi coerenti nella loro globalità. Per i nostri clienti questo significa:

Vi invitiamo a visitare la homepage ABB *drive service*

www.abb.com/drivesservices

ABB Drive Service ES

Para poder ofrecer el mismo servicio posventa a nuestros clientes en todo el mundo, ABB ha creado el CONCEPTO DE SERVICIO DE CONVERTIDORES.

El servicio posventa de ABB está mundialmente consolidado gracias a unos objetivos y normas comunes, así como a su funcionamiento. Esto significa para nuestros clientes:

Visiten el portal de *convertidores de ABB*

www.abb.com/drivesservices



DC Drives Worldwide Service Network

Country	Local ABB Service	Town	Service Phone No.
Argentina	Asea Brown Boveri S.A.	BUENOS AIRES	+54 (0) 12 29 55 00
Australia	ABB	NOTTING HILL	+61 (0) 3 85 44 00 00
Austria	ABB AG	WIEN	+43 1 60 10 90
Belgium	ABB N.V.	ZAVENTEM	+32 27 18 64 86 +32 27 18 65 00 - 24h service
Brazil	ABB Ltda.	OSASCO	+55 (0) 11 70 84 91 11
Canada	ABB Inc.	SAINT-LAURENT	+1800 865 7628
China	ABB China Ltd	BEIJING	+86 40 08 10 88 85 - 24h service
Czech Republic	ABB S.R.O.	PRAHA	+42 02 34 32 23 60
Finland	ABB Oy Service	KUUSANKOSKI	+35 8 10 22 51 00
Finland	ABB Oy Product Service	HELSINKI	+35 8 10 22 20 00
Finland	ABB Oy Service	NOKIA	+35 8 10 22 51 40
France	ABB Automation ABB Process Industry	MONTLUEL	from abroad France +33 1 34 40 25 81 +0810 02 00 00
Germany	ABB Process Industries	MANNHEIM	+49 18 05 22 25 80
Greece	ABB SA	METAMORPHOSSIS	+30 69 36 58 45 74
Ireland	ABB Ireland Ltd.	TALLAGHT	+35 3 14 05 73 00
Italy	ABB	MILAN	+39 02 90 34 73 91
Korea, Republic	ABB Ltd., Korea	CHONAN	+82 (0) 4 15 29 22
Malaysia	ABB Malaysia Sdn. Bhd.	KUALA LUMPUR	+60 3 56 28 42 65
Mexico	ABB Sistemas S.A. DE C.V.	TLALNEPANTLA	+52 53 28 14 00
Netherlands	ABB B.V.	ROTTERDAM	+31 1 04 07 88 66
New Zealand	ABB Service Ltd	AUCKLAND	+64 92 76 60 16
Poland	ABB Centrum IT Sp.zo.o	WROCLAW LODZ	+48 42 61 34 96 2 +48 42 29 93 91 39 5
Russia	ABB Automation LLC	MOSCOW	+74 95 96 0
Switzerland	ABB AG	DÄTTWIL	+41 5 85 86 87 86
Singapore	ABB Industry Pte Ltd.	SINGAPORE	+65 67 76 57 11
Slovakia	ABB Elektro s.r.o.	BANSKA BYSTRICA	+42 19 05 58 12 78
South Africa	ABB South Africa (Pty) Lt	JOHANNESBURG	+27 1 16 17 20 00
Spain	ABB Automation Products	BARCELONA	+34 9 37 28 73 00
Taiwan	ABB Ltd.	TAIPEI 105	+88 62 25 77 60 90
Thailand	ABB Limited	SAMUTPRAKARN	+66 27 09 33 46
Turkey	ABB Elektirk Sanayi A.S	ISTANBUL	+90 2 16 36 52 90
USA	ABB Industrial Products	NEW BERLIN	+1 26 27 85 32 00 +1 262 435 7365
Venezuela	ABB S.A.	C R C S	+58 (0) 22 38 24 11 / 12

DCS800 Drive Manuals

	Public. number	Language						
		E	D	I	ES	F	CN	RU
DCS800 Quick Guide	3ADW000191	x	x	x	x	x		
DCS800 Tools & Documentation CD	3ADW000211	x						
DCS800 Converter module								
Flyer DCS800	3ADW000190	x	x	x	x	x	x	x
Technical Catalogue DCS800	3ADW000192	x	x	x	x	x	x	x
Hardware Manual DCS800	3ADW000194	x	x	p	x	x	x	x
Hardware Manual DCS800 update DCF503B/DCF504B	3ADW000194Z0301	x						
Firmware Manual DCS800	3ADW000193	x	x	p	x	p	x	x
Installation according to EMC	3ADW000032	x						
Technical Guide	3ADW000163	x						
Service Manual DCS800	3ADW000195	x	x					
12-Pulse Manual	3ADW000196	x						
CMA-2 Board	3ADW000136	p						
Flyer Hard - Parallel	3ADW000213	x						
Drive Tools								
DriveWindow 2.x - User's Manual	3BFE64560981	x						
DriveOPC 2.x - User's Manual	3BFE00073846	x						
Optical DDCS Communication Link	3AFE63988235	x						
DDCS Branching Units - User's Manual	3BFE64285513	x						
DCS800 Applications								
PLC Programming with CoDeSys	CoDeSys_V23	x	x			x		
61131 DCS800 target +tool description - Application Program	3ADW000199	x						
DCS800 Crane Drive								
DCS800 Crane Drive Manual suppl.	3AST004143	x						
DCS800 Crane Drive Product note	PDC5 EN REVA	p						
DCS800 Winder ITC								
DCS800 Winder Product note	PDC2 EN	x						
DCS800 Winder description ITC	3ADW000308	x						
Winder Questionnaire	3ADW000253z	x						
DCS800-E Panel Solution								
Flyer DCS800-E Panel solution	3ADW000210	x						
Hardware Manual DCS800-E	3ADW000224	x						
DCS800-A Enclosed Converters								
Flyer DCS800-A	3ADW000213	x						
Technical Catalogue DCS800-A	3ADW000198	x						
Installation of DCS800-A	3ADW000091	p						
DCS800-R Rebuild System								
Flyer DCS800-R	3ADW000007	x	x					
DCS800-R Manual	3ADW000197	x						
DCS500/DCS600 Size A5...A7, C2b, C3 and C4 Upgrade Kits	3ADW000256	x						
Extension Modules								
RAIO-01 Analogue IO Extension	3AFE64484567	x						
RDIO-01 Digital IO Extension	3AFE64485733	x						
AIMA R-slot extension	3AFE64661442	x						
Serial Communication								
Drive specific serial communication								
NETA Remote diagnostic interface	3AFE64605062	x						
Fieldbus Adapter with DC Drives RPBA- (PROFIBUS)	3AFE64504215	x						
Fieldbus Adapter with DC Drives RCAN-02 (CANopen)								
Fieldbus Adapter with DC Drives RCNA-01 (ControlNet)	3AFE64506005	x						
Fieldbus Adapter with DC Drives RDNA- (DeviceNet)	3AFE64504223	x						
Fieldbus Adapter with DC Drives RMBA (MODBUS)	3AFE64498851	x						
Fieldbus Adapter with DC Drives RETA (Ethernet)	3AFE64539736	x						
x -> existing p -> planned								
Status 10.2008								

DCS800 Drive Manuals-List_h.doc



Standard Features

- compact
- highest power ability
- simple operation
- comfortable assistants, e.g. for autotuning or commissioning
- scalable to all applications
- free programmable by means of integrated IEC61131-PLC

DCS800 DC Drives

Technical data

Mains supply volt.	230...1,200 V, +/-10%, 3~
Frequency	50...60 Hz, +/-5 Hz
Electronics supply	115...230 V, -15% / +10%, 1~
DC Output current	20...5,200 A
Overload capability	200%

Ambient conditions

Ambient temperat.	0° ... +40° C 40° ... 55° C with reduction
Storage temperat.	-40° ... +55° C
Transport temper.	-40° ... +70° C
Relative humidity	5 ... 95%, not condensing (max. 50% betw. 0°...5° C)
Pollution degree	Class 2
Protection class	IP 00
Altitude	< 1,000 m height above sea level: nominal Current > 1,000 m height above sea level: with reduction

I/O

Digital inputs: 8 standard, up to 14 optional
Digital outputs: 8 standard, up to 12 optional
Analog inputs: 4 standard +/-10 V; 0/2...10 V, up to 8 optional +/- 20 mA; 0/4...20 mA
Analog outputs: 3 standard (1x I_{act}) +/-10 V; 0/2...10 V, up to 7 optional -20 mA; 0/4...20 mA

PC-Tools

DriveWindow Light: free of charge with every converter, Standard RS232 PC-connection
DriveWindow: Real-time optical connection
ControlBuilder DCS800: IEC61131 programming tool
DriveSize: Converter- and motor dimensioning

Maintenance / Diagnosis

Remote diagnosis with any Internet-PC worldwide
 • with internet browser / internet explorer
 • or with DriveWindow full drive control via OPC

Approvals



Adaptive Programming

pre-defined drive-specific function blocks, e.g.
 • Free process controller (PI-Controller)
 • I/O- and digital Operations
 With control panel or PC-Tool, no need for additional hardware

Speed Feedback

EMF
 Analogue tachometer
 Encoder
 2nd Encoder possible (RTAC)

Communication

Serial communication
 • Ethernet • Profibus
 • CANopen • DeviceNet
 • ControlNet • DDCS
 • Modbus • AF100
 • CS31 • Selma2
 Industrial IT® enabled

DCSLink Peer-to-Peer

• up to 800 kBaud, < 2.5 ms
 • Master-Follower
 • Armature-fieldconverter
 • Free selectable data

High Current Solutions

• 12-pulse up to 20,000 A, serial and parallel
 • Hard parallel and sequential
 • up to 1,500 V

Protections

Speed feedback monitoring •
 Temperature • Overload • Over speed • Motor stalled • Motor over current • Motor over voltage • Field over current • Field over voltage • Minimum field current • Zero speed • Armature current ripple • Mains over- and under voltage

Integrated IEC 61131-PLC

• Open standard programming tool ControlBuilder DCS800
 • Support of all five IEC-languages
 • Drive-specific function blocks
 • Saving of program and source in Memory Card
 • Online debugging and forcing

Current ratings, dimensions

Unit size	2-Q rated Current DCS800-01 I _{DC} [A]	4-Q rated Current DCS800-02 I _{DC} [A]	Supply voltage [V _{AC}]							max. field current internal [A _{DC}]	Dimensions	
			400	525	600	690	800	990	1200		h x w x d [mm]	h x w x d [inch]
D1	20	25	●	●					6	370 x 270 x 200	14.56 x 10.65 x 7.90	
	45	50	●	●								
	65	75	●	●								
	90	100	●	●								
	125	140	●	●								
D2	180	200	●	●				15	370 x 270 x 270	14.56 x 10.65 x 10.65		
	230	260	●	●								
D3	315	350	●	●	● ³⁾			20	459 x 270 x 310	18.07 x 10,65 x 12,25		
	405	450	●	●								
	470	520	●	●								
D4	610	680	●	●	● ³⁾			25	644 x 270 x 345	25.35 x 10.65 x 13.60		
	740	820	●	●								
	900	1000	●	●								
D5	900	900	●	●	●	●		25	1050 x 510 x 410	41.35 x 20.10 x 16.15		
	1200	1200	●	●								
	1500	1500	●	●	●	●						
	2000	2000	●	●	● ¹⁾	● ¹⁾						
D6	1900	1900		●	●	●	●	external field 35A, 1~/3~ 50/60A, 1~ 520A, 3~	1750 x 460 x 410	68.90 x 18.15 x 16.15		
	2050	2050		●	●	●						
	2500	2500	●	●	●	●						
	3000	3000	●	●	●	●						
D7	2050	2050		●	●	●	●	external field 35A, 1~/3~ 50/60A, 1~ 520A, 3~	1750 x 760 x 570	68.90 x 29.95 x 22.45		
	2600	2600		●	●	●	● ²⁾					
	3300	3300	●	●	●	●	● ²⁾					
	4000	4000	●	●	●	●						
	4800	4800	●	●	●	●						
	5200	5200	●	●								

●¹⁾ only available as 2-Q drive

●²⁾ on request

●³⁾ 600V

2-Q -> 290 A / 590 A
 4-Q -> 320 A / 650 A

Brief instructions for CD and documents overview

We appreciate that you purchased an ABB DC drive power converter and thank you for the trust you put in our products.

This brochure was put together to make sure that you continue to be satisfied with our product. It is intended to provide you with a brief overview of the product's key data, EMC notes, typical applications, start-up and trouble-shooting.

If you need more information about the product you are provided with a **CD-ROM** in addition to this brief documentation. The CD-ROM is part of this document and features the following contents:

Documentation

Our documentation is basically structured according to the following system:

Technical catalogue (3ADW000192)
as comprehensive information to engineer complete DC drive systems.

Hardware manual (3ADW000194)
as detailed information, with all important particulars about the individual components, like module dimensions, electronic boards, fans and auxiliary components. Information for mechanical and electrical installation are also included.

Firmware Manual (3ADW000193)
detailed information with all important issues about firmware and setting of parameters. The manual includes information for start-up and maintenance of the entire drive, in detailed form. This manual also includes Fault and Alarm codes and information for trouble shooting.

Service Manual (3ADW000195)
for maintenance and repair of the converters.

Applications
DCS800 DC Drive can include application software e.g. cranes, winders. In such case following procedures and assistants can be blocked or not completed. Please check for further documentation and manuals (check parameter 4.03, 83.01).

Additional **information about applications** (e.g. 12-pulse) and **technical accessories** (e.g. Hardware extension or Field bus interfaces) are handled by separate manuals. See table *DCS800 Drive manuals*.

System requirements to use the CD-ROM

- Operating system WINDOWS 2000, XP
- ADOBE READER 4.0 is sufficient (we recommend 8.0 - included on the CD-ROM)



In case the CD ROM does not start automatically please double-click on **Setup.exe**.

Further support

In addition we offer further support, since we can only be satisfied when you, as our customer, are satisfied with us and our products.

Internet
On the ABB homepage under www.abb.com/dc

you'll find abundant information for

- DC products
- service support
- the latest updates
- tools
- downloads, etc.

Please don't hesitate to visit us.

Contacts
If you require any further information, please contact your nearest **ABB Drives** office or send an email to:
DC-Drives@de.abb.com

Please give us your name, your company address and phone number. We immediately put you in contact with our specialist.

Notes on EMC

You will find further information in publication:

Technical Guide chapter: EMC Compliant Installation and Configuration for a Power Drive System

The paragraphs below describe selection of the electrical components in conformity with the EMC Guideline.

The aim of the EMC Guideline is, as the name implies, to achieve electromagnetic compatibility with other products and systems. The guideline ensures that the emissions from the product concerned are so low that they do not impair another product's interference immunity.

In the context of the EMC Guideline, two aspects must be borne in mind:

- the product's interference immunity
- the product's actual emissions

The EMC Guideline expects EMC to be taken into account when a product is being developed; however, EMC cannot be designed in, it can only be quantitatively measured.

Note on EMC conformity

The conformity procedure is the responsibility of both the power converter's supplier and the manufacturer of the machine or system concerned, in proportion to their share in expanding the electrical equipment involved.

First environment (residential area with light industry) with PDS category C2	
Not applied, since category C1 (general distribution sales channel) excluded	
Not applicable	satisfied
satisfied	

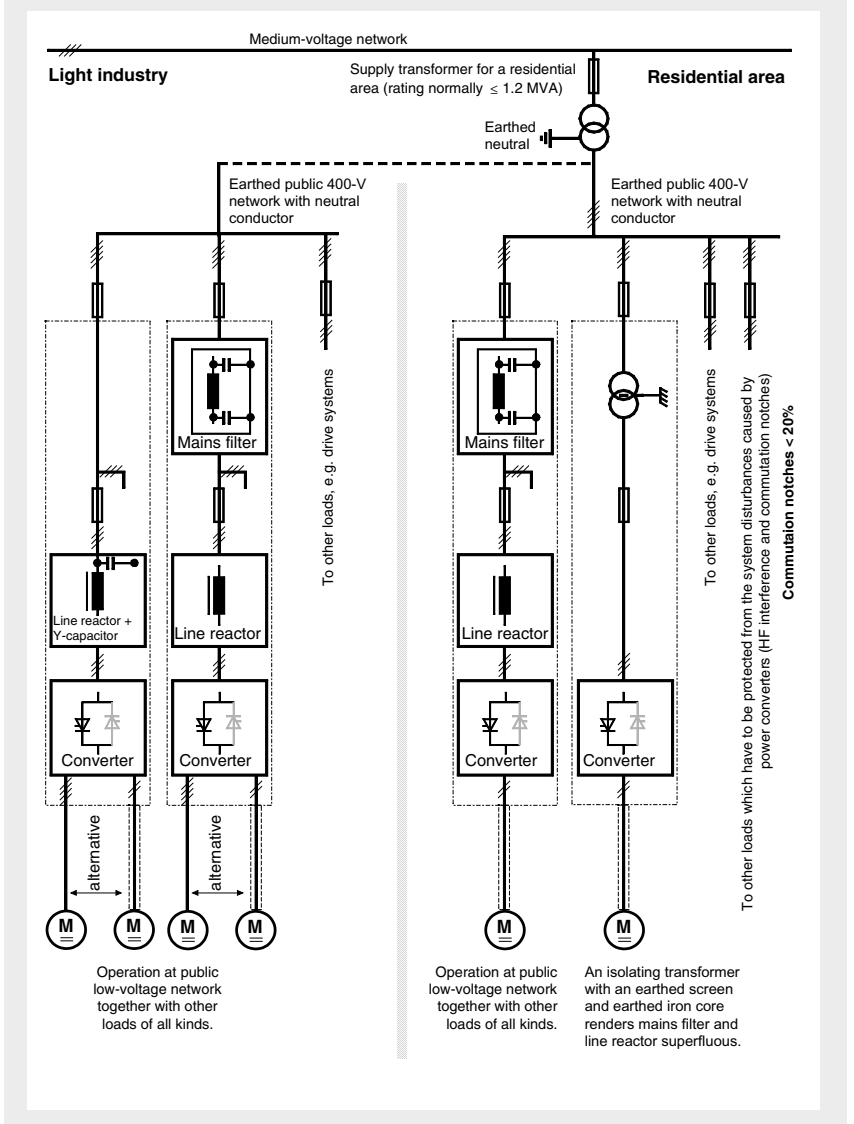
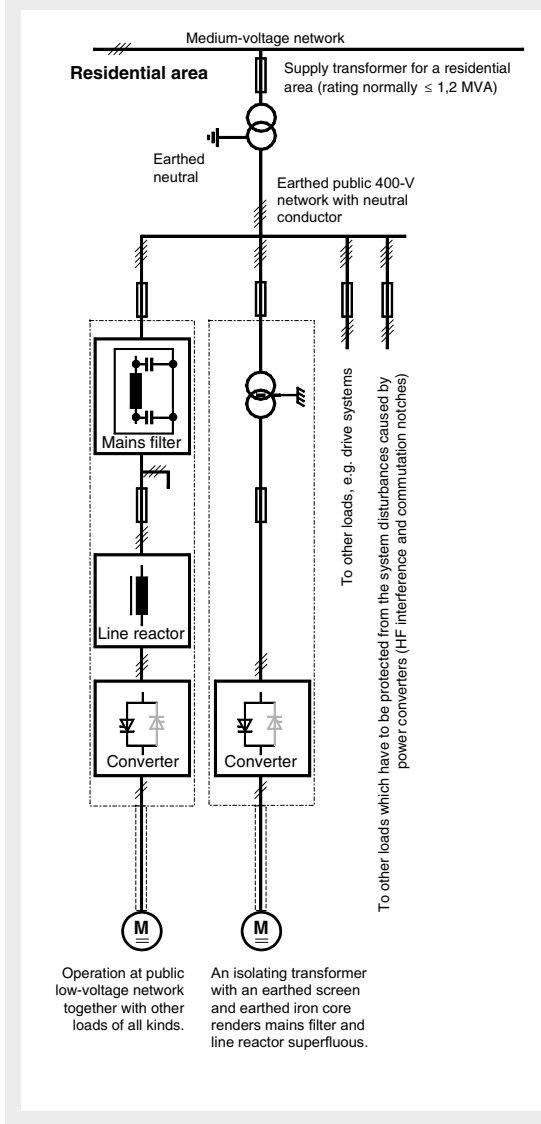

For compliance with the protection objectives of the German EMC Act (EMVG) in systems and machines, the following EMC standards must be satisfied:

Product Standard EN 61800-3

EMC standard for drive systems (PowerDrive-System), interference immunity and emissions in residential areas, enterprise zones with light industry and in industrial facilities.
This standard must be complied with in the EU for satisfying the EMC requirements for systems and machines!

For emitted interference, the following apply:

- EN 61000-6-3** Specialised basic standard for emissions in **light industry** can be satisfied with special features (mains filters, screened power cables) in the lower rating range *(EN 50081-1).
- EN 61000-6-4** Specialised basic standard for emissions in **industry** *(EN 50081-2)

For interference immunity, the following apply:

- EN 61000-6-1** Specialised basic standard for interference immunity in **residential areas** *(EN 50082-1)
- EN 61000-6-2** Specialised basic standard for interference immunity in **industry**. If this standard is satisfied, then the EN 61000-6-1 standard is automatically satisfied as well *(EN 50082-2).

* The generic standards are given in brackets

			Standards
Second environment (industry) with PDS categories C3, C4			EN 61800-3
Not applicable			EN 61000-6/3
satisfied	on customer's request	satisfied	EN 61000-6/3
satisfied			EN 61000-6-2 EN 61000-6-1

PDS category C3

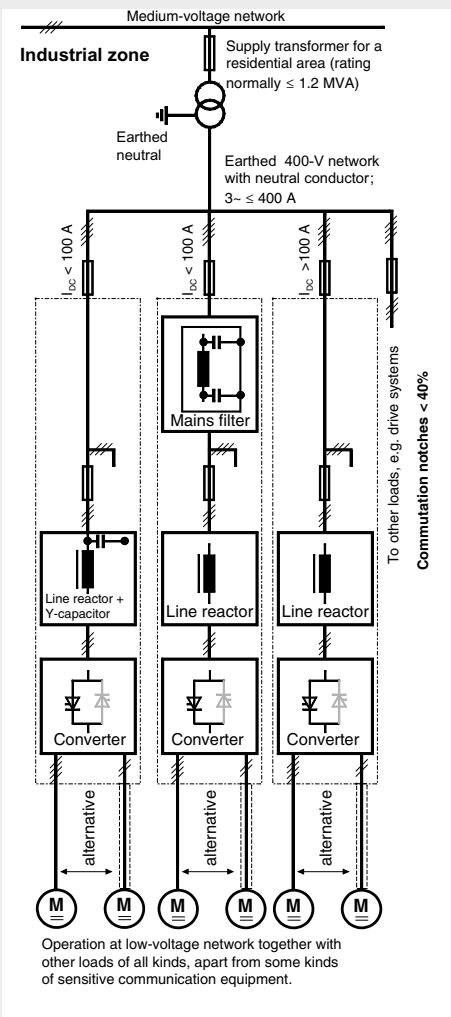

PDS category C4

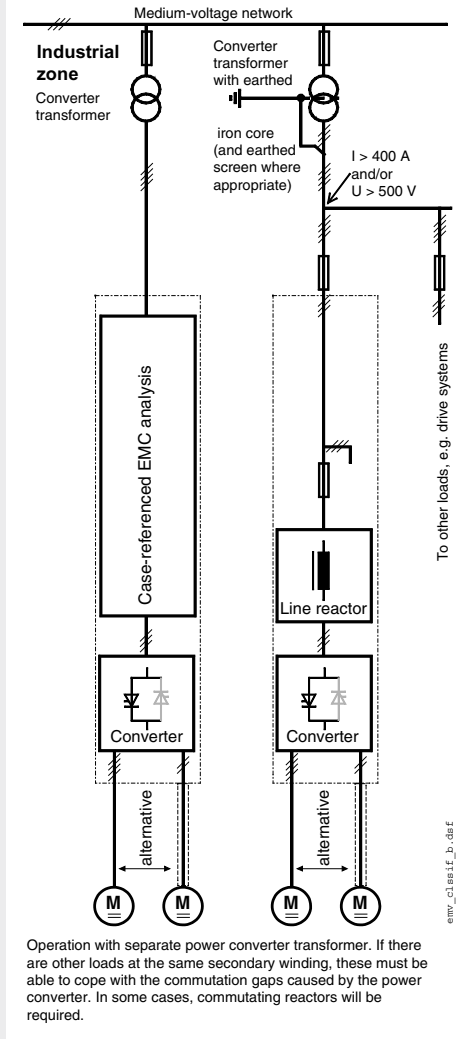

Classification

The following overview utilises the terminology and indicates the action required in accordance with Product Standard

EN 61800-3

For the DCS800 series, the limit values for emitted interference are complied with, provided the measure indicated is carried out. PDS of category C2 (formerly restricted distribution in first environment) is intended to be installed and commissioned only by a professional (person or organization with necessary skills in installing and/or commissioning PDS including their EMC aspects).

For power converters without additional components, the following warning applies:

This is a product of category C2 under IEC 61800-3:2004. In a domestic/residential environment this product may cause radio interference in which case supplementary mitigation measures may be required.

The field supply is not depicted in this overview diagram. For the field current cables, the same rules apply as for the armature-circuit cables.

Legend

	Screened cable
	Unscreened cable with restriction

Standard function assignments for the terminals

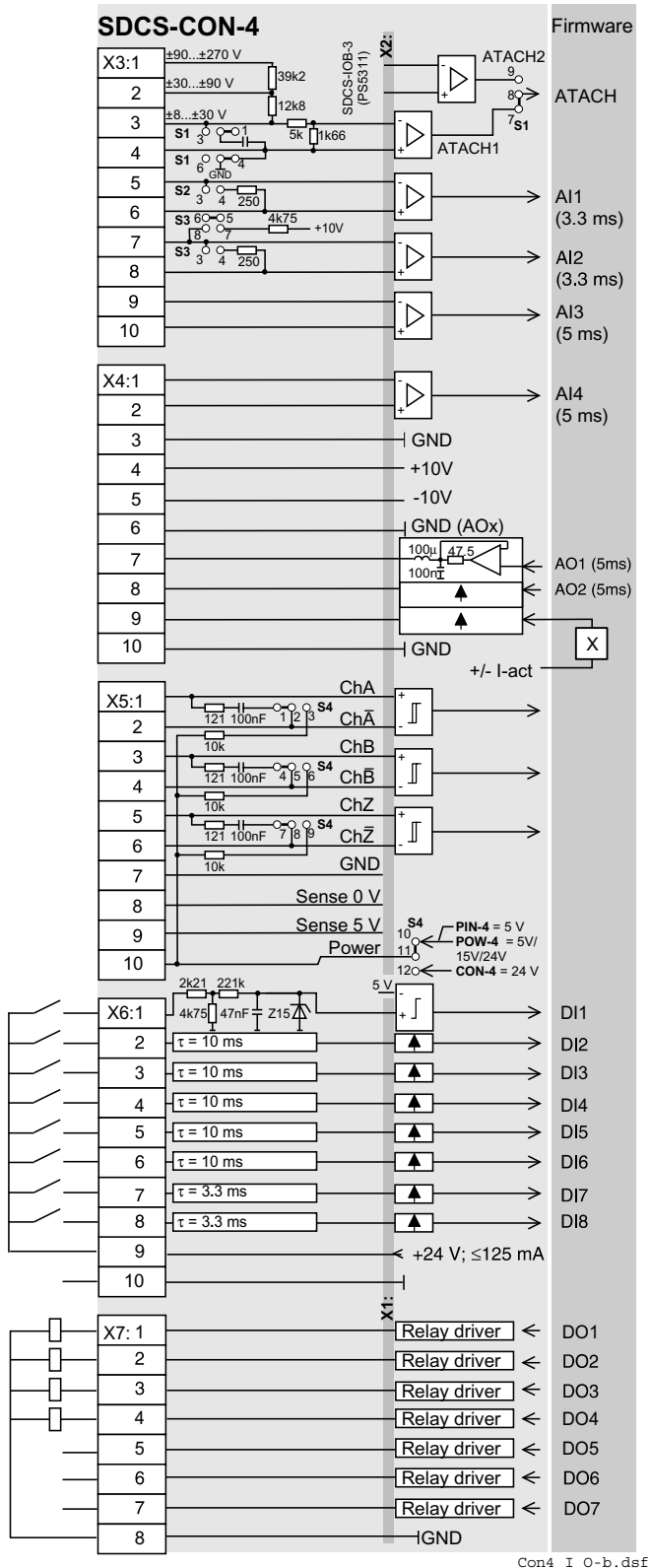

Resolution [bit]	Input/output values Hardware	Scaling by	Common mode range	Remarks
15 + sign	±90...270 V ±30...90 V ±8...30 V	① Firmware	±15 V	
15 + sign	-10...0...+10 V	Firmware	±15 V	
15 + sign	-10...0...+10 V	Firmware	±15 V	
15 + sign	-10...0...+10 V	Firmware	±15 V	
15 + sign	-10...0...+10 V	Firmware	±15V	
			Power	
	+10 V		≤ 5 mA	for ext. use e.g. refer. pot.
	-10 V		≤ 5 mA	
11 + sign	-10...0...+10 V	Firmware	≤ 5 mA	
11 + sign	-10...0...+10 V	Firmware	≤ 5 mA	
	-10...0...+10 V	Firmware+ Hardware	≤ 5 mA	8 V -> min. of 325% of [99.03] or 230% of [4.05]

Encoder supply	Remarks
	Inputs not isolated Impedance = 120 Ω, if selected max. frequency ≤ 300 kHz
5 V 24 V	≤ 250 mA ≤ 250 mA
	Sense lines for GND and supply to correct voltage drops on cable (only if 5 V encoder is in use).

Input value	Signal definition by	Remarks
0...7.3 V 7.5...50 V	Firmware	-> "0" status -> "1" status

Output value	Signal definition by	Remarks
50 * mA 22 V at no load	Firmware	Current limit for all 7 outputs = 160 mA Do not apply any reverse voltages!

* short circuit protected

① gain can be varied in 15 steps between 1 and 4 by software parameter

Connection example

Converters D1...D4 drive configuration using 'OnBoard' field exciter

Terminal selection according FACTORY macro (default)

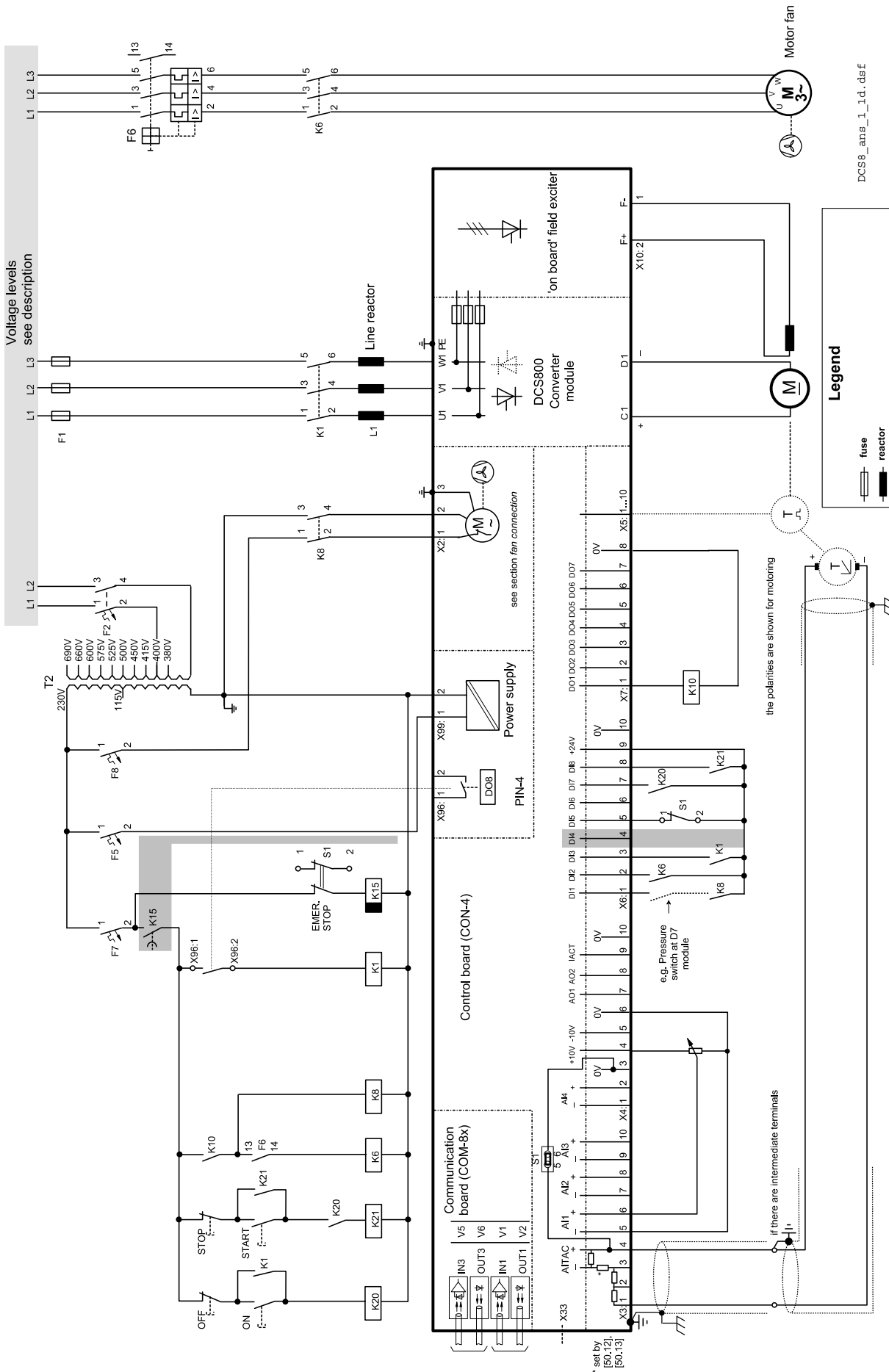

further information see the following page

START, STOP and E-STOP control

The relay logic can be split into three parts:

a: Generation of the ON/OFF and START/STOP command:

The commands represented by K20 and K21 (latching interface relay) can be e.g. generated by a PLC and transferred to the terminals of the converter either by relays, using galvanic isolation or directly via 24V signals.

These commands can be as well transferred via serial communication. Even a mixed solution can be realized by selecting different possibilities for the one or the other signal (see parameter group 11).

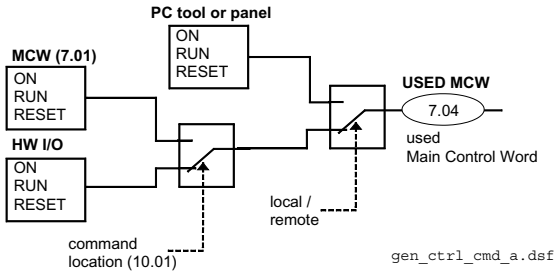

b: Generation of control and monitoring signals:

The main contactor K1 for the armature circuit is controlled by a dry contact (DO 8) located on the SDCS-PIN-4. Status of fans and fans klixon can be monitored by means of fan ack signals: MotFanAck (10.06) and ConvFanAck (10.20).

c: OFF2, OFF3 Stop function:

Beside ON/OFF and START/STOP, the drive is equipped with two additional stop functions, OFF2 and OFF3, according to Profibus standard. OFF3 is a scalable stop function (rampstop, max torque stop, dynamic braking ...) to perform stop category 1. This function should be connected to the E-STOP button without any time delay. In case of ramp stop selection, the K 15 timer relay must be set longer than the EStopRamp (22.04). For COAST selection, the drive opens the main contactor immediately.

OFF2 switches off DC current as fast as possible and prepares the drive for opening main contactor or drop down mains supply. For a normal DC motor load the time to switch OFF the DC current is below 20 ms. This function should be connected to all signals and safety functions opening the main contactor. This function is important for 4-quadrant drives. Do not open main contactor during regenerative current.

The correct sequence is

1. switch off regenerative current
2. then open the main contactor

In case of the E-STOP is hit, the information is transferred to the converter via digital input 5. In case of rampstop, or max torque selection the converter will decelerate the motor and then open main contactor.

If the drive has not finished the function within the K15 timer setting, the drive must get the command to switch OFF the current via K16. After K16 timer set has elapsed the main contactor is opened independent of the drives status.

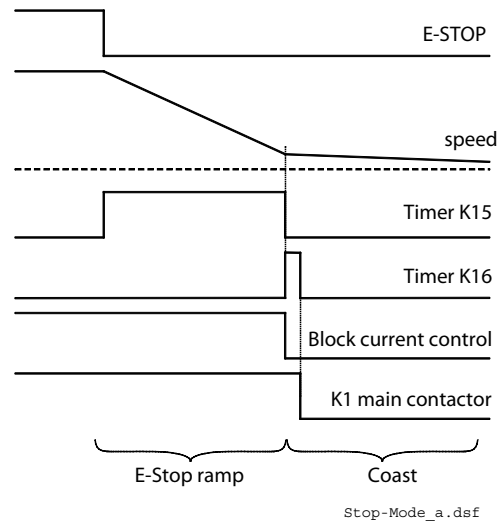
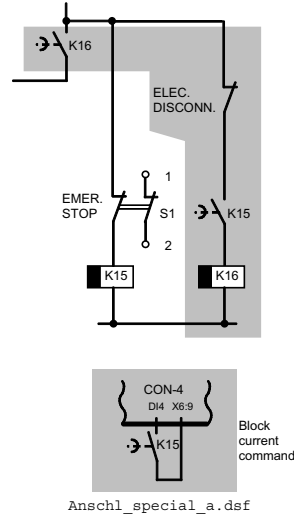

Fan power connection

Fan assignment for DCS800

Converter type	Model	Configuration	Fan voltage
DCS800-S01-0020-04/05... DCS800-S02-0025-04/05	D1	-	no fan
DCS800-S0x-0045-04/05... DCS800-S0x-0140-04/05	D1	1	115 or 230 VAC
DCS800-S0x-0180-04/05... DCS800-S0x-0260-04/05	D2	1	115 or 230 VAC
DCS800-S0x-0315-04/05... DCS800-S0x-0350-04/05	D3	1	115 or 230 VAC
DCS800-S0x-0405-04/05... DCS800-S0x-0520-04/05	D3	2	115 or 230 VAC
DCS800-S0x-0610-04/05... DCS800-S0x-0820-04/05	D4	3	230 VAC
DCS800-S0x-0610-04/05... DCS800-S0x-0820-04/05	D4 Pluscode S171	3	115 VAC
DCS800-S0x-0900-04/05... DCS800-S0x-1000-04/05	D4	3	230 VAC
DCS800-S0x-0900-04/05... DCS800-S0x-1000-04/05	D4 Pluscode S171	3	115 VAC

Fan connection for DCS800

Terminals on top of converter housing

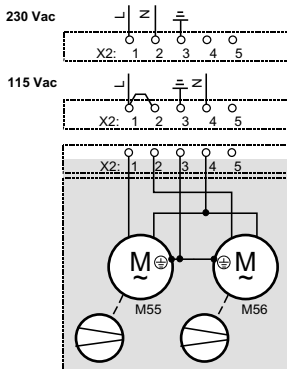

Configuration 1
D1- D3

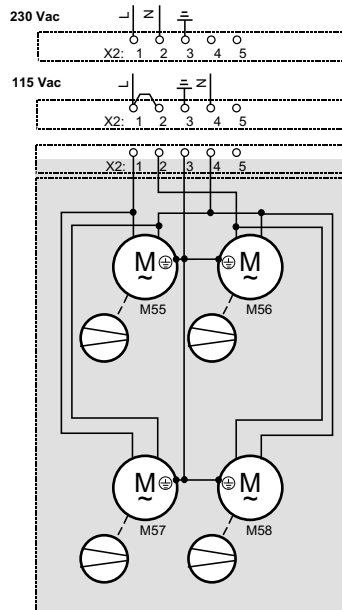

Configuration 2
D3

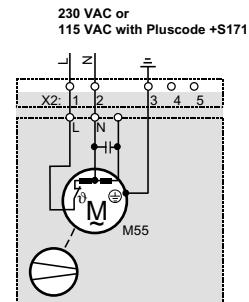

DCS8 fan conn D1-D4.dsf

Configuration 3
D4

Terminal locations on the converter

SDCS-CON-4 CONNECTOR ALLOCATION

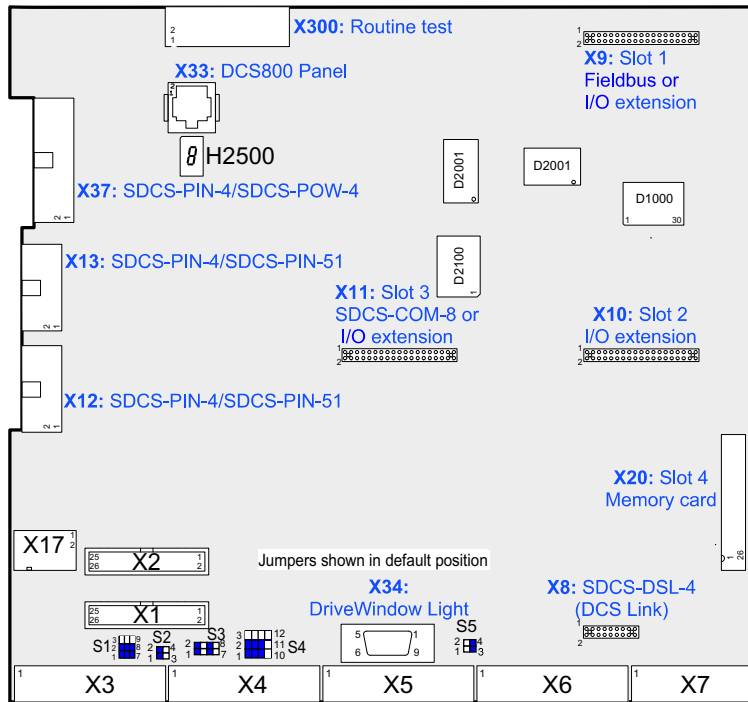

DCS800 module TERMINAL ALLOCATION

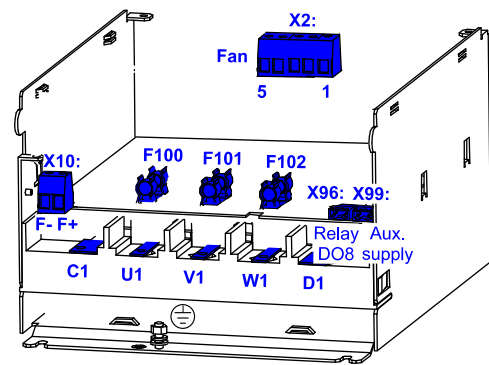

DCS800 Accessories

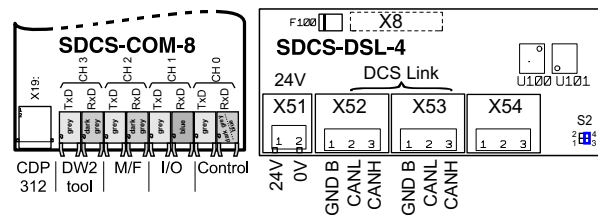

SDCS-CON-4: TERMINAL ALLOCATION

X3 Tacho and AI			X4 AI and AO			X5 Encoder			X6 DI			X7 DO		
1	2	3	4	5	6	7	8	9	10	11	12	13	14	15
90...270V	30...90V	8...30V	0V	AI1+	AI1-	AI2+	AI2-	AI3+	AI3-	AI4+	AI4-	+10V	-10V	0V
			AO1	AO2	AO3 (lact)	0V						+A	-A	+B
												-B	+Z	-Z
												GND	Sense Us	Sense Us
												DI1	DI2	DI3
												DI4	DI5	DI6
												DI7	DI8	+24
												0V	DO1	DO2
												DO3	DO4	DO5
												DO6	DO7	DO8

DCS800 terminal alloc.dsf

Macro finder

Macro name	Main Contactor	ON / OFF Start/Stop	DI function	Comment	DI5 --> ESTOP DI6 --> Reset
Standard					
	AC	Static	Jog1 --> DI1 Jog2 --> DI2 Ext Fault --> DI 3 Ext Alarm --> DI4	Hardware I/O control	x
2-wire DC cont. US					
	DC	Static	Jog1 --> DI1 Jog2 --> DI2 Ext Fault --> DI 3 Main Cont Ack --> DI4	Hardware I/O control	x
3-wire DC cont. US					
	DC	Pulse	Fix speed1 --> DI1 Ext Fault --> DI 3 Main Cont Ack --> DI4	Hardware I/O control	x
3-wire Standard					
	AC	Pulse	Fix speed1 --> DI1 Ext Fault --> DI 3 Ext Alarm --> DI4	Hardware I/O control	x
Torque limit					
	AC	Static	Jog1 --> DI1 Jog2 --> DI2 Ext Fault --> DI 3 Ext Alarm --> DI4	Hardware I/O control + Torque limit	x
Manual / Const					
	AC	Pulse	Jog1 --> DI1 Jog2 --> DI2 Direction --> DI 3 SpC - KP, KI --> DI4	Hardware I/O control select gain	x
Hand / Auto					
	AC	Static	Control select --> DI2 Reference select --> DI2 Direction select --> DI 3	Hardware I/O control or field bus control	x
Hand / Mot Pot					
	AC	Pulse	Motor pot up --> DI1 Motor pot down --> DI2 Direction select --> DI 3 Reference select --> DI4	Hardware I/O control Reference hardware or Motor potentiometer	x
Motor Pot					
	AC	Static	Direction select --> DI 1 Motor pot up --> DI2 Motor pot down --> DI3 Motor pot minimum --> DI4	Hardware I/O control Reference Motor potentiometer	x
Torque Ctrl					
	AC	Static	OFF2 (coast stop) --> DI1 Torque select --> DI2 Ext Fault --> DI 3	Hardware I/O control Speed control or Torque reference	x

Enabling a macro

Use the [DCS800Wizard] 2. Macro assistant of DriveWindow Light or

Parameter browser, either through the control panel, DriveWindow, or DriveWindow Light.

Use the following parameters:

AppIMacro (99.08) = Macro selection
AppIrestore (99.07) = YES = execute selection
MacroSel (8.10) = double check

NOTE
 Functions and inputs defined by macro can be changed later on without restrictions.

NOTE
 Macro diagrams see page 93 ...

Notes For North American Installations

1. **EMC conformity** is not usually required in North America. In most cases, the section “Notes on EMC” can be bypassed. In this manual, you will see references to DIN, EN and VDE standards. These are European standards and, generally, do not apply to North America. It is, however, the responsibility of the user to determine which standards need to be followed.

2. **If using a DC contactor**, you must connect an **auxiliary contact** to a digital input of your choice and set para. *MainContAck* accordingly. Set the following parameters:

- MainContAck* (10.21) = **DI-1** (or any input you choose for the DC cont. auxiliary contact)
- DO8BitNo* (14.16) = **10**
- MainContCtrlMode* (21.16) = **DCcontact** (3)

Set these parameters **AFTER** macros are loaded but **BEFORE** the drive is commissioned.

Digital output 8 (DO-8) must be used to turn the DC contactor on and off.

DC contactor US:

DC contactor US K1.1 is a special designed contactor with 2x NO contacts for C1 and D1 connection and 1x NC contact for connection of Dynamic Brake resistor RB.

The contactor should be controlled by signal 6.03 Bit 10. The acknowledge can be connected to parameter:

- 10.21 *MainContAck*
- 10.23 *DCBreakAck*

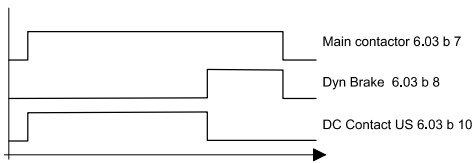

3. **If using Dynamic Braking**, the drive allows you to select the stopping method under three different situations. Parameters 21.02, 21.03 and 21.04 select the stopping method for loss of the OnOff, run command (StartStop, Jog1, Jog2, etc.), and E-Stop input, respectively.

Each can be set to:

- RampStop
- TorqueLimit
- CoastStop
- DynBraking

In order to command the drive to perform a DB stop, one or more of these parameters must be set to DynBraking. Most users will want the drive to ramp stop when OnOff or a run command (StartStop, Jog1, Jog2, etc.) input is cleared, and dynamically brake when the E-Stop input is cleared. In that case, use the following settings:

- Off1Mode (21.02) = RampStop
- StopMode (21.03) = RampStop
- E StopMode (21.04) = DynBraking

However, any case is allowed and the final decision is left to the user.

Other parameters control stops during faults.

See:

- LocalLossCtrl* (30.27) *ComLossCtrl* (30.28)
- FaultStopMode* (30.30) *SpeedFbFitMode* (30.36)

If using **EMF feedback** with dynamic braking, set:

- *DynBrakeDly* (50.11) = t
- Where: t = the time (sec) it normally takes the motor to stop during dynamic braking

Overview of the Installation and Commissioning Process

Step 1:

Check converter for damage. Contact ABB Technical Support if damage is found. In North America, call **1-800-435-7365 (1-800-HELP-365)**

This is to protect the motor and converter if a commutation fault should occur. NOTE: DC output fuses are the same type and size as AC line fuses.

Step 2:

Select supporting hardware for the converter:

Line reactor:

All thyristor-based dc converters cause notching in the AC line due to motor commutation. A properly sized line reactor will mitigate the effect on the line. Unless the converter uses a dedicated isolation transformer, each converter requires its own line reactor.

For specific recommendations for fuses, reactors, and contactors, see the DCS800 hardware manual or technical catalog.

Circuit breaker or disconnect:

$$\begin{aligned} \text{Current rating} &= I_{dc} * 0.816 * 1.25 \text{ (min)} \\ &= I_{dc} * 0.816 * 2.50 \text{ (max)} \end{aligned}$$

Where: I_{dc} = nominal DC motor current

AC or DC contactor:

A contactor is required to safely disconnect the motor from the incoming power when the converter is off. The contactor can be installed between the line and the converter (an AC contactor) or between the converter and the motor (a DC contactor). Do not use both.

Fuses:

AC Line Fuses: To properly protect the converter, semi-conductor fuses on the incoming AC power line are required in all cases.

IMPORTANT: Other equipment may be necessary depending on application and local codes.

DC Output Fuses: Fuses between the motor and the converter are required for all regenerative (4-Q) converters.

Step 3:

Mount and wire the converter and supporting hardware inside an industrial enclosure with adequate cooling (DCS800 modules have rating of NEMA type OPEN).

The following control and signal wiring is required:

- o If using an AC contactor, we recommend wiring an auxiliary contact to the digital input you have designated as *MainContAck* (10.21) or *Start/Stop* (10.16).
- o If using a DC contactor, you must wire an auxiliary contact from the contactor to the digital input you have designated as *MainContAck* (10.21).
- o Wire 115 or 230 Vac 1-phase power to terminal block 99 for converter control power.
- o Wire 1-phase power to converter for cooling fans. See table and wiring diagrams in this manual.
 - **D1 – D3 frames:** 115/230 Vac selectable. Fan terminal X2 is on top of the converter.
 - **D4 frame:** If type code includes +S171, use 115 Vac; otherwise use 230 Vac. Fan terminal X2 is on top of the converter.
- o Wire tachometer or encoder to terminal block X3 (tacho) or X5 (encoder).
- o Wire analog inputs (e.g., speed reference) and outputs (e.g., meters for motor voltage, current) to terminal block X3 and/or X4.
- o Wire high speed serial interface if needed. (Requires optional fieldbus interface board.)
- o The DCS800 allows you to choose the usage of each digital and analog input and output. The converter has factory default settings which can be changed by loading a macro, but some designations are universal. They include:
 - Digital input 5: Estop
 - Digital input 6: Fault reset
 - Digital input 7: On/Off (maintained) or On-Start (pulsed)
 - *Digital input 8: Start/Stop (maintained) or Off-Stop (pulsed)
 - Digital output 8: Main Contactor On (3 Amps max. at 115 – 230 Vac)
 *except Hand/Auto macro
- o Other signals may be required depending on your application (e.g., motor fan acknowledge input, Off2 input, fan-on output, brake output).

- o You will select the macro and/or choose the configuration for digital and analog inputs and outputs in step 2 of the commissioning process, or by updating group 10 and 14 parameters.
- o Check all wire terminations (with continuity tester) before proceeding to the next step.

Step 4:

Connect the drive system to incoming power and the motor to the converter (both field and armature) as well as accessory equipment (motor fan, thermal switch, brake, etc.).

- o See hardware manual for typical cable size and tightening torque recommendations.
- o **IMPORTANT: Be sure all safety equipment is properly sized for your application**

Step 5:

Apply control power to the converter.

- o **IMPORTANT: See section “Safety and Operating Instructions” in this manual before proceeding.**
- o Apply power to terminal block 99 and X2. The keypad should light up and show the menu screen. The converter fans should start to run (if converter has fans).

Step 6:

Commission the converter using Drive Windows Light (preferred) or the control panel.

- o **IMPORTANT: See safety alerts and general instructions in the section “Commissioning” before proceeding.**
- o Install the DCS800 PC tools on your computer. Instructions are in this manual. Use DriveWindow Light to commission your converter.
- o If no PC is available, commission your drive using the control panel as follows:
 - On the control panel, press the softkey to select MENU.
 - Using the down arrow, select ASSISTANTS. Then press ENTER.
 - Starting with “name plate data,” press SEL. Change the value with the arrow keys. Then press SAVE.
 - Repeat above with other parameters. Follow directions on the screen.

Configuring and Displaying analog and digital I/O

HINT: To see if the drive is responding to an “on” or “run” command, view signal 8.08.

Control Panel:

- o Digital Status: View signal 8.05 (DI's) or 8.06 (DO's). Display is in hexadecimal.
- o Configure digital inputs with Group 10.
- o Analog Status: View signal 5.03 (AI1) or 5.11 (AO1). Display is in Volts.
- o Configure analog speed ref. with Group 11.

DriveWindow Light:

- o Connect to the DCS800 and go on line by clicking on File, then New Online Drive.
- o Click on Wizard, at left side of the screen.
- o Click on Advanced.
- o Check the box for “I/O assistant,” then click on Next.
- o Click on “edit parameters” in the appropriate section (analog or digital inputs or outputs).

Safety and operating instructions



for drive converters DCS / DCF / DCR

(in conformity with the low-voltage directive 73/23/EEC)

1. General

In operation, drive converters, depending on their degree of protection, may have live, uninsulated, and possibly also moving or rotating parts, as well as hot surfaces.

In case of inadmissible removal of the required covers, of improper use, wrong installation or maloperation, there is the danger of serious personal injury and damage to property.

For further information, see documentation.

All operations serving transport, installation and commissioning as well as maintenance are to be carried out by skilled technical personnel (Observe IEC 364 or CENELEC HD 384 or DIN VDE 0100 and IEC 664 or DIN/VDE 0110 and national accident prevention rules!).

For the purposes of these basic safety instructions, "skilled technical personnel" means persons who are familiar with the installation, mounting, commissioning and operation of the product and have the qualifications needed for the performance of their functions.

2. Intended use

Drive converters are components designed for inclusion in electrical installations or machinery.

In case of installation in machinery, commissioning of the drive converter (i.e. the starting of normal operation) is prohibited until the machinery has been proved to conform to the provisions of the directive 89/392/EEC (Machinery Safety Directive - MSD). Account is to be taken of EN 60204.

Commissioning (i.e. the starting of normal operation) is admissible only where conformity with the EMC directive (89/336/EEC) has been established.

The drive converters meet the requirements of the low-voltage directive 73/23/EEC. They are subject to the harmonized standards of the series prEN 50178/DIN VDE 0160 in conjunction with EN 60439-1/ VDE 0660, part 500, and EN 60146/ VDE 0558.

The technical data as well as information concerning the supply conditions shall be taken from the rating plate and from the documentation and shall be strictly observed.

3. Transport, storage

The instructions for transport, storage and proper use shall be complied with.

The climatic conditions shall be in conformity with prEN 50178.

4. Installation

The installation and cooling of the appliances shall be in accordance with the specifications in the pertinent documentation.

The drive converters shall be protected against excessive strains. In particular, no components must be bent or isolating distances altered in the course of transportation or handling. No contact shall be made with electronic components and contacts.

Drive converters contain electrostatic sensitive components which are liable to damage through improper use. Electric components must not be mechanically damaged or destroyed (potential health risks).

5. Electrical connection

When working on live drive converters, the applicable national accident prevention rules (e.g. VBG 4) must be complied with. The electrical installation shall be carried out in accordance with the relevant requirements (e.g. cross-sectional areas of conductors, fusing, PE connection). For further information, see documentation.

Instructions for the installation in accordance with EMC requirements, like screening, earthing, location of filters and wiring, are contained in the drive converter documentation. They must always be complied with, also for drive converters bearing a CE marking. Observance of the limit values required by EMC law is the responsibility of the manufacturer of the installation or machine.

6. Operation

Installations which include drive converters shall be equipped with additional control and protective devices in accordance with the relevant applicable safety requirements, e.g. Act respecting technical equipment, accident prevention rules etc. Changes to the drive converters by means of the operating software are admissible.

After disconnection of the drive converter from the voltage supply, live appliance parts and power terminals must not be touched immediately because of possibly energized capacitors. In this respect, the corresponding signs and markings on the drive converter must be respected.

During operation, all covers and doors shall be kept closed.

7. Maintenance and servicing

The manufacturer's documentation shall be followed.

Keep safety instructions in a safe place!

Installing the DCS800 PC tools on Your computer

After inserting the DCS800 CD all programs and documentation necessary to work with the DCS800 will be automatically installed. This includes:

1. DriveWindow Light for parameterization, commissioning and service
2. Hitachi FDT 2.2 for firmware download
3. Installation CD of DCS800 Drive for e.g. DWL Wizard, ABB documents
4. CoDeSys for 61131 application programming

Attention:

If You do not want to install a certain program just skip it by using Cancel at the beginning of the program's wizard.

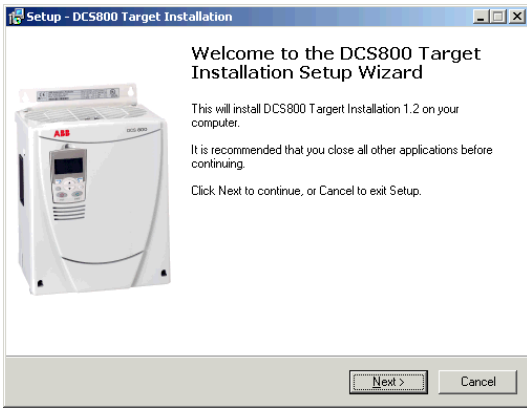

- Start DriveWindow Light PC tool
Check the communication setting of your COM port

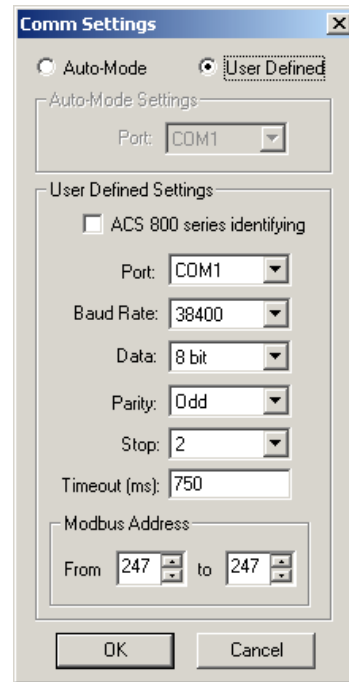

If the installation routine does not start automatically:

- Go to Start/Run and browse for setup.exe on the CD. Now start the installation by confirming with OK
- Compact installation for DriveWindow Light + Commissioning Wizard + DriveWindow Light AP is recommended

If You use USB to COM port interface or PCMCIA / COM adapters double check the active COM enabled
Start => Settings => Control Panel => System => Hardware => Device Manager

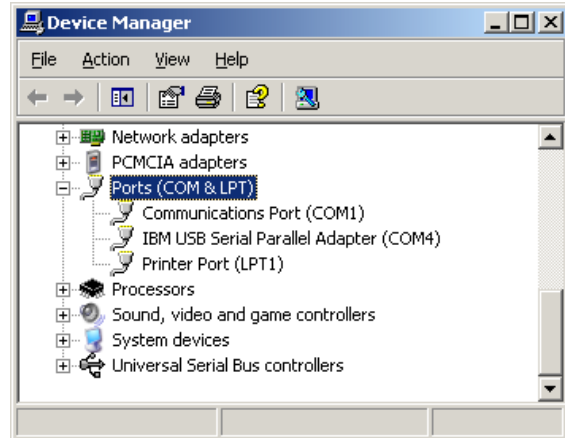
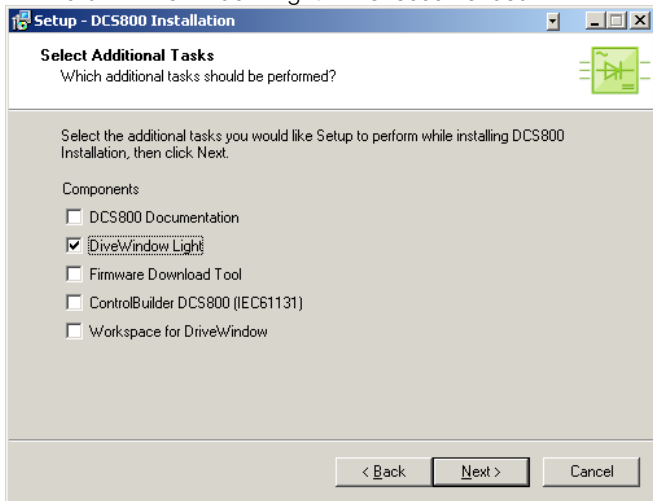

Steps to connect Drive to PC

- The documentation can be found under **C:\ABB\DCS800\Docu**
- Remove design cover from the converter module

COM address of USB interface **can** change after the next boot procedure or after disconnecting and reconnecting of the USB interface.

Note:

PCMCIA to COM Port provide a stable and faster drive interface.

Utilize DriveWindow Light or DCS800 Panel Wizard continue with chapter *Commissioning* in this manual.

For commissioning by DriveWindow find a workspace description in the DCS800 Firmware manual.



Remove the DCS800 Control Panel if present. Depress the locks to remove the cover



Connect drive (X34) to your PC COM port

Commissioning



Danger! High voltage: this symbol warns of high voltages which may result in injuries to persons and/or damage to equipment. Where appropriate, the text printed adjacent to this symbol describes how risk of this kind may be avoided.



General warning: this symbol warns of non-electrical risks and dangers which may result in serious or even fatal injuries to persons and/or damage to equipment. Where appropriate, the text printed adjacent to this symbol describes how risk of this kind may be avoided.



Warning of electrostatic discharge: this symbol warns you against electrostatic discharges which may damage to unit. Where appropriate, the text printed adjacent to this symbol describes how risk of this kind may be avoided.

NEC motor overload protection

The DCS800 provides a solid-state motor overload protection in accordance with the NEC. The overload protection (e.g. protection level in percent of full-load motor current) can be adjusted by parameters in group 31 and group 99.

The instructions can be found in chapter *Motor thermal model* of the *DCS800 Firmware manual*.

General instructions

- This short commissioning refers to *Chapter 5 Connection examples* of this publication.
- *Safety and operating instructions* - see *chapter 6* of this publication.
- Recommendations for motor and field voltages see *Technical catalogue*.
- In accordance with DIN 57 100 Part 727 / VDE 0100 Part 727, precautions must be taken to enable the drive to be shut down, e.g. in the event of danger. The unit's digital inputs or the control panel are not sufficient as the sole measure for this purpose!

Preparations

- Check unit for any damage!
- Install unit and wire it up
- Supply voltage level / Rated value correct for electronics and fan?
- Supply voltage level / Rated value correct for armature-circuit converter?
- Supply voltage level / Rated value correct for field supply?
- Wiring / cross-sections, etc. correct?
- EMERGENCY STOP functioning properly?
- COAST STOP functioning properly?

Commissioning DriveWindow Light

Start the wizard in DriveWindow Light:

For basic commissioning press the *Start* button or select a specific assistant:

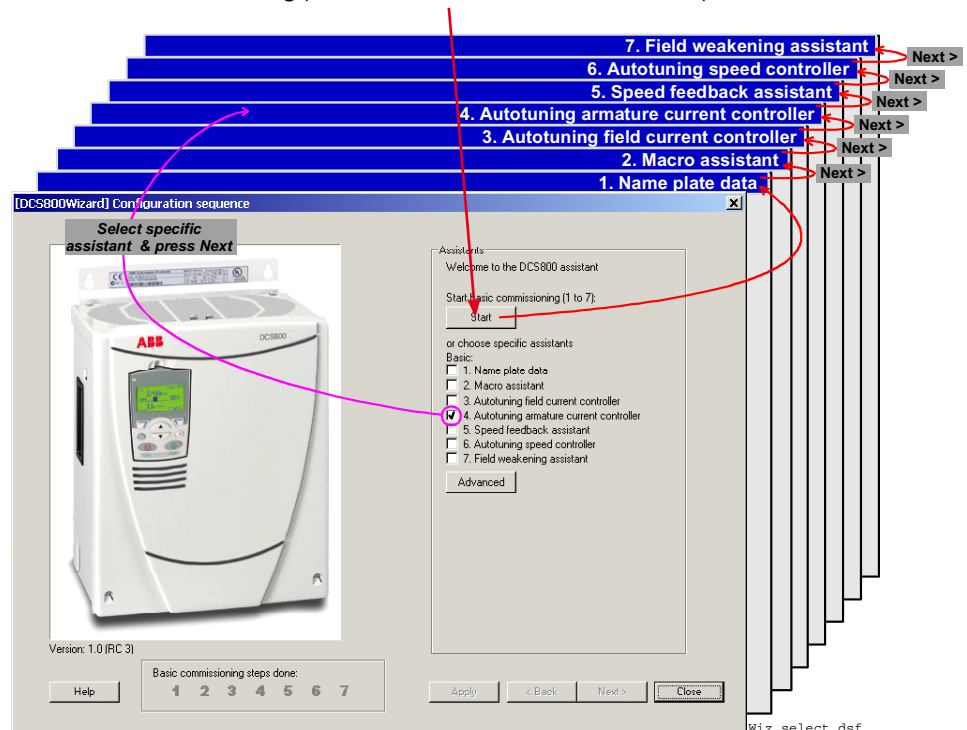
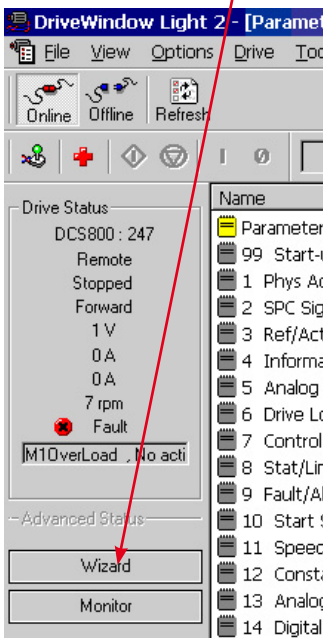

For more information about the wizard, parameters faults and alarms press the *Help* button!

DCS800 Control Panel

The following table summarizes the button functions and displays of the DCS800 Control Panel (DCS CP).

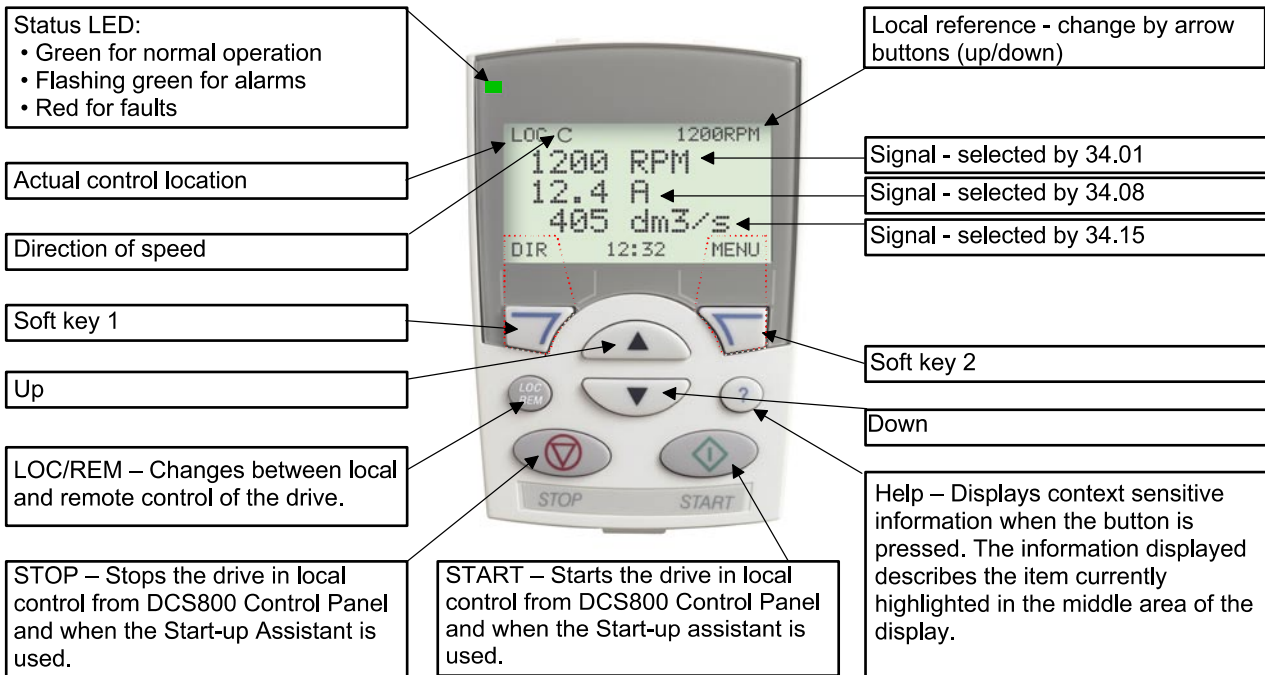

DCS800 QG pan ov_a.ds f

With USISel (16.09) it is possible to limit the amount of displayed parameters!

General display features

Following modes are available in the MAIN MENU:

1. Parameters mode
2. Start-up assistants mode
 - a. Name plate data
 - b. Macro assistant
 - c. Autotuning field current controller
 - d. Autotuning armature current controller
 - e. Speed feedback assistant (Tacho fine tuning not available)
 - f. Autotuning speed controller
 - g. Field weakening assistant (only used when maximum speed is higher than base speed)
3. Macros mode (currently not used)
4. Changed parameters mode (compare to default and display changed parameters)
5. Fault logger mode (Display fault history)
6. Clock set mode
7. Parameter backup mode
 - copy active parameter set from the drive into the DCS800 Control Panel (only in local mode)
 - copy parameter set from DCS800 Control Panel into the drive (only in local mode)
8. I/O settings mode (currently not used)

Parameters entered by assistant

99.02	Motor 1 nominal Voltage
99.03	Motor 1 nominal current
99.04	Motor 1 base speed
20.01	Motor 1 minimum speed
20.02	Motor 1 maximum speed
99.11	Motor 1 nominal field current
30.09	Armature over current level
30.16	Motor 1 over speed
99.10	Nominal mains voltage
99.12	Motor 1 used fex type
20.05	Torque maximum
20.06	Torque minimum
20.12	Motor 1 current limit bridge 1
20.13	Motor 1 current limit bridge 2
50.04	Motor 1 encoder pulse number, if selected
50.02	Motor 1 encoder measured mode, if selected
50.13	Motor 1 tacho volt, only DWL
50.12	Motor 1 tacho adapt, only DWL
20.03	Zero speed limit
22.01	Acceleration time 1
22.02	Deceleration time 1
30.12	Motor 1 field minimum trip
44.01	Field control mode



Standard Features

- kompakt
- Höchste Leistungsfähigkeit
- Einfachste Bedienung
- Komfortable Assistenten, z. B. zur Inbetriebnahme oder Fehlersuche
- Skalierbar für alle Anwendungen
- Frei programmierbar dank eingebauter IEC61131-SPS

DCS800 Gleichstromantriebe

Technische Daten DCS800

Nennanschlusssp. 230 bis 1.200 V
+/-10%, 3~

Frequenz 50 bis 60 Hz +/-5 Hz

Elektronikspg. 115 bis 230 V
-15% / +10%, 1~

DC Ausgangsstrom 20 bis 5.200 A

Überlastbarkeit 200%

Umgebungsgrenzwerte

Umgebungstemp. 0° bis +40° C
40° bis 55° C
Stromreduktion

Lagertemperatur -40° bis +55° C

Transporttemp. -40° bis +70° C

Relative Luftfeuchtigkeit 5 bis 95%, nicht kondensierend
max. 50% zw. 0° und 5° C

Verschmutzungsgrad Klasse 2

Schutzgrad IP 00

Betriebshöhe bis 1.000 m üNN
Nennstrom
Über 1.000 m üNN
Stromreduktion

Ein-/ Ausgänge

Digitale Eingänge 8 Standard, bis 14 optional

Digitale Ausgänge 8 Standard, bis 12 optional

Analoge Eingänge 4 Standard +/-10 V; 0/2...10 V bis 8 optional +/-2 0mA; 0/4...20 mA

Analoge Ausgänge 3 Standard (1x I_{ist}) +/-10 V; 0/2...10 V bis 7 optional -20 mA; 0/4...20 mA

PC-Tools

DriveWindow Light kostenlos mit jedem Antrieb, Standard RS232 Verbindung

DriveWindow Echtzeit optische Verbindung

ControlBuilder DCS800 IEC61131 Programmierung

DriveSize Antriebs- und Motorauslegung

Wartung / Diagnose

Fernwartung von jedem Internet-PC aus

- mit Internet Browser / Internet Explorer
- oder mit DriveWindow Vollzugriff via OPC

Zulassungen

Adaptive Programmierung

fertige antriebspezifische Blöcke, darunter

- Freier Prozessregler (PI-Regler)
- Ein/Ausgänge

Mit Bedien-Panel oder PC-Tool, ohne zusätzliche Hardware

Drehzahlrückführung

EMK
Analoger Tachometer
Inkrementalgeber
Zweiter Inkrementalgeber möglich (RTAC)

Kommunikation

Verfügbare serielle Schnittstellen

- Ethernet
- Profibus
- CANopen
- DeviceNet
- ControlNet
- DDCS
- Modbus
- CS31
- AF100
- Selma2

Industrial IT® enabled

DCSLink Peer-to-Peer

- bis 800 kBAud, < 2,5 ms
- Master-Follower
- Anker-Feldstromrichter
- frei definierbare Daten

Hochstromlösungen

- 12-puls bis 20.000 A, seriell und parallel
- Hart parallel und sequenziell
- bis 1.500 V

Schutzfunktionen

Tachosignalüberwachung • Temperatur • Überlast • Überdrehzahl • Motor blockiert • Motorüberstrom • Motorüberspannung • Feldüberstrom • Feldüberspannung • Mindestfeldstrom • Drehzahl Null • Ankerstromwelligkeit • Netz Über- und Unterspannung

Integrierte IEC 61131-SPS

- Offenes Programmierool ControlBuilder DCS800
- Unterstützung aller fünf IEC-Sprachen
- Antriebspezifische Funktionsblöcke
- Speicherung in Memory Karte
- Online Debugging und Forcing

Nennstrom, Abmessungen

Baugröße	2-Q Dauerstrom DCS800-01 I _{DC} [A]	4-Q Dauerstrom DCS800-02 I _{DC} [A]	Versorgungsspannung [V _{AC}]							maximaler Feldstrom intern [A _{DC}]	Abmessungen	
			400	525	600	690	800	990	1200		h x b x t [mm]	h x w x d [inch]
D1	20	25	●	●					6	370 x 270 x 200	14,56 x 10,65 x 7,90	
	45	50	●	●								
	65	75	●	●								
	90	100	●	●								
	125	140	●	●								
D2	180	200	●	●				15	370 x 270 x 270	14,56 x 10,65 x 10,65		
	230	260	●	●								
D3	315	350	●	●	● ³⁾			20	459 x 270 x 310	18,07 x 10,65 x 12,25		
	405	450	●	●								
	470	520	●	●								
D4	610	680	●	●	● ³⁾			25	644 x 270 x 345	25,35 x 10,65 x 13,60		
	740	820	●	●								
	900	1000	●	●								
D5	900	900	●	●	●	●		25	1050 x 510 x 410	41,35 x 20,10 x 16,15		
	1200	1200	●	●								
	1500	1500	●	●	●	●						
	2000	2000	●	●	● ¹⁾	● ¹⁾						
D6	1900	1900		●	●	●	●	extern. Feld 35A, 1~/3~ 50/60A, 1~/520A, 3~	1750 x 460 x 410	68,90 x 18,15 x 16,15		
	2050	2050		●	●	●						
	2500	2500	●	●	●	●						
	3000	3000	●	●	●	●						
D7	2050	2050		●	●	●	●	extern. Feld 35A, 1~/3~ 50/60A, 1~/520A, 3~	1750 x 760 x 570	68,90 x 29,95 x 22,45		
	2600	2600		●	●	●	● ²⁾					
	3300	3300	●	●	●	●	● ²⁾					
	4000	4000	●	●	●	●						
	4800	4800	●	●	●	●						
	5200	5200	●	●	●	●						

●¹⁾ nur als 2-Q Antrieb verfügbar

●²⁾ auf Anfrage

●³⁾ 600V

2-Q -> 290 A / 590 A
4-Q -> 320 A / 650 A

Kurzanweisung CD und Dokumentationsübersicht

Wir freuen uns, dass Sie einen ABB DC-Stromrichter erworben haben und bedanken uns für das Vertrauen, welches Sie unseren Produkten entgegengebracht haben.

Damit Sie auch weiterhin mit unserem Produkt zufrieden sind, haben wir diese Broschüre für Sie zusammengestellt. Sie soll hauptsächlich dazu dienen, Ihnen einen kurzen Überblick über das Produkt, EMV Hinweise, typische Anwendungen, Inbetriebnahme und Fehlersuche zu verschaffen.

Benötigen Sie weitere Informationen zum Produkt, wurde zusätzlich mit dieser Broschüre eine **CD-ROM** geliefert. Die CD-ROM ist Teil dieser Broschüre und hat folgende Bestandteile:

Dokumentation

Unsere Dokumentation ist folgendermaßen aufgebaut:

Technischer Katalog (3ADW000192)

als umfassende Information zur Planung kompletter DC-Stromrichter.

Hardware Handbuch (3ADW000194)

als Detailinformation mit allen wichtigen Angaben zu den Einzelkomponenten, wie z.B. Modulabmaße, Elektronikarten, Lüfter und Zusatzkomponenten. Informationen über die mechanische- und elektrisch Installation sind auch enthalten.

Firmware Handbuch (3ADW000193)

Detailinformation mit allen wichtigen Angaben zur Firmware und Einstellungen der Parameter. Dieses Handbuch enthält mit allen notwendigen Informationen zur Inbetriebnahme. Außerdem sind sowohl alle Fehler- und Alarmmeldungen aufgelistet als auch Informationen zur Fehlersuche.

Service Manual (3ADW000195)

für die Wartung und Reparatur der Stromrichter.

Applikationen

Der DCS800 DC-Stromrichter kann auch Applikationsprogramme enthalten z.B. für Kräne und Wickler. In solchen Fällen ist es möglich, daß die folgenden Anweisungen oder diverse Assistenten entweder gesperrt sind oder nicht beendet werden können. Bitte mit Hilfe weiterführender Dokumentation überprüfen (siehe auch Parameter 4.03 und 83.01).

Weitere **Informationen über Applikationen** (z.B. 12-Puls) und technisches Zubehör (z.B. Hardwareerweiterungen oder Feldbusadapter) werden in separaten Handbüchern behandelt. Siehe *Tabelle DCS800 Antrieb Handbücher*.

Systemvoraussetzungen für die Nutzung der CD ROM

- Betriebssystem WINDOWS 2000, XP
- ADOBE READER 4.0 ist ausreichend (empfohlen wird 8.0 - auf der CD ROM enthalten)



In case the CD ROM does not start automatically please double-click on **Setup.exe**.

Weitere Unterstützung

Wir bieten Ihnen darüber hinaus weitere Unterstützung an, denn nur wenn Sie als Kunde mit uns und unseren Produkten zufrieden sind, können auch wir zufrieden sein.

Internet

Auf der ABB Homepage unter

www.abb.com/dc

finden Sie viele Informationen zu

- DC Produkten
- Service
- neueste Updates
- Anwendersoftware
- Downloads etc.

Bitte zögern Sie nicht uns dort zu besuchen.

Kontakte

Benötigen Sie weitere Informationen, sprechen Sie bitte Ihr nächstgelegenes **ABB Drives Büro** an oder schreiben Sie eine E-Mail an:

DC-Drives@de.abb.com

Geben Sie bitte Ihren Namen, Ihre Firmenadresse und Telefonnummer an und wir werden Ihnen umgehend den für Sie zuständigen Ansprechpartner mitteilen.

EMV Filter

Weitere Informationen

hierzu siehe:

*Technical Guide Kapitel:
EMC compliant Installation
and Configuration for a
Power Drive System*

Nachfolgend wird die Auswahl der elektrischen Komponenten entsprechend der EMV-Richtlinie beschrieben.

Ziel der EMV-Richtlinie ist es, wie der Name sagt, eine elektromagnetische Verträglichkeit mit anderen Produkten und Systemen herzustellen. Die Richtlinie stellt sicher, dass die von dem Produkt abgestrahlten Emissionen so gering sind, dass sie die Störfestigkeit eines anderen Produkts nicht beeinträchtigen. Im Zusammenhang mit der EMV-Richtlinie sind zwei Aspekte zu berücksichtigen:

- die Störfestigkeit des Produkts
- die tatsächlichen Emissionen des Produkts

Die EMV-Richtlinie verlangt, dass die EMV bereits bei der Produktentwicklung berücksichtigt werden muss; jedoch kann die EMV nicht mit eingeplant werden, sie kann nur quantitativ gemessen werden.

Hinweis zur EMV

Das richtige Vorgehen liegt sowohl in der Verantwortung der Stromrichterlieferanten wie auch des Maschinen- oder Anlagenbauers entsprechend ihrem Anteil an den elektrischen Einrichtungen.

Erste Umgebung (Wohngebiete mit Leichtindustrie) mit PDS Kategorie C2

Nicht möglich, da Kategorie C1 (**Vertriebskanäle für Produkte mit allgemeiner Erhältlichkeit**) entfällt

Entfällt

Erfüllt

Erfüllt

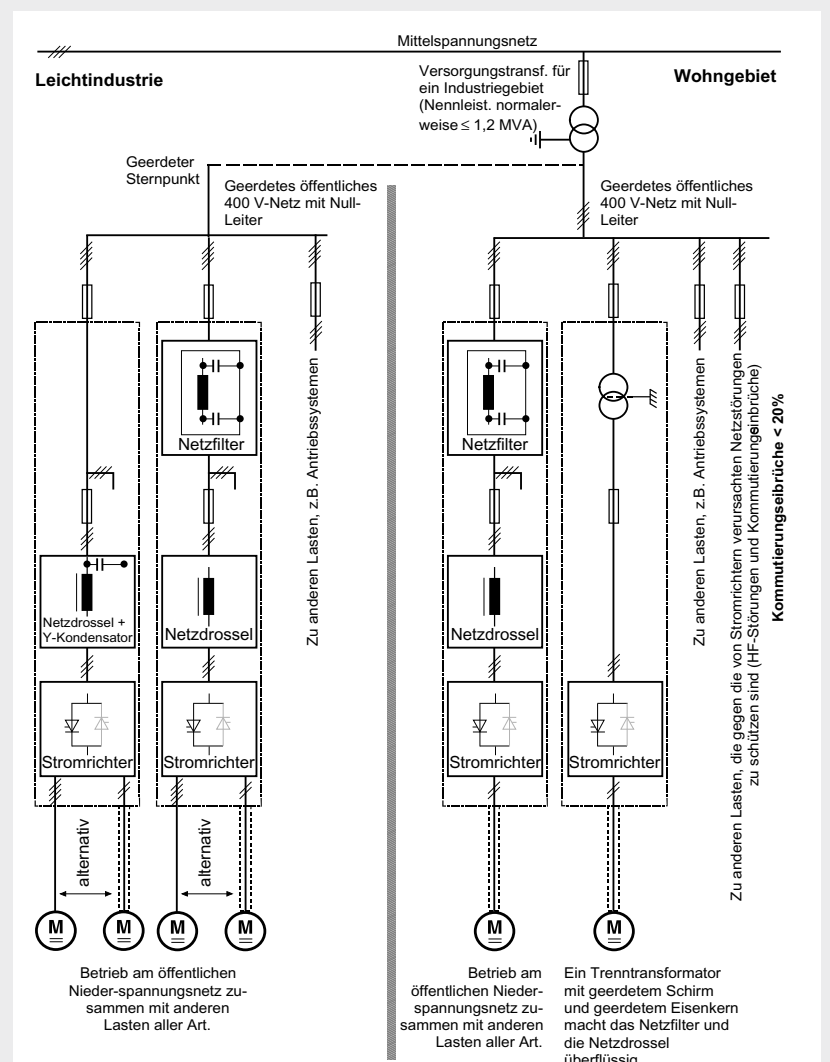
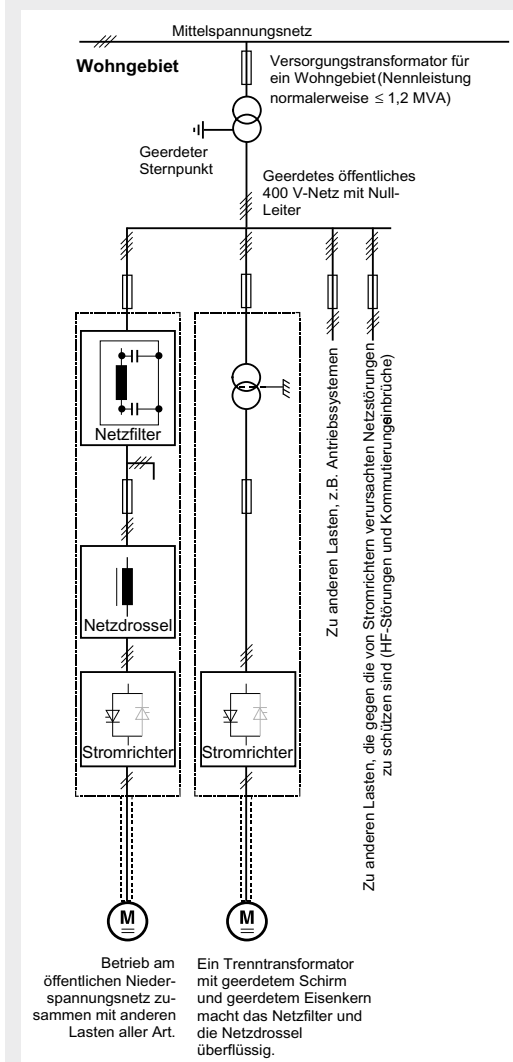

Um bei Maschinen und Anlagen die Schutzvorgaben des deutschen EMV-Gesetzes (EMVG) erfüllen zu können, müssen folgende EMV-Normen eingehalten werden:

Produktnorm EN 61800-3

EMV-Norm für Stromrichtersysteme (Power Drive System), Störfestigkeit und Abstrahlungen in Wohn-, Gewerbegebieten mit Leichtindustrie und Industrieanlagen. Diese Norm innerhalb der EU zur Einhaltung der EMV-Anforderungen für Maschinen und Anlagen erfüllt werden!

Normen für Störabstrahlungen:

EN 61000-6-3 Die spezielle Basisnorm für Abstrahlungen in der **Leichtindustrie** kann mit speziellen Einrichtungen (Netzfiltern, geschirmten Kabeln) im unteren Leistungsbereich erfüllt werden *(EN 50081-1).

EN 61000-6-4 Spezielle Basisnorm für Abstrahlungen in der **Industrie** *(EN 50081-2)

Normen für Störfestigkeit::

EN 61000-6-1 Spezielle Basisnorm für Störfestigkeit in **Wohngebieten** *(EN 50082-1)

EN 61000-6-2 Spezielle Basisnorm für Störfestigkeit in **Industrieanlagen**. Wenn diese Norm erfüllt ist, ist auch automatisch die Norm EN 61000-6-1 erfüllt *(EN 50082-2).

* Die alten Normen sind in Klammern angegeben.

			Standards
Zweite Umgebung (Industrie) mit den PDS-Kategorien C3, C4			EN 61800-3
Entfällt			EN 61000-6/3
Erfüllt	Auf Kundenwunsch	Erfüllt	EN 61000-6/3
Erfüllt			EN 61000-6-2 EN 61000-6-1

PDS Kategorie C3

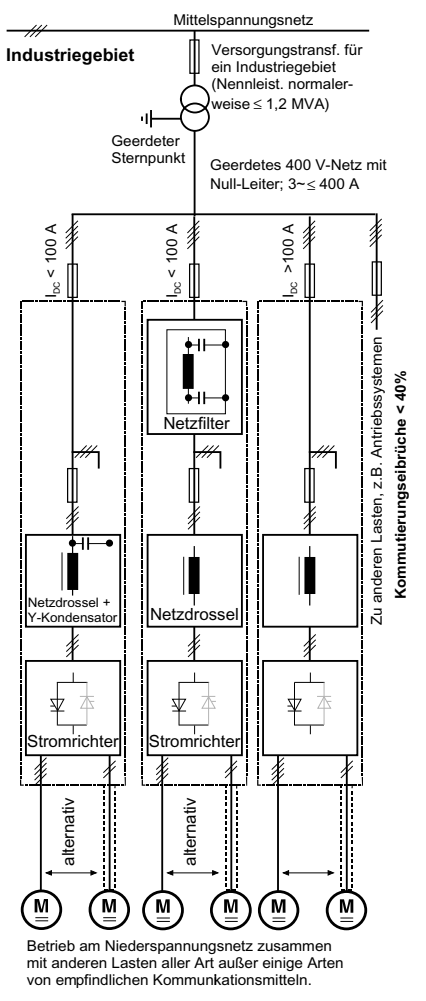

PDS Kategorie C4

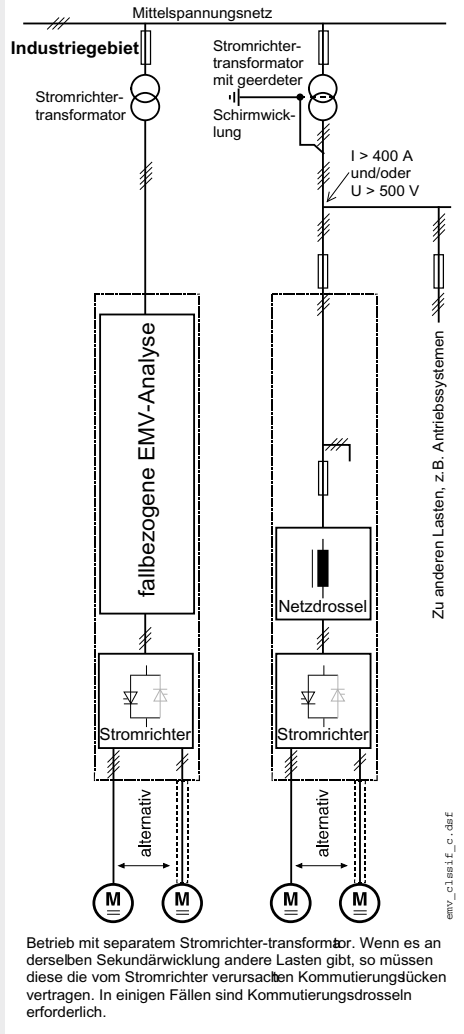

Klassifizierung

In der folgenden Übersicht werden die Maßnahmen dargestellt, die zur Einhaltung der Produktnorm erforderlich sind.

EN 61800-3

Bei der DCS800-Serie werden die Grenzwerte für Störabstrahlungen eingehalten, wenn die angegebenen Maßnahmen durchgeführt werden. PDS der Kategorie C2 (früher eingeschränkte Erhältlichkeit in der Ersten Umgebung) ist ausschließlich für die Installation und Inbetriebnahme durch Fachpersonal (Person oder Organisation mit dem erforderlichen Sachverstand bzw. Inbetriebnahme des PDS einschließlich EMVmaßnahmen) vorgesehen.

Bei Stromrichtern ohne Zusatzkomponenten sind folgende Warnhinweise zu beachten:

Es handelt sich um ein Produkt der Kategorie C2 gemäß IEC 61800-3:2004. In Wohngebieten kann dieses Produkt Funkstörungen verursachen. In diesem Fall sind zusätzliche Maßnahmen erforderlich.

Die Feldversorgung wird in dieser Übersicht nicht dargestellt. Für Feldstromkabel gelten dieselben Regeln wie für die Ankerstromkreise.

Legende

	abgeschirmtes Kabel
	ungeschirmtes Kabel mit Einschränkung

Digitaler und analoger E/A-Anschluss von SDCS-CON-4

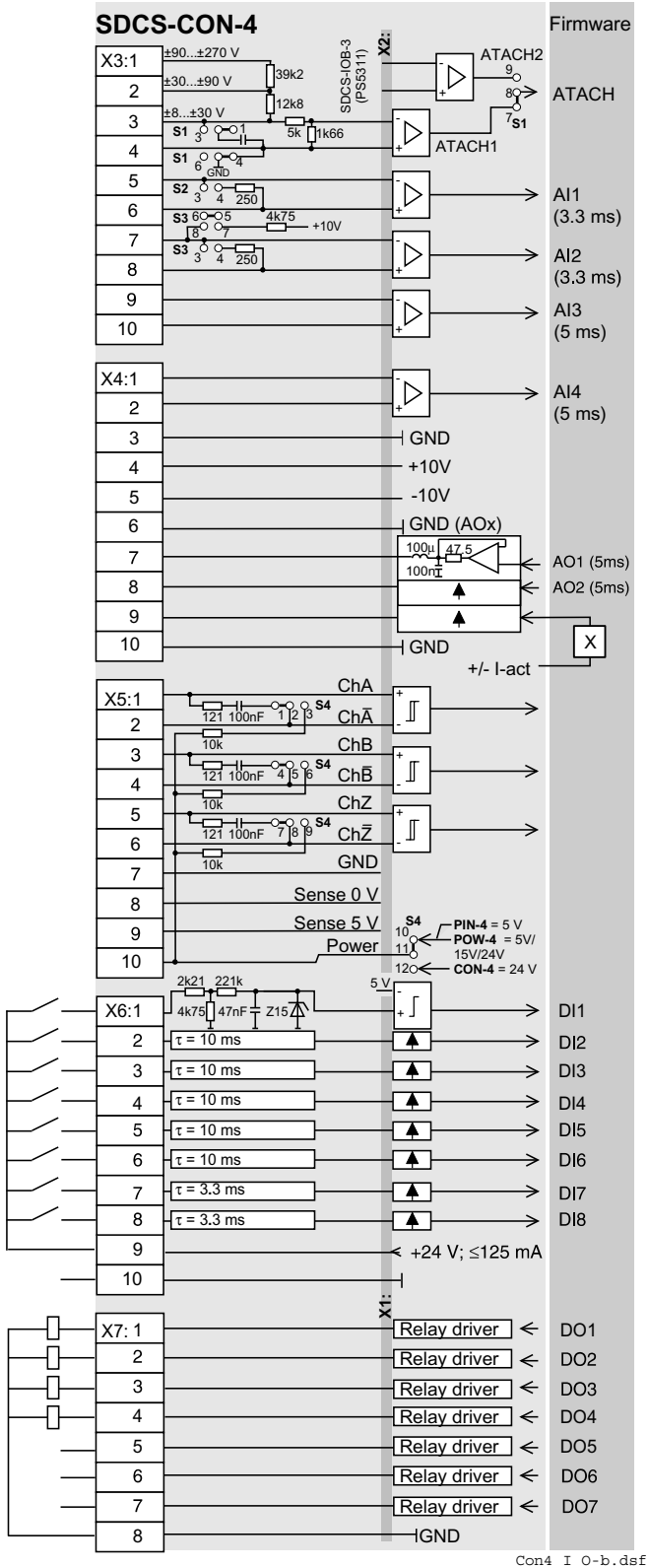

Con4_I_O-b.dsf

Auflösung [bit]	Ein-/Ausgangswerte Hardware	Skalierung durch	Gleich-takt-bereiche	Anmerkungen
15 + Vorzeichen	±90...±270 V ±30...±90 V ±8...±30 V	① Firmware	±15 V	
15 + Vorzeichen	-10...0...+10 V	Firmware	±15 V	
15 + Vorzeichen	-10...0...+10 V	Firmware	±15 V	
15 + Vorzeichen	-10...0...+10 V	Firmware	±15 V	
15 + Vorzeichen	-10...0...+10 V	Firmware	±15V	

				Spannung	
	+10 V		≤ 5 mA		für ext. Verwendung z.B. Poti
	-10 V		≤ 5 mA		
11 + Vorzeichen	-10...0...+10 V	Firmware	≤ 5 mA		
11 + Vorzeichen	-10...0...+10 V	Firmware	≤ 5 mA		
	-10...0...+10 V	Firmware+ Hardware	≤ 5 mA		8 V -> min von 325% von [99.03], oder 230% von [4.05]

Impulsgebersversorgung	Anmerkungen	
	Eingänge nicht potentialgetrennt Impedanz = 120 Ω, falls gewählt max. Frequenz ≤ 300 kHz	
5 V 24 V	≤ 250 mA ≤ 250 mA	Leitungen für GND und Einspeisung zur Korrektur von Spannungsschwankungen (nur bei Verwendung eines 5 V Impulsgebers).

Eingangswert	Signaldefinition durch	Anmerkungen
0...7,3 V 7,5...50 V	Firmware	-> "0" Status -> "1" Status

Ausgangswert	Signaldefinition durch	Anmerkungen
50 * mA 22 V bei Null-Last	Firmware	Stromgrenzwert für alle 7 Ausgänge = 160 mA Keine Gegenspannungen verwenden!

* kurzschlussfest

① Verstärkung kann in 15 Schritten zwischen 1 und 4 über Softwareparameter geändert werden

Anschlussbeispiel

Stromrichter D1...D4 mit 'On Board' Felderregler

Die Verdrahtung des Stromrichters entspricht dem Macro FACTORY (default)

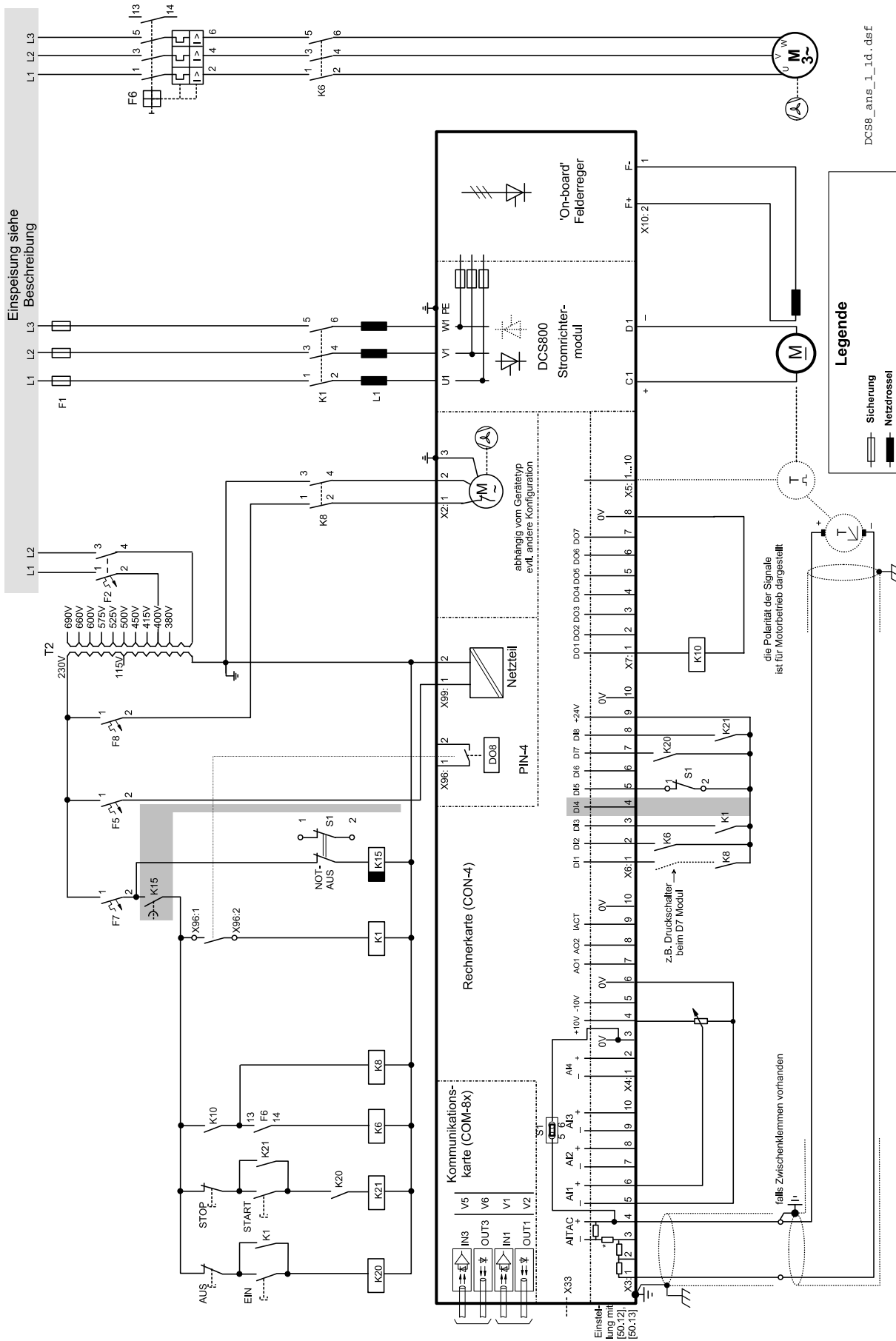

further information see the following page

START-, STOPP- und NOT-AUS-Steuerung

Die Relaislogik kann in drei Teile untergliedert werden:

a: Ausgabe des EIN/AUS- und START/STOPP-Befehls:

Die mit K20 und K21 dargestellten Befehle (Steuerung über Hardware-Klemmen) können z.B. mit einer SPS erzeugt werden und entweder über Relais mit galvanischer Trennung oder direkt über 24V-Signale an die Anschlüsse des Stromrichters übertragen werden. Festverdrahtete Signale sind nicht notwendig.

Diese Befehle können auch über die serielle Kommunikation übertragen werden. Eine kombinierte Lösung ist ebenfalls möglich, indem für das eine oder andere Signal unterschiedliche Optionen gewählt werden (siehe Parametergruppe 11).

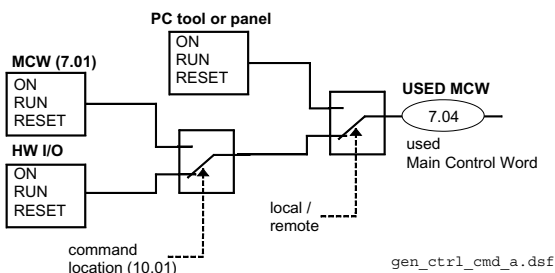

b: Ausgabe von Steuer- und Überwachungssignalen:

Das Hauptschütz K1 für den Ankerstromkreis wird über einen Relaisausgang (DO 8) auf der SDCSPIN- 4 gesteuert, der Status der Lüfter kann über die Lüfterrückmeldesignale überwacht werden: Mot- FanAck (10.06) und ConvFanAck (10.20).

c: OFF2, OFF3 Stoppfunktion:

Neben EIN/AUS und START/STOPP verfügt der Stromrichter auch über zwei zusätzliche Stoppfunktionen OFF2 und OFF3 gemäß Profibus-Standard. OFF3 ist eine skalierbare Stoppfunktion (Rampenstopp, Stopp max. Drehmoment, dynamische Bremsung...) für Stoppkategorie 1. Diese Funktion muss unverzüglich auf den NOT-AUS- (Not-Halt-) Taster angeschlossen werden. Bei Stopp über Rampe muss das Zeitrelais K 15 auf eine längere Zeit als EStopRamp (22.04) eingestellt werden. Bei COAST öffnet der Stromrichter das Hauptschütz sofort.

OFF2 schaltet den DC-Strom so schnell wie möglich ab und bereitet den Stromrichter auf das Öffnen des Hauptschützes oder den Abfall der Netzspannung vor. Bei Normallast eines DC-Motors beträgt die Zeit zum Abschalten des DC-Stroms weniger als 20 ms. Diese Funktion sollte für alle Signale und Schutzfunktionen zum Öffnen des Hauptschützes benutzt werden. Diese Funktion ist wichtig für 4- Quadranten-Antriebe. Das Hauptschütz darf nicht während der Energie-Rückspeisung ins Netz geöffnet werden.

Die korrekte Sequenz ist

1. den Rückspeisestrom abschalten
2. das Hauptschütz öffnen

Wenn NOT-AUS (Not-Halt) gedrückt wird, wird die Meldung über Digitaleingang DI5 an den Stromrichter gesendet. Bei

Rampenstopp oder max. Drehmoment verzögert der Stromrichter den Motor und öffnet dann das Hauptschütz.

Wenn der Stromrichter die Funktion nicht innerhalb der mit Timer K15 eingestellten Zeit ausgeführt hat, muss der Stromrichter den Befehl zum Abschalten des Stroms über K16 erhalten. Nach Ablauf der mit Timer K16 eingestellten Zeit wird das Hauptschütz unabhängig vom Status des Stromrichters geöffnet.

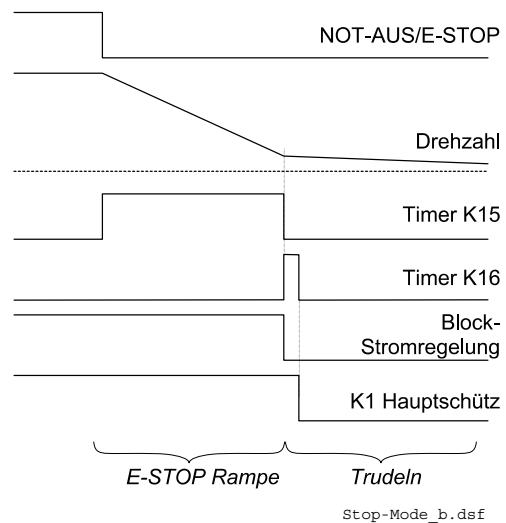
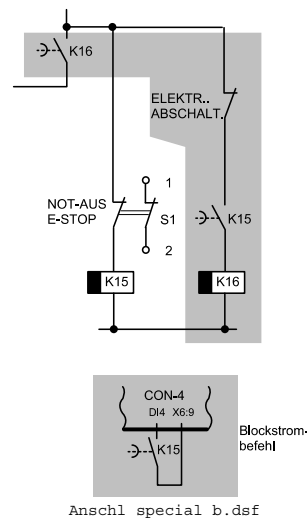

Reaktion bei Not-Aus/E-STOP

Lüfterkühlung

Lüfterzuordnung for DCS800

Stromrichtertyp	Model	Konfiguration	Lüfterspannung
DCS800-S01-0020-04/05 DCS800-S02-0025-04/05	D1	-	kein Lüfter
DCS800-S0x-0045-04/05... DCS800-S0x-0140-04/05	D1	1	115 oder 230 VAC
DCS800-S0x-0180-04/05... DCS800-S0x-0260-04/05	D2	1	115 oder 230 VAC
DCS800-S0x-0315-04/05... DCS800-S0x-0350-04/05	D3	1	115 oder 230 VAC
DCS800-S0x-0405-04/05... DCS800-S0x-0520-04/05	D3	2	115 oder 230 VAC
DCS800-S0x-0610-04/05... DCS800-S0x-0820-04/05	D4	3	230 VAC
DCS800-S0x-0610-04/05... DCS800-S0x-0820-04/05	D4 Pluscode S171	3	115 VAC
DCS800-S0x-0900-04/05... DCS800-S0x-1000-04/05	D4	3	230 VAC
DCS800-S0x-0900-04/05... DCS800-S0x-1000-04/05	D4 Pluscode S171	3	115 VAC

Lüfteranschluss für DCS800

Anschlüsse oben auf dem Stromrichtergehäuse

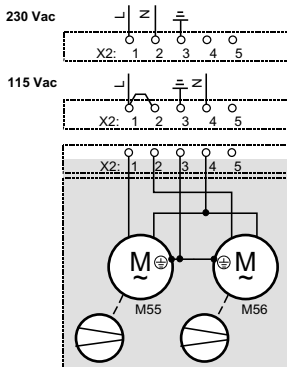

Konfiguration 1
D1-D3

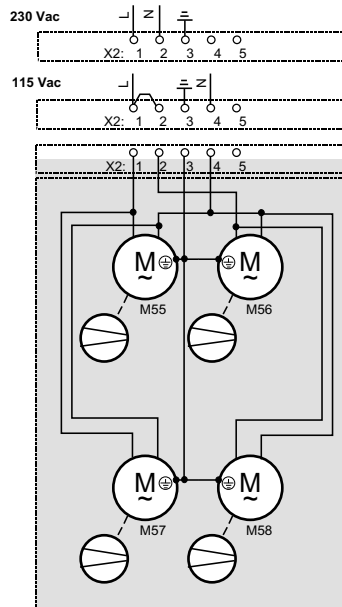

Konfiguration 2
D3

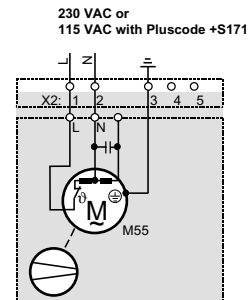

DCS8 fan conn D1-D4.dsf

Konfiguration 3
D4

Klemmen- und Steckeranordnung des Stromrichters

SDCS-CON-4 Steckeranschlüsse

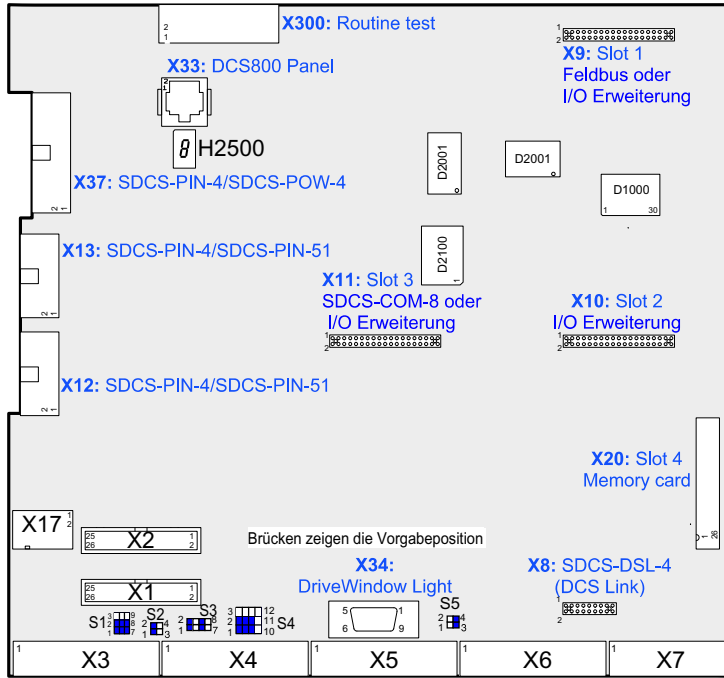

DCS800 Modul

ANSCHLUSSKLEMMEN

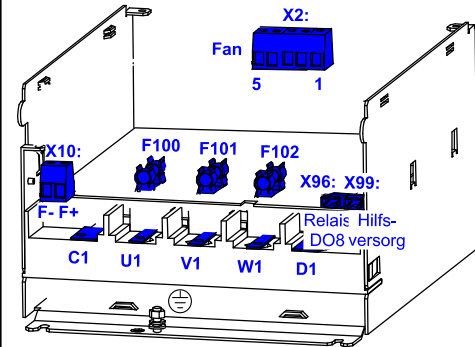

DCS800 Zubehör

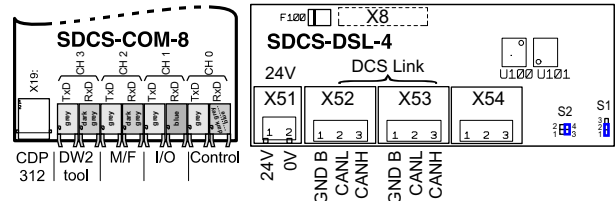

SDCS-CON-4: KLEMMENZUORDNUNG

X3 Tacho and AI		X4 AI and AO		X5 Encoder		X6 DI		X7 DO	
1	2	1	2	1	2	1	2	1	2
90...270V	30...90V	0V	0V	+A	+B	DI1	DI2	DO1	DO2
8...30V	AI1+	AI1+	AI2+	-A	-B	DI3	DI4	DO3	DO4
	AI2-	AI2-	AI3+	-Z	-Z	DI5	DI6	DO5	DO6
	AI3+	AI3+	AI4+	GND	GND	DI7	DI8	DO7	DO7
	AI4+	AI4+	AO1	Sense GND	Sense Us	+24	0V		
	AO2	AO2	AO3 (fact)						
	AO3	AO3	0V						

DCS800 terminal alloc_a.dsf

Macro-Finder

Macro Name	Haupt-schutz	ON / OFF Start/Stop	DI Funktion	Kommentar	DI5 -> ESTOP DI6 -> Reset
Standard					
	AC	Static	Jog1 -> DI1 Jog2 -> DI2 Ext Fault -> DI 3 Ext Alarm -> DI4	Hardware I/O Steuerung	x
2-wire DC cont. US					
	DC	Static	Jog1 -> DI1 Jog2 -> DI2 Ext Fault -> DI 3 Main Cont Ack -> DI4	Hardware I/O Steuerung	x
3-wire DC cont. US					
	DC	Pulse	Fix speed1 -> DI1 Ext Fault -> DI 3 Main Cont Ack -> DI4	Hardware I/O Steuerung	x
3-wire Standard					
	AC	Pulse	Fix speed1 -> DI1 Ext Fault -> DI 3 Ext Alarm -> DI4	Hardware I/O Steuerung	x
Torque limit					
	AC	Static	Jog1 -> DI1 Jog2 -> DI2 Ext Fault -> DI 3 Ext Alarm -> DI4	Hardware I/O Steuerung + Torque limit	x
Manual / Const					
	AC	Pulse	Jog1 -> DI1 Jog2 -> DI2 Direction -> DI 3 SpC - KP, KI -> DI4	Hardware I/O Steuerung Verstärkung auswählen	x
Hand / Auto					
	AC	Static	Control select -> DI2 Reference select -> DI2 Direction select -> DI 3	Hardware I/O Steuerung oder Feldbussteuerung	x
Hand / Mot Pot					
	AC	Pulse	Motor pot up -> DI1 Motor pot down -> DI2 Direction select -> DI 3 Reference select -> DI4	Hardware I/O Steuerung Sollwert durch Hardware oder Motorpotentiometer	x
Motor Pot					
	AC	Static	Direction select -> DI 1 Motor pot up -> DI2 Motor pot down -> DI3 Motor pot minimum -> DI4	Hardware I/O Steuerung Sollwert durch Motor poten- tiometer	x
Torque Ctrl					
	AC	Static	OFF2 (coast stop) -> DI1 Torque select -> DI2 Ext Fault -> DI 3	Hardware I/O Steuerung Drehzahlregelung oder Mo- mentensollwert	x

Macro auswählen

benutze den [DCS800Wizard] 2. Macro assistant im DriveWindow Light oder

Parameter Menue, der Steuertafel, oder von DriveWindow, oder DriveWindow Light.

Benutze folgende Parameter:

- AppMacro (99.08) = Macroauswahl
- Apprestore (99.07) = YES = aktivieren
- MacroSel (8.10) = Überprüfung

ANMERKUNG Funktionen und Eingänge die durch das Macro bestimmt werden können später ohne Einschränkung geändert werden.

ANMERKUNG Macro diagram siehe Seite 93 ...

Sicherheits- und Anwendungshinweise



für Antriebsstromrichter DCS / DCF / DCR

(gemäß: Niederspannungsrichtlinie 73/23/EWG)

1. Allgemein

Während des Betriebes können Antriebsstromrichter ihrer Schutzart entsprechend spannungsführende, blanke, gegebenenfalls auch bewegliche oder rotierende Teile, sowie heiße Oberflächen besitzen.

Bei unzulässigem Entfernen der erforderlichen Abdeckung, bei unsachgemäßem Einsatz, bei falscher Installation oder Bedienung, besteht die Gefahr von schweren Personen- oder Sachschäden.

Weitere Informationen sind der Dokumentation zu entnehmen.

Alle Arbeiten zum Transport, zur Installation und Inbetriebnahme sowie zur Instandhaltung sind von qualifiziertem Fachpersonal auszuführen (IEC 364 bzw. CENELEC HD 384 oder DIN VDE 0100 und IEC 664 oder DIN VDE 0110 und nationale Unfallverhütungsvorschriften beachten).

Qualifiziertes Fachpersonal im Sinne dieser grundsätzlichen Sicherheitshinweise sind Personen, die mit Aufstellung, Montage, Inbetriebsetzung und Betrieb des Produktes vertraut sind und über die ihrer Tätigkeit entsprechenden Qualifikationen verfügen.

2. Bestimmungsgemäße Verwendung

Antriebsstromrichter sind Komponenten, die zum Einbau in elektrische Anlagen oder Maschinen bestimmt sind.

Bei Einbau in Maschinen ist die Inbetriebnahme der Antriebsstromrichter (d.h. die Aufnahme des bestimmungsgemäßen Betriebes) solange untersagt, bis festgestellt wurde, dass die Maschine den Bestimmungen der EG-Richtlinie 89/392/EWG (Maschinenrichtlinie) entspricht; EN 60204 ist zu beachten.

Die Inbetriebnahme (d.h. die Aufnahme des bestimmungsgemäßen Betriebes) ist nur bei Einhaltung der EMV-Richtlinie (89/336/EWG) erlaubt.

Die Antriebsstromrichter erfüllen die Anforderungen der Niederspannungsrichtlinie 73/23/EWG. Die harmonisierten Normen der Reihe prEN 50178/DIN VDE 0160 in Verbindung mit EN 60439-1/VDE 0660 Teil 500 und EN 60146/VDE 0558 werden für die Antriebsstromrichter angewendet.

Die technischen Daten sowie die Angaben zu Anschlussbedingungen sind dem Leistungsschild und der Dokumentation zu entnehmen und unbedingt einzuhalten.

3. Transport, Einlagerung

Die Hinweise für Transport, Lagerung und sachgemäße Handhabung sind zu beachten.

Klimatische Bedingungen sind entsprechend prEN 50178 einzuhalten.

4. Aufstellung

Die Aufstellung und Kühlung der Geräte muss entsprechend den Vorschriften der zugehörigen Dokumentation erfolgen.

Die Antriebsstromrichter sind vor unzulässiger Beanspruchung zu schützen. Insbesondere dürfen bei Transport und Handhabung keine Bauelemente verbogen und/oder Isolationsabstände verändert werden. Die Berührung elektronischer Bauelemente und Kontakte ist zu vermeiden.

Antriebsstromrichter enthalten elektrostatisch gefährdete Bauelemente, die leicht durch unsachgemäße Behandlung beschädigt werden können. Elektrische Komponenten dürfen nicht mechanisch beschädigt oder zerstört werden (unter Umständen Gesundheitsgefährdung!).

5. Elektrischer Anschluss

Bei Arbeiten an unter Spannung stehenden Antriebsstromrichtern sind die geltenden nationalen Unfallverhütungsvorschriften (z.B. VBG 4) zu beachten.

Die elektrische Installation ist nach den einschlägigen Vorschriften durchzuführen (z.B. Leitungsquerschnitte, Absicherungen, Schutzleiteranbindung). Darüberhinausgehende Hinweise sind in der Dokumentation enthalten.

Hinweise für die EMV-gerechte Installation - wie Schirmung, Erdung, Anordnung von Filtern und Verlegung der Leitungen - befinden sich in der Dokumentation der Antriebsstromrichter. Diese Hinweise sind auch bei CE-gekennzeichneten Antriebsstromrichtern stets zu beachten. Die Einhaltung der durch die EMV-Gesetzgebung geforderten Grenzwerte liegt in der Verantwortung des Herstellers der Anlage oder Maschine.

6. Betrieb

Anlagen, in die Antriebsstromrichter eingebaut sind, müssen ggf. mit zusätzlichen Überwachungs- und Schutzeinrichtungen gemäß den jeweils gültigen Sicherheitsbestimmungen, z.B. Gesetz über technische Arbeitsmittel, Unfallverhütungsvorschriften usw. ausgerüstet werden. Veränderungen der Antriebsstromrichter mit der Bediensoftware sind gestattet.

Nach dem Trennen der Antriebsstromrichter von der Versorgungsspannung dürfen spannungsführende Geräteteile und Leistungsanschlüsse wegen möglicherweise aufgeladener Kondensatoren nicht sofort berührt werden. Hierzu sind die entsprechenden Hinweisschilder auf dem Antriebsstromrichter zu beachten.

Während des Betriebes sind alle Abdeckungen und Türen geschlossen zu halten.

7. Wartung und Instandhaltung

Die Dokumentation des Herstellers ist zu beachten.

Diese Sicherheitshinweise sind aufzubewahren!

Installation der DCS800 Programme auf dem PC

Nachdem die DCS800 CD eingelegt wurde werden alle Programme und Dokumente, die nötig sind um mit den DCS800 zu arbeiten, automatisch installiert.

Inhalt:

1. DriveWindow Light zu Parametrisierung, Inbetriebnahme und Service
2. Hitachi FDT 2.2 zum Laden der Firmware
3. DCS800 Komponenten z.B. DWL Assistent, ABB Dokumente
4. CoDeSys für die 61131 Applikationsprogrammierung

Achtung:

Fall ein Programm nicht installiert werden soll, einfach die dazugehörige Installationsroutine mit Hilfe von Abbrechen überspringen.



Falls die Installation nicht automatisch startet:

- Start drücken, dann Ausführen und Durchsuchen der CD nach setup.exe. Danach die Installation mit OK starten
- Eine Kurzinstallation mit Auswahl von DriveWindow Light + Inbetriebnahme Assistent und DriveWindow Light AP wird empfohlen

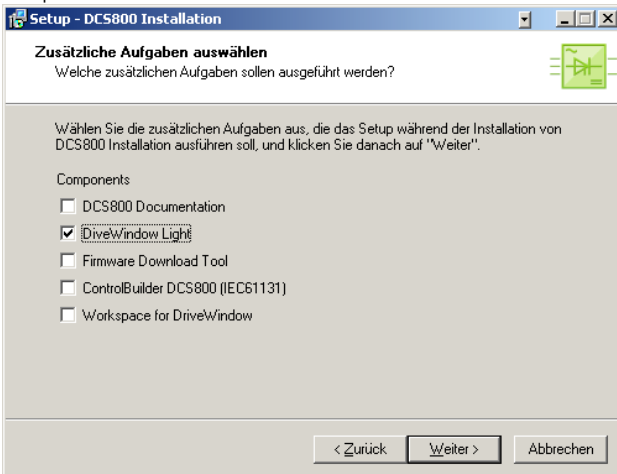

Verbindung zum Antrieb herstellen

- Die Dokumentation kann unter **C:\ABB\DCS800\Docu** gefunden werden
- Den Gerätedeckel vom Stromrichtermodul entfernen

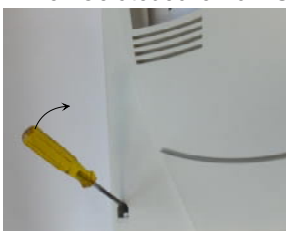

Die DCS800 Steuertafel entfernen falls vorhanden. Die Sperren herunterdrücken um den Deckel zu entfernen



Den Antrieb (X34) mit dem PC über einen COM Port verbinden

- DriveWindow Light starten
Die Kommunikationseinstellungen des COM Ports überprüfen

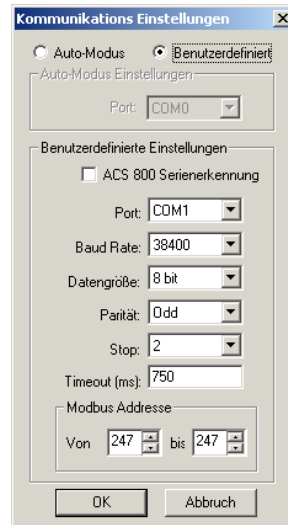

Falls ein USB / COM oder PCMCIA / COM Adapter benutzt wird bitte die Einstellungen des COM Ports überprüfen
Start => Einstellungen => Systemsteuerung System => Hardware => Geräte-Manager

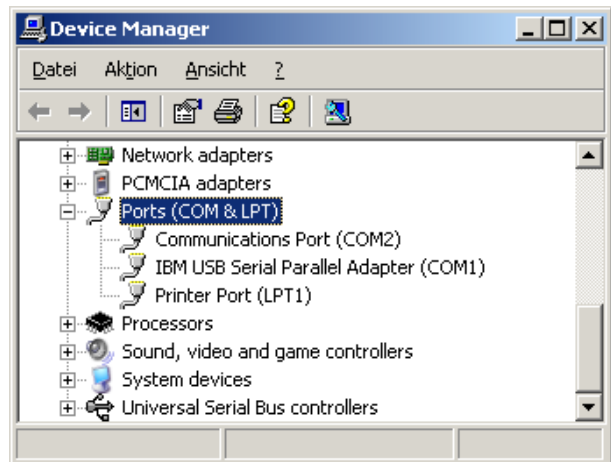

Die COM Adresse des USB Adapters kann sich nach dem nächsten Booten oder bei erneutem Anschluss ändern.

Hinweis:

PCMCIA / COM Adapter stellen eine sicherere und schneller Verbindung zum Antrieb her.

Um DriveWindow Light oder dem DCS800 Steuertafelassistent zu benutzen mit Kapitel Inbetriebnahme fortfahren.

Für die Inbetriebnahme mit DriveWindow mit dem Kapitel Workspaces im DCS800 Firmware Manual fortfahren.

Inbetriebnahme



Vorsicht! Hochspannung: Dieses Symbol warnt vor hohen Spannungen, die eine Verletzungsgefahr darstellen und/oder Schäden an der Anlage verursachen können. Neben dem Symbol werden ggf. geeignete Vorsichtsmaßnahmen zur Vermeidung dieser Gefahren beschrieben.



Allgemeine Warnung: Dieses Symbol warnt vor nicht elektrischen Gefahren, die zu schweren oder sogar tödlichen Verletzungen von Personen und/oder Schäden an Geräten führen können. Der Text neben diesem Symbol beschreibt ggf. Möglichkeiten zur Vermeidung dieser Gefahr.



Warnung vor elektrostatischer Entladung: Dieses Symbol warnt vor elektrostatischen Entladungen, die zu Schäden an Geräten führen können. Neben dem Symbol werden ggf. geeignete Vorsichtsmaßnahmen zur Vermeidung dieser Gefahren beschrieben.

NEC Motorüberlastschutz

Der DCS800 stellt einen elektronischen Motorüberlastschutz in Übereinstimmung mit NEC bereit. Der Überlastschutz (z.B. Schutzwelle in Prozent vom Vollaststrom des Motors) kann mit Parametern in den Gruppen 31 und 99 eingestellt werden. Die Anweisungen können dem Kapitel Thermisches Motormodell im DCS800 Firmware Handbuch entnommen werden.

Allgemeine Hinweise

- Diese Kurzinbetriebnahme bezieht sich auf Kapitel 5 Anschlussbeispiele dieser Druckschrift.
- *Sicherheits- und Anwendungshinweise* - siehe Kapitel 6 dieser Druckschrift.
- Empfehlungen von Motor- und Feldspannungen siehe Technischer Katalog.
- Gemäß DIN 57100 Teil 727 / VDE 0100 Teil 727 sind Vorkehrungen zu treffen um den Antrieb z.B. im Gefahrenfall still setzen zu können. Die digitalen Eingänge des Gerätes oder die Steuertafel reichen dazu als alleinige Maßnahme nicht aus!

Vorbereitende Arbeiten

- Gerät auf eventuelle Schäden überprüfen!
- Gerät montieren und verdrahten
- Versorgungsspannung / Nennspannung für Elektronik und Lüfter korrekt?
- Versorgungsspannung / Nennspannung für Ankerstromrichter korrekt?
- Versorgungsspannung / Nennspannung für Feldversorgung korrekt?
- Verdrahtung / Querschnitte, etc korrekt?
- NOT-HALT funktionstüchtig?
- NOT-AUS funktionstüchtig?

Inbetriebnahme mit DriveWindow Light

Aufrufen der Assistenten in DriveWindow Light:

Um die Basisinbetriebnahme aufzurufen auf **Start** drücken oder gezielt einen Assistenten aufrufen: Einen Assistenten auswählen & auf **Weiter** drücken

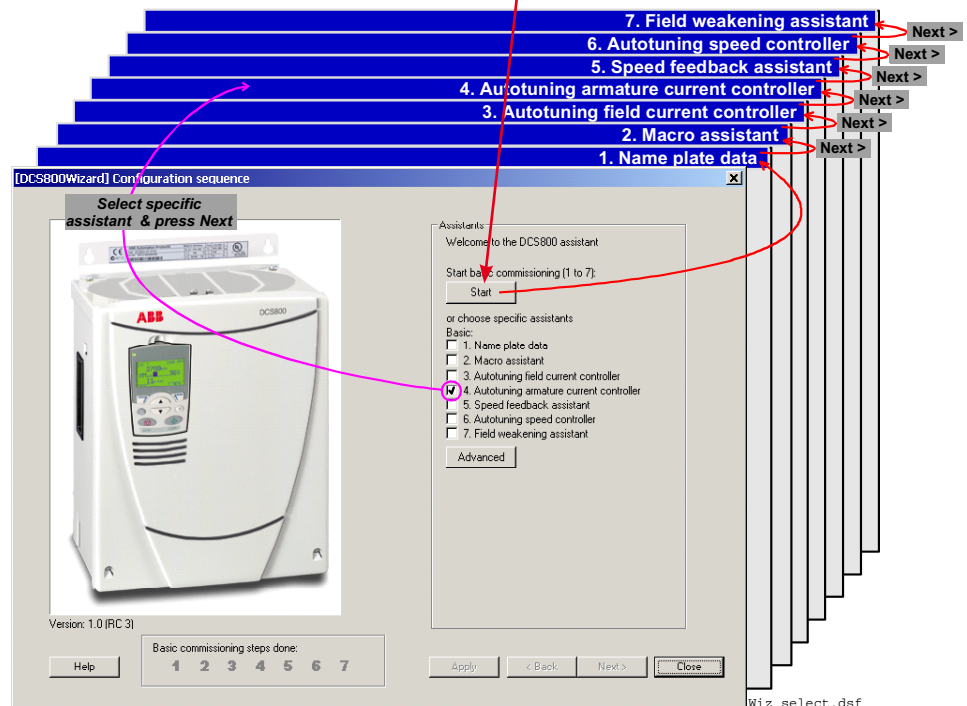
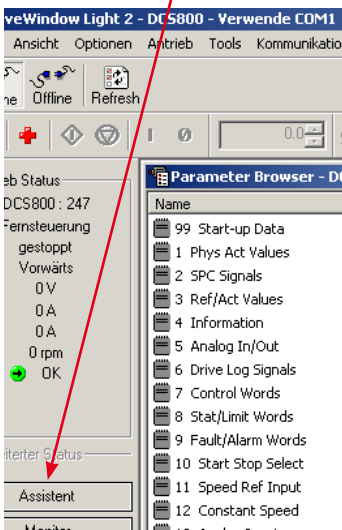

Um zusätzliche Informationen über die Assistenten, Parameter, Fehler und Alarmer zu erhalten auf **Hilfe** drücken!

DCS800-Steuertafel

In der folgenden Abbildung sind die Tastenfunktionen und Anzeigen der DCS800-Steuertafel dargestellt..

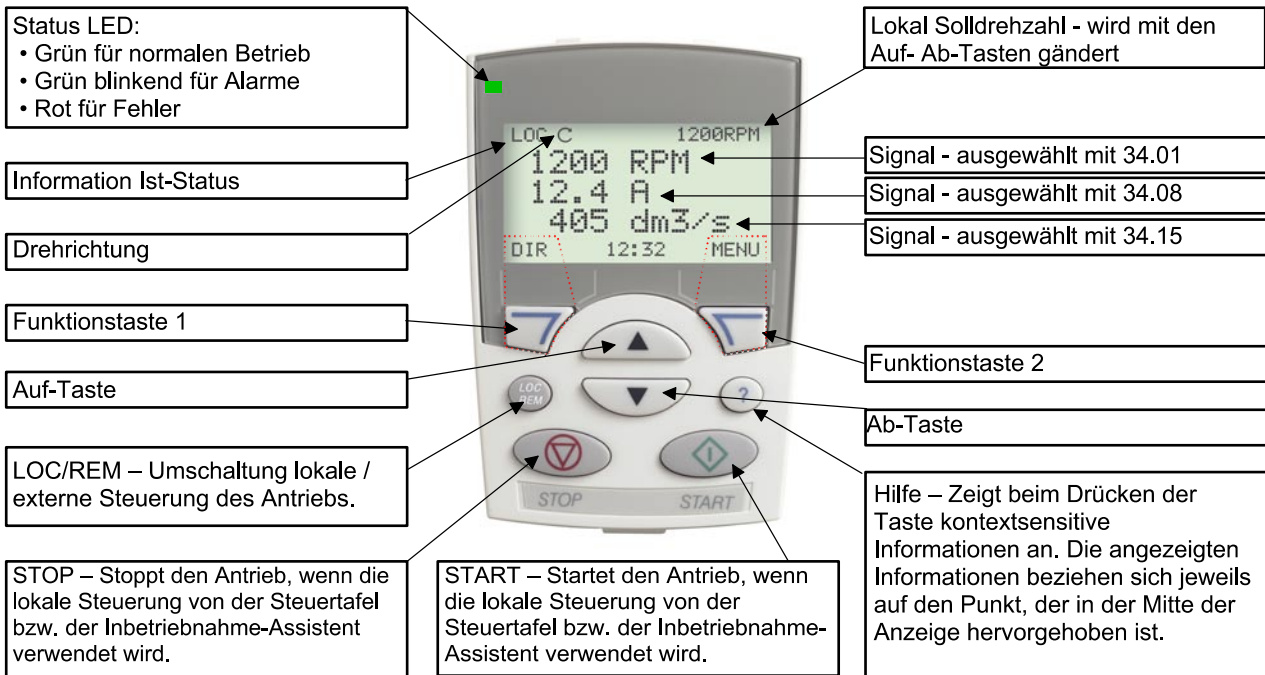

DCS800_QG_pan_ov_b.ds#f

Mit USISel (16.09) ist es möglich die Menge der Parameter, die angezeigt werden, zu reduzieren.

Allgemeine Displayfunktionen

Folgende Modi sind im HAUPMENÜ vorhanden:

1. Modus Parameter
2. Modus Inbetriebnahme-Assistenten
 - a. Typenschild Daten
 - b. Makro Assistent
 - c. Selbsteinstellung Feldstromregler
 - d. Selbsteinstellung Ankerstromregler
 - e. Drehzahlrückführungs Assistent (Der Tachofeinabgleich ist nicht vorhanden)
 - f. Selbsteinstellung Drehzahlregler
 - g. Feldschwächungs-Assistent (wird nur verwendet, wenn die Maximaldrehzahl höher ist als die Grunddrehzahl)
3. Modus Makros (wird derzeit nicht verwendet)
4. Modus geänderte Parameter (Auflistung aller Parameter, deren Grundeinstellung geändert wurde)
5. Modus Fehlerspeicher (Fehlerprotokoll anzeigen)
6. Modus Uhreinstellung
7. Parametersicherung
 - kopiert den aktuellen Parametersatz vom Antrieb in die DCS800-Steuertafel (nur im Lokalbetrieb)
 - kopiert den Parametersatz von der DCS800-Steuertafel in den Antrieb (nur im Lokalbetrieb)
8. Modus E/A-Einstellungen (wird derzeit nicht verwendet)

Parameter, die über den Assistenten eingegeben werden

99.02	Motor 1 Nennspannung
99.03	Motor 1 Nennstrom
99.04	Motor 1 Nenndrehzahl
20.01	Motor 1 Minimaldrehzahl
20.02	Motor 1 Maximaldrehzahl
99.11	Motor 1 Feldnennstrom
30.09	Ankerüberstromschwelle
30.16	Motor 1 Überdrehzahl
99.10	Netzennspannung
99.12	Motor 1 verwendeter Feldstellertyp
20.05	maximales Drehmoment
20.06	minimales Drehmoment
20.12	Motor 1 Strombegrenzung Brücke 1
20.13	Motor 1 Strombegrenzung Brücke 2
50.04	Motor 1 Impulszahl Impulsgeber 1, wenn ausgewählt
50.02	Motor 1 Impulsgeber 1 Messmodus, wenn ausgewählt
50.13	Motor 1 Tachospaltung bei 1000 U/min, nur DWL
50.12	Motor 1 Tachoabgleich, nur DWL
20.03	Schwelle Nulldrehzahl
22.01	Beschleunigungszeit 1
22.02	Verzögerungszeit 1
30.12	Motor 1 Feldsteller Unterstrom
44.01	Wahlschalter Steuermodus Feld



Caratteristiche Standard

- Compatto
- Per alta potenza
- Semplice da usare
- Assistente comodo, es. per autotaratura e messa in servizio
- Adattabile a tutte le applicazioni
- Programmazione libera per mezzo di un PLC-IEC61131 integrato

DCS800 DC Drives

Dati tecnici

Tensione di alim. 230...1,200 V,
principale: +/-10%, trifase
Frequenza nominale: 50...60 Hz,
+/-5 Hz
Alimentazione per 115...230 V,
l'elettronica: -15% / +10%,
1~
Valori di corrente in CC: 20...5.200 A
Capacità di sovraccarico: 200%

Condizioni ambientali

Temperatura 0° ... +40° C
ambiente: 40° ... 55° C con
riduzione
Temp. magazzino: -40° ... +55° C
Temp. di trasporto: -40° ... +70° C
Temp. di trasporto: 5 ... 95%, senza
condensa (max.
50% fra 0°...5° C)
Grado d' inquinamento: Classe 2
Classe di protezione: IP 00
Altitudine < 1000 m s.l.m.:
alla corrente
nominale
> 1000 m s.l.m.
con riduzione

I/O

Ingressi digitali: 8 standard, fino
a 14 opzionali
Uscite digitali: 8 standard, fino
a 12 opzionali
Ingressi analogici: 4 standard
+/-10 V; 0/2...10 V, fino a 8 opzio-
nali +/- 20 mA; 0/4...20 mA
Uscite analogiche: 3 standard
(1x I_{act}) +/-10 V; 0/2...10 V, fino a 7
opzionali -20 mA; 0/4...20 mA

PC-Tools

DriveWindow Light: gratuito
con ogni convertitore, connesio-
ne al PC Standard RS232
DriveWindow: connessione
ottica in tempo reale
ControlBuilder DCS800:
tool di programmazione IEC61131
DriveSize: dimensionamento
Convertitore e Motore

Manutenzione / Diagno- stica

Diagnostica remota in tutto il
mondo con Internet_PC
• Con Internet browser / internet
explorer
• Oppure controllo completo del
drive con DriveWindow via OPC

Approvazioni



Programmazione adattiva

Blocchi funzione pre-definiti, es.
• Regolatore processo libero
(Regolatore PI)
• I/O e funzioni digitali
con pannello di controllo o PC
Tool, senza hardware addizionale

Retroazione di Velocità

EMF
Tachimetrica analogica
Encoder
Secondo Encoder possibile
(RTAC)

Comunicazione

Comunicazione seriale
• Ethernet • Profibus
• CANopen • DeviceNet
• ControlNet • DDCS
• Modbus
• CS31 • AF100
• Selma2
Autorizzato Industrial IT®

DCSLink Peer-to-Peer

• Fino a 800 Kbaud, <2,5 ms
• Master-Follower
• Convertitore armatura-campo
• Dati selezionabili liberamente

Soluzioni per Alte Correnti

• 12 impulsi fino a 20.000A, serie
e parallelo
• Parallelo rigido e sequenziale
• Fino a 1500 V

Funzioni di protezione

Errore di retroazione velocità •
Sovratemperatura • Sovraccarico
• Sovravelocità • Stallo motore •
Sovracorrente motore • Sovraten-
sione motore • Sovracorrente di
campo • Sovratensione di campo
• Minima corrente di campo •
Velocità zero • Ripple corrente
armatura • Sovra- e sottotensione
rete

PLC integrato IEC 61131

• Tool di programmazione
standard ControlBuilder
• Supporta tutti e cinque i
linguaggi IEC
• Blocchi funzione specifici per
drive
• Salvataggio programma e
sorgente su Memory Card
• Debugging e forzatura online

Correnti nominali, Dimensioni

Taglia unità	2-Q corrente nominale DCS800-01 I _{DC} [A]	4-Q corrente nominale DCS800-02 I _{DC} [A]	Tensione di rete [V _{AC}]							Corrente max. campo interno [A _{DC}]	Dimensioni	
			400	525	600	690	800	990	1200		h x w x d [mm]	h x w x d [inch]
D1	20	25	●	●					6	370 x 270 x 200	14,56 x 10,65 x 7,90	
	45	50	●	●								
	65	75	●	●								
	90	100	●	●								
	125	140	●	●								
D2	180	200	●	●				15	370 x 270 x 270	14,56 x 10,65 x 10,65		
	230	260	●	●								
D3	315	350	●	●	● ³⁾			20	459 x 270 x 310	18,07 x 10,65 x 12,25		
	405	450	●	●								
	470	520	●	●								
D4	610	680	●	●	● ³⁾			25	644 x 270 x 345	25,35 x 10,65 x 13,60		
	740	820	●	●								
	900	1000	●	●								
D5	900	900	●	●	●	●		25	1050 x 510 x 410	41,35 x 20,10 x 16,15		
	1200	1200	●	●								
	1500	1500	●	●	●	●						
	2000	2000	●	●	● ¹⁾	● ¹⁾						
D6	1900	1900		●	●	●	●	campo esterno 35A, 1~/3~ 50/60A, 1~ 520A, 3~	1750 x 460 x 410	68,90 x 18,15 x 16,15		
	2050	2050		●	●	●						
	2500	2500	●	●	●	●						
	3000	3000	●	●	●	●						
D7	2050	2050		●	●	●	●	campo esterno 35A, 1~/3~ 50/60A, 1~ 520A, 3~	1750 x 760 x 570	68,90 x 29,95 x 22,45		
	2600	2600		●	●	●	● ²⁾					
	3300	3300	●	●	●	●	● ²⁾					
	4000	4000	●	●	●	●						
	4800	4800	●	●	●	●						
	5200	5200	●	●								

●¹⁾ Disponibile solo per drive 2-Q

●²⁾ Su richiesta

●³⁾ 600V

2-Q -> 290 A / 590 A
4-Q -> 320 A / 650 A

Brevi istruzioni per CD ed informazioni generali sui documenti

La ringraziamo per l'acquisto di un convertitore di potenza per azionamenti in cc ABB e per la fiducia accordata ai nostri prodotti.

Per garantire la sua completa soddisfazione nei nostri prodotti, abbiamo redatto la presente brochure, con l'intento di presentare in sintesi, i principali dati del prodotto, alcune note sulle EMC, impieghi tipici, messa in servizio e guida alla risoluzione dei guasti.

Qualora desideri ulteriori informazioni sul prodotto, oltre alla presente documentazione troverà un **CD-ROM**. Il CD-ROM è parte integrante di questo documento e contiene quanto segue:

Documentazione

La nostra documentazione si articola come segue:

Catalogo tecnico (3ADW000192)

Informazioni complete sulla struttura del sistema del convertitore di potenza in generale.

Manuale Hardware (3ADW000194)

Informazioni dettagliate complete di tutti i particolari sui singoli componenti, quali dimensioni moduli, schede elettroniche, ventilatori e componenti ausiliari.

Sono anche incluse informazioni sull'installazione meccanica ed elettrica.

Manuale Software (3ADW000193)

Informazioni dettagliate di tutti gli argomenti riguardanti il software e l'impostazione dei parametri. Il manuale include tutte le informazioni relative a messa in servizio e manutenzione dell'intero azionamento, in forma dettagliata.

Manuale di manutenzione (3ADW000195)

Per interventi di manutenzione e riparazione dei convertitori.

Applications

DCS800 DC Drive can include application software e.g. cranes, winders. In such case following procedures and assistants can be blocked or not completed. Please check for further documentation and manuals (check parameter 4.03, 83.01).

Inoltre, **diverse informazioni sulle applicazioni** (ad esempio 12 impulsi) e **accessori tecnici** (ad esempio estensioni hardware e interfacce fieldbus) descritte da manuali separati, vedi tabella dei *manuali dell'azionamento DCS800*.

Requisiti di sistema per l'utilizzo del CD-ROM

- Sistema operativo WINDOWS 2000, XP
- ADOBE READER 4.0 è sufficiente (noi raccomandiamo 8.0 – incluso nel CD-ROM)



Se il CD ROM non si avvia automaticamente, fare doppio clic su **Setup.exe**

Ulteriore supporto

Restiamo inoltre a Sua completa disposizione con un servizio di assistenza volto a garantire la soddisfazione del cliente – da sempre una nostra priorità assoluta.

Internet

Nella homepage di ABB all'indirizzo

www.abb.com/dc

troverete una serie di informazioni relativamente a

- prodotti in c.c.
- assistenza
- ultimi aggiornamenti
- strumenti
- download, ecc.

La invitiamo a visitare il nostro sito Web.

Contatti

Per ulteriori informazioni potrà rivolgersi alla sede **ABB Drives** locale oppure inviare una e-mail all'indirizzo:

DC-Drives@de.abb.com

indicando nome, società, indirizzo e numero di telefono. Sarà nostra premura comunicarle tempestivamente la persona di riferimento che potrà contattare.

Note sulla EMC

Troverai ulteriori informazioni nella pubblicazione:

Technical Guide chapter: EMC Compliant Installation and Configuration for a Power Drive System

Il seguente paragrafo descrive la selezione di componenti elettrici in conformità alla normativa EMC.

Lo scopo di tale normativa, com'è implicito nel nome, consiste nell'assicurare la compatibilità elettromagnetica con altri prodotti e sistemi. Tale normativa è volta a garantire che le emissioni dal prodotto in esame siano al di sotto del livello che potrebbe danneggiare l'immunità all'interferenza di altri prodotti.

Nell'ambito della normativa EMC vanno considerati due aspetti:

- l'immunità alle interferenze del prodotto
- le effettive emissioni del prodotto

La normativa EMC prevede che gli aspetti relativi alla compatibilità elettromagnetica siano valutati già nella fase di sviluppo del prodotto; tuttavia non è possibile predeterminare il grado di compatibilità elettromagnetica di un prodotto, poiché esso può essere misurato solo quantitativamente.

Nota relativa alla conformità elettromagnetica

La procedura di conformità è responsabilità congiunta del fornitore del convertitore e del produttore della macchina o sistema che lo utilizza, in base alla rispettiva responsabilità nell'espansione delle apparecchiature elettriche considerate.

Primo ambiente (area residenziale con industria leggera) con PDS categoria C2	
Non applicabile, poiché sono esclusi i canali commerciali generali di ottenibilità	
Non applicabile	conforme
conforme	

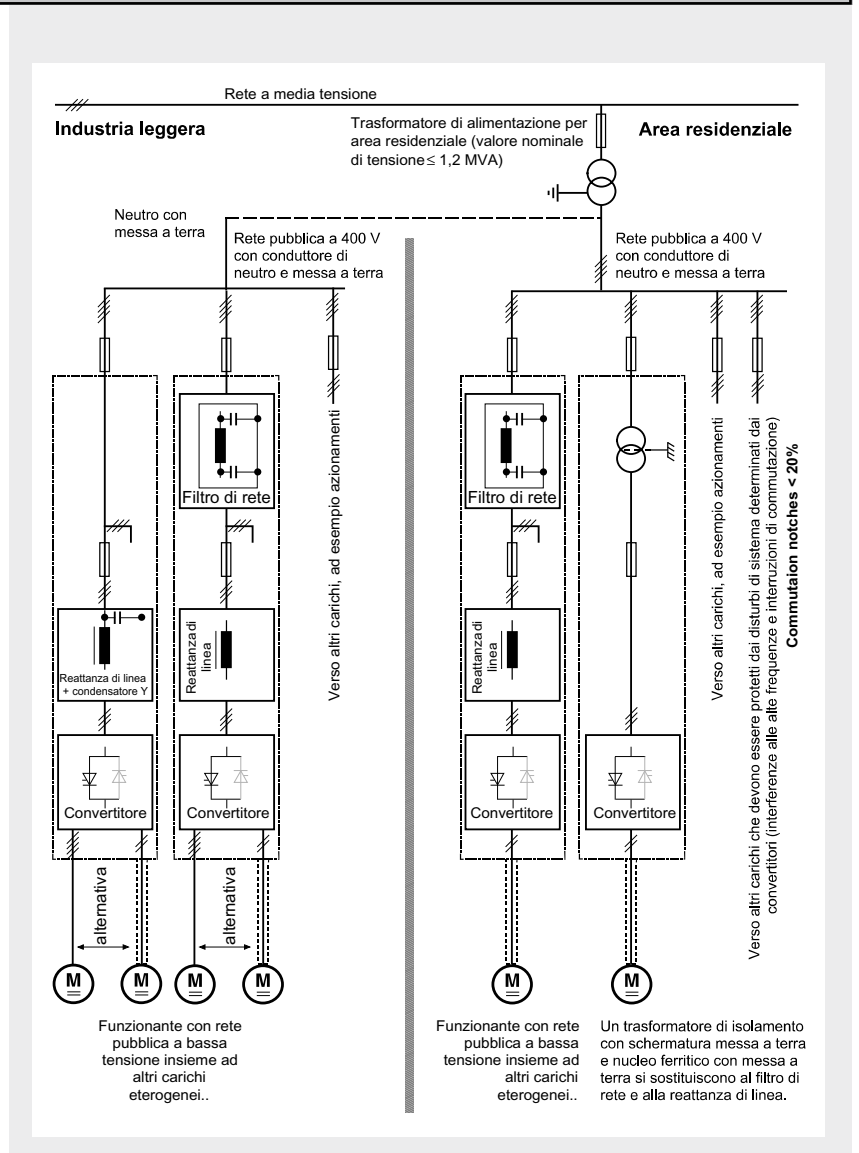
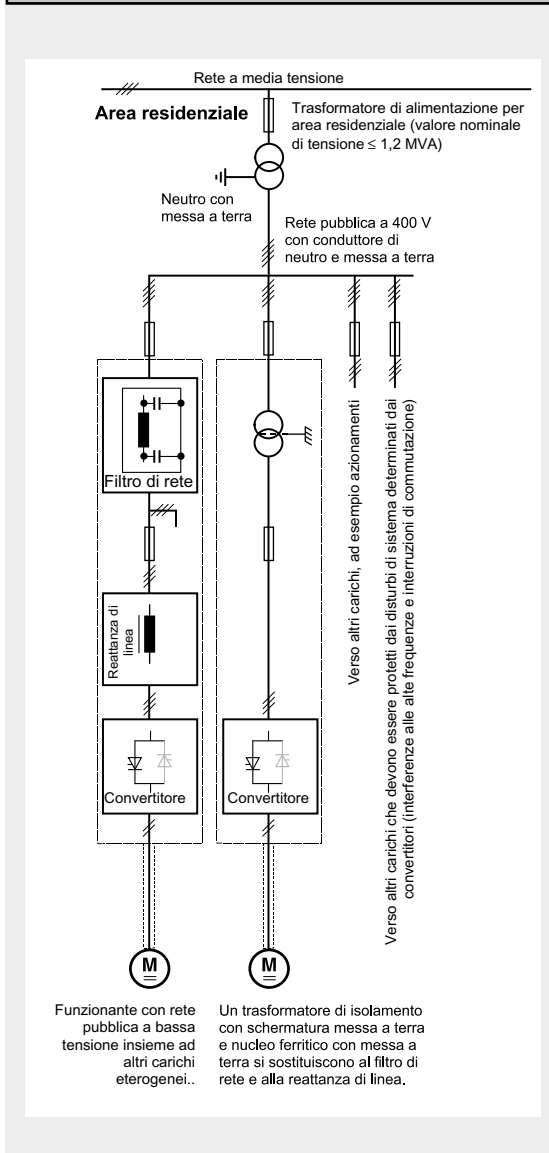

Per assicurare la conformità agli obiettivi di protezione della legge tedesca sulla compatibilità elettromagnetica (EMVG) in sistemi e macchine, devono essere rispettate le seguenti norme sulla compatibilità elettromagnetica:

Norma di prodotto EN 61800-3

Norma EMC per azionamenti (PowerDriveSystem), immunità alle interferenze ed emissioni in aree residenziali, zone industriali con insediamenti di industria leggera e presso stabilimenti industriali.

La norma va rispettata nell'ambito dell'UE per rispondere ai requisiti di compatibilità elettromagnetica di sistemi e macchine!

Per quanto riguarda le interferenze emesse, sono applicabili le seguenti norme:

EN 61000-6-3 Norma specifica di base per emissioni nell'ambito dell'**industria leggera** che può essere rispettata con dispositivi speciali (filtri di rete, cavi di potenza schermati) nelle gamme di potenza inferiori *(EN 50081-1).

EN 61000-6-4 Norma speciale di base per le emissioni in **ambito industriale** *(EN 50081-2).

Per le interferenze emesse, sono applicabili le seguenti norme:

EN 61000-6-1 Norma specifica di base per l'immunità alle interferenze in **aree residenziali** *(EN 50082-1)

EN 61000-6-2 Norma specifica di base per l'immunità alle interferenze in **ambito industriale**. Se si ottempera a questa norma, la norma EN 61000-6-1 viene automaticamente rispettata *(EN 50082-2).

* Gli standard generici sono messi tra parentesi.

			Norme
Secondo ambiente (industria) con PDS categoriai C3, C4			EN 61800-3
Non applicabile			EN 61000-6/3
conforme	presso il cliente	conforme	EN 61000-6/3
conforme			EN 61000-6-2 EN 61000-6-1

italiano

PDS categoria C3

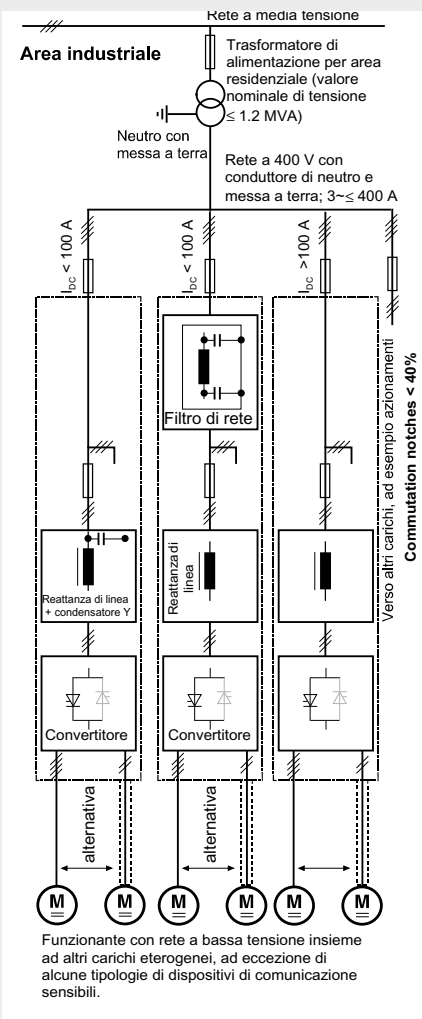

PDS categoria C4

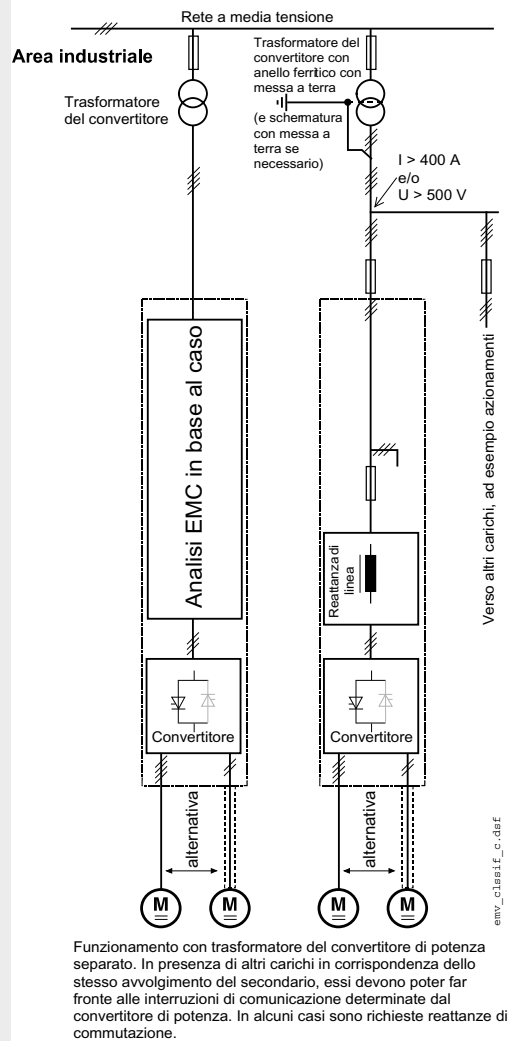

Classificazione

La seguente panoramica utilizza la terminologia e indica gli interventi richiesti in conformità alla Norma di prodotto

EN 61800-3

Per i convertitori DCS800, i valori limite per le interferenze emesse sono rispettati purché vengano eseguiti gli interventi indicati. PDS di categoria C2 (in passato distribuzione ristretta in primo ambiente) è intesa per essere installata ed avviata solo da un professionista (persona od organizzazione con le necessarie competenze nell'installazione e/o avviamento di PDS incluso gli aspetti relativi alle EMC).

Per i convertitori di potenza privi di componenti aggiuntivi, è applicabile la seguente avvertenza:

Questo è un prodotto di categoria C2 ai sensi delle IEC 61800-3:2004. Il prodotto può causare interferenze radio in aree residenziali; in tal caso possono essere richiesti accorgimenti supplementari.

Questo schema riassuntivo non illustra l'alimentazione di campo. Per quanto riguarda i cavi di corrente di campo, si applicano le stesse norme che si utilizzano per i cavi del circuito dell'indotto.

Legenda

- Cavo schermato
- Cavo non schermato con limitazione

Assegnazioni funzioni standard per I morsetti

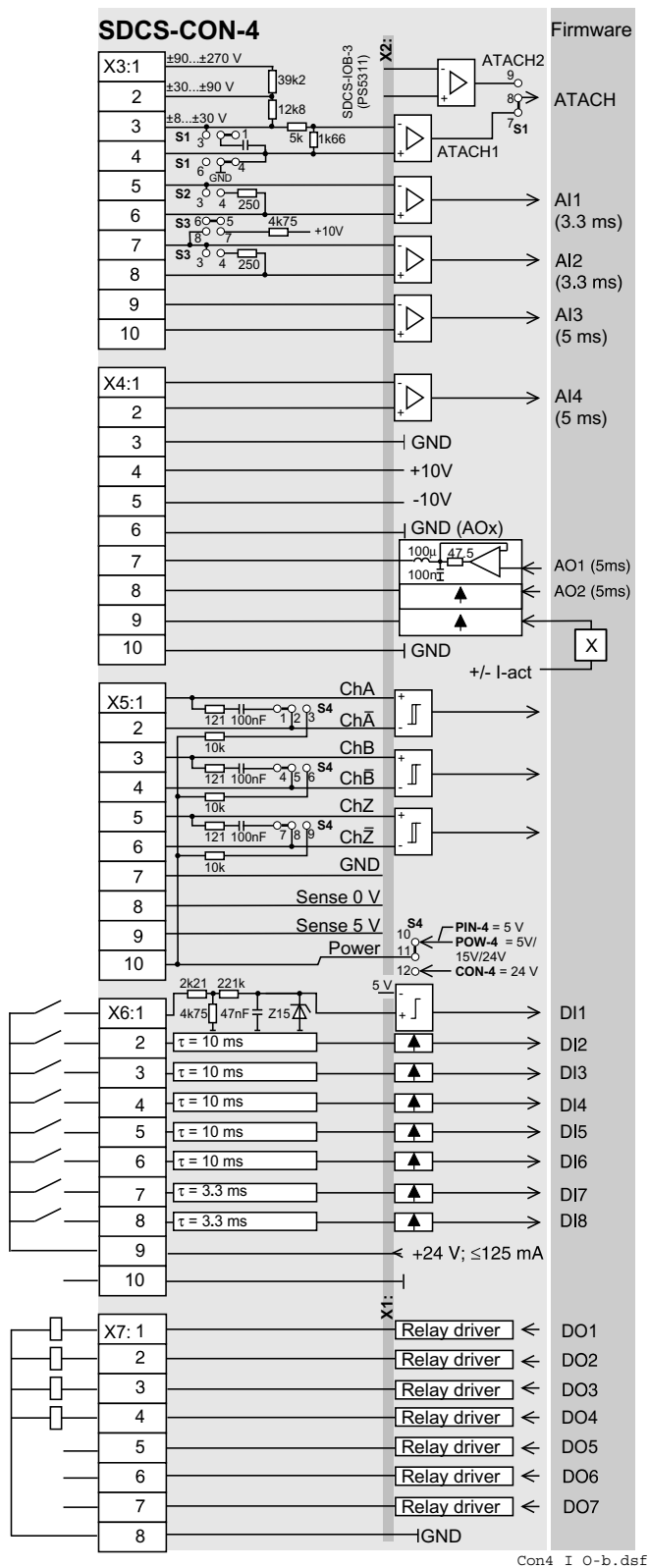

Risoluzione [bit]	Valori Input/ Output Hardware	Regolabile da	Scala	Note
15 + sign	±90...±270 V ±30...±90 V ±8...±30 V	① Firmware	±15 V	
15 + sign	-10...0...+10 V	Firmware	±15 V	
15 + sign	-10...0...+10 V	Firmware	±15 V	
15 + sign	-10...0...+10 V	Firmware	±15 V	
15 + sign	-10...0...+10 V	Firmware	±15V	
			Potenza	
	+10 V		≤ 5 mA	for ext. use e.g. refer. pot.
	-10 V		≤ 5 mA	
11 + sign	-10...0...+10 V	Firmware	≤ 5 mA	
11 + sign	-10...0...+10 V	Firmware	≤ 5 mA	
	-10...0...+10 V	Firmware+ Hardware	≤ 5 mA	8 V -> min. of 325% of [99.03] or 230% of [4.05]

Alimentazione encoder	Note
	Ingressi non isolati Impedenza = 120 Ω, se selezionato Frequenza max. ≤ 300 kHz
5 V 24 V	≤ 250 mA ≤ 250 mA
	Rilevare le linee GND e alimentazione in relazione a un calo di tensione co retto sul cavo (solo se si utilizza l'encoder da 5V)

Valore d'ingresso	Segnale definite da	Note
0...7.3 V 7.5...50 V	Firmware	-> "0" status -> "1" status

Valore d'uscita	Segnale definite da	Note
50 * mA 22 V at no load	Firmware	Corrente limite per tutte le 7 uscite = 160 mA Non applicare tensioni inverse!

* protetto al cortocircuito
① il guadagno può essere modificato in 15 gradini tra 1 e 4 per mezzo di parametro software

Esempio di collegamento

Configurazione azionamento con convertitori D1 ... D4 ad eccitatrice di campo , Interna Terminal selection according FACTORY macro (default)

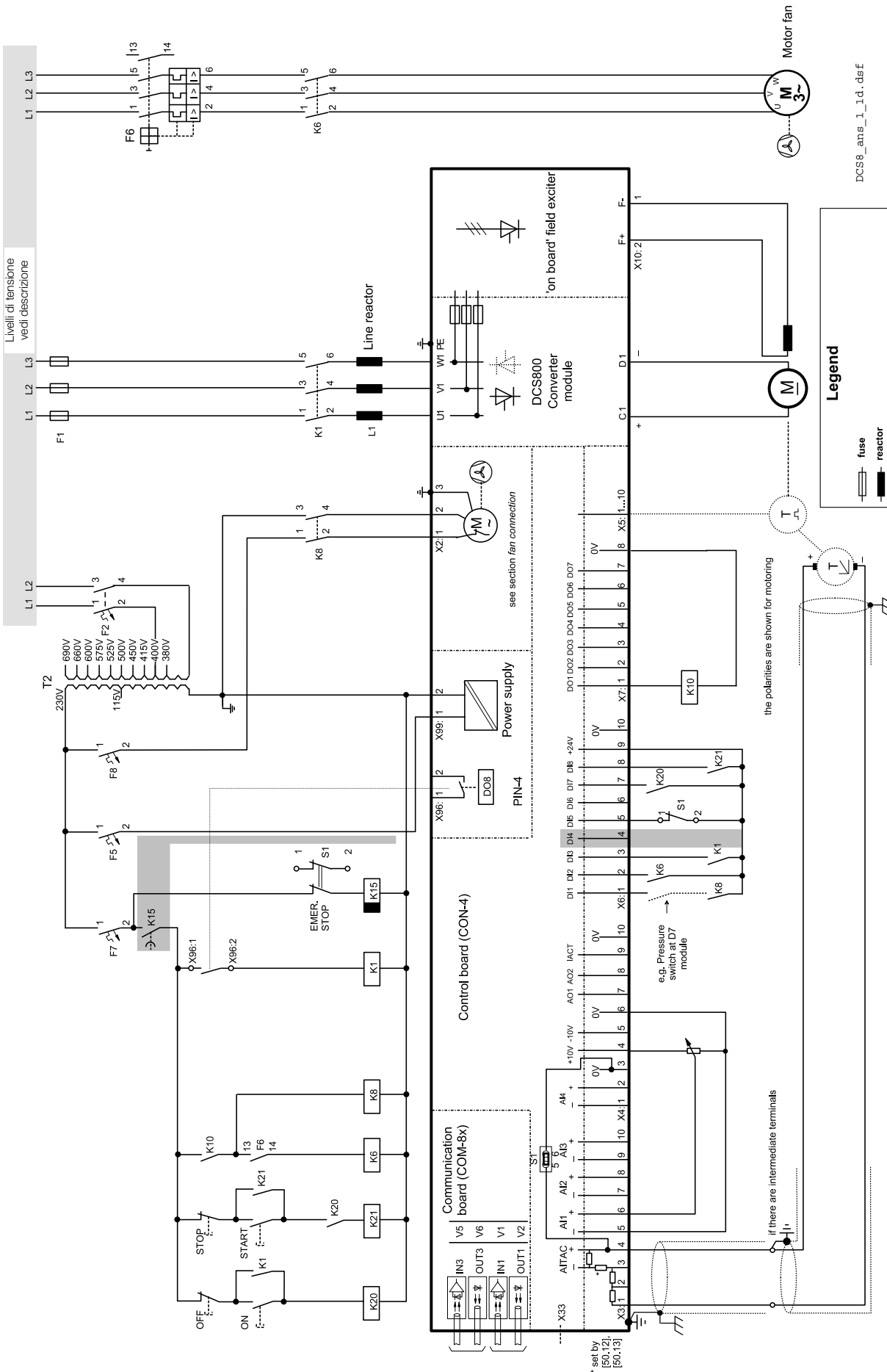

per ulteriori informazioni vedi pagina seguente

Controllo di START, STOP e E-STOP

La logica a relè può essere divisa in tre parti:

a: Generazione dei comandi di ON/OFF e START/STOP: I comandi rappresentati da K20 e K21 (relè di interfaccia blocco) possono essere generati da un PLC e trasferiti ai morsetti del convertitore mediante relè con isolamento galvanico o direttamente tramite segnali a 24V. Non è necessario utilizzare segnali cablati. Questi comandi possono essere trasferiti anche mediante collegamento seriale. E' possibile anche una soluzione mista selezionando differenti possibilità per l'uno o l'altro segnale (vedi gruppo parametri 11).

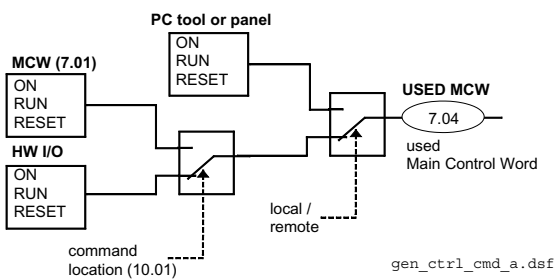

b: Generazione di segnali di controllo e monitoraggio: Il contattore di potenza K1 per il circuito d'indotto è controllato da un contatto a secco (DO8) montato sulla SDCS-PIN-4, lo stato dei ventilatori può essere monitorato per mezzo dei segnali di riconoscimento ventilatori: MotFanAck (10.06) e ConvFanAck (10.20).

c: Modalità di arresto OFF2, OFF3: In aggiunta a ON/OFF e START/STOP l'azionamento è equipaggiato con due funzioni di stop aggiuntive: OFF2 e OFF3 in accordo allo standard Profibus. OFF3 è una funzione di stop selezionabile (arresto in rampa, in limitazione di corrente, in frenatura dinamica...) per garantire un arresto in categoria 1. Questa funzione dovrebbe essere collegata al pulsante E-STOP con nessun tempo di ritardo. In caso di scelta di arresto in rampa il relè temporizzato K15 deve essere tarato con un tempo più lungo di EStopRamp (22.04). Per la scelta COAST l'azionamento apre il contattore principale immediatamente.

OFF2 riduce la corrente a zero il più rapidamente possibile e predispose il drive per aprire il contattore principale o togliere l'alimentazione principale. Per un motore CC il tempo di azzeramento della corrente CC è inferiore a 20 ms. Questa funzione dovrebbe essere collegata a tutti i segnali e funzioni di sicurezza che aprono il contattore principale. Questa funzione è importante per gli azionamenti a 4-quadranti. Non aprire il contattore principale durante la fase di corrente rigenerativa.

- La sequenza corretta è
1. Azzerare la corrente rigenerativa
 2. Poi aprire il contattore principale

In caso di selezione di E-STOP, l'informazione è trasferita al convertitore tramite l'ingresso digitale 5. In caso di (arresto con funzione di rampa o in limitazione di corrente) il convertitore decelererà il motore e poi aprirà il contattore principale. Se il convertitore non riesce ad arrestare l'azionamento entro il limite temporale impostato da K15, deve dare il comando di azzeramento della corrente tramite K16. Dopo che il tempo impostato per K16 è trascorso il contattore principale viene aperto indipendentemente dallo stato del drive.

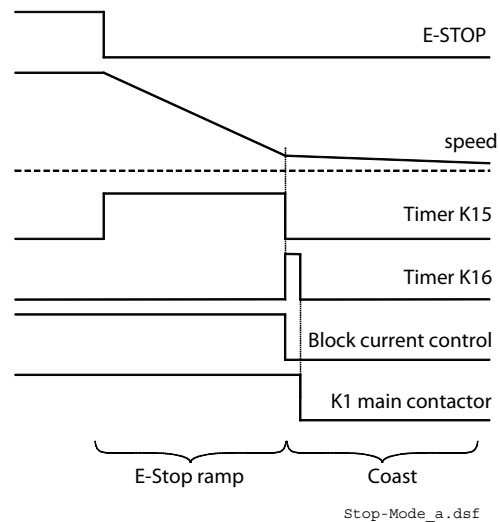
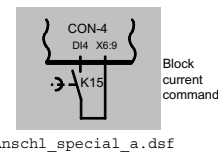
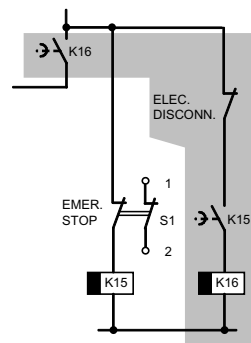

E-Stop reaction

Ventole di raffreddamento

Tipi di ventole per i DCS800

Unità DCS	Modello	Configurazione	Ventole
DCS800-S01-0020-04/05 DCS800-S02-0025-04/05	D1	-	no fan
DCS800-S0x-0045-04/05... DCS800-S0x-0140-04/05	D1	1	115 or 230 VAC
DCS800-S0x-0180-04/05... DCS800-S0x-0260-04/05	D2	1	115 or 230 VAC
DCS800-S0x-0315-04/05... DCS800-S0x-0350-04/05	D3	1	115 or 230 VAC
DCS800-S0x-0405-04/05... DCS800-S0x-0520-04/05	D3	2	115 or 230 VAC
DCS800-S0x-0610-04/05... DCS800-S0x-0820-04/05	D4	3	230 VAC
DCS800-S0x-0610-04/05... DCS800-S0x-0820-04/05	D4 Pluscode S171	3	115 VAC
DCS800-S0x-0900-04/05... DCS800-S0x-1000-04/05	D4	3	230 VAC
DCS800-S0x-0900-04/05... DCS800-S0x-1000-04/05	D4 Pluscode S171	3	115 VAC

Collegamento delle ventole per i DCS800

Morsetti in cima all'involucro del convertitore

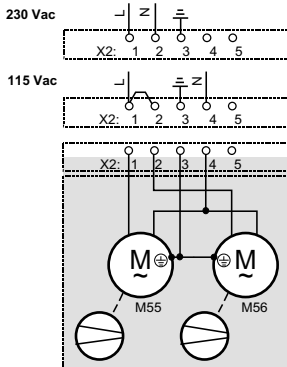

Configurazione 1
D1-D3

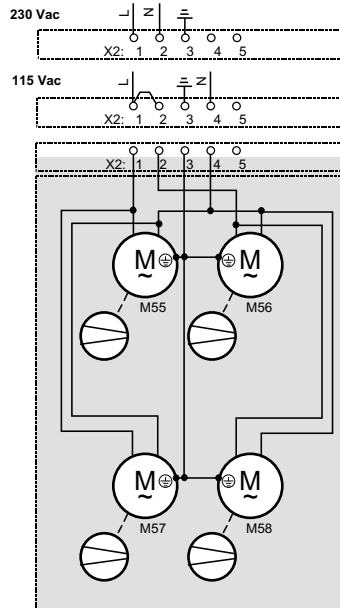

Configurazione 2
D3

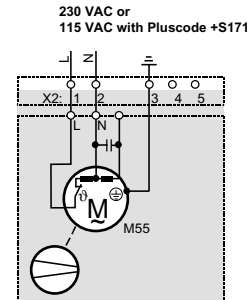

Configurazione 3
D4

DCS8 fan conn D1-D4.dsf

Posizioni terminali sul convertitore

SDCS-CON-4 Steckeranschlüsse

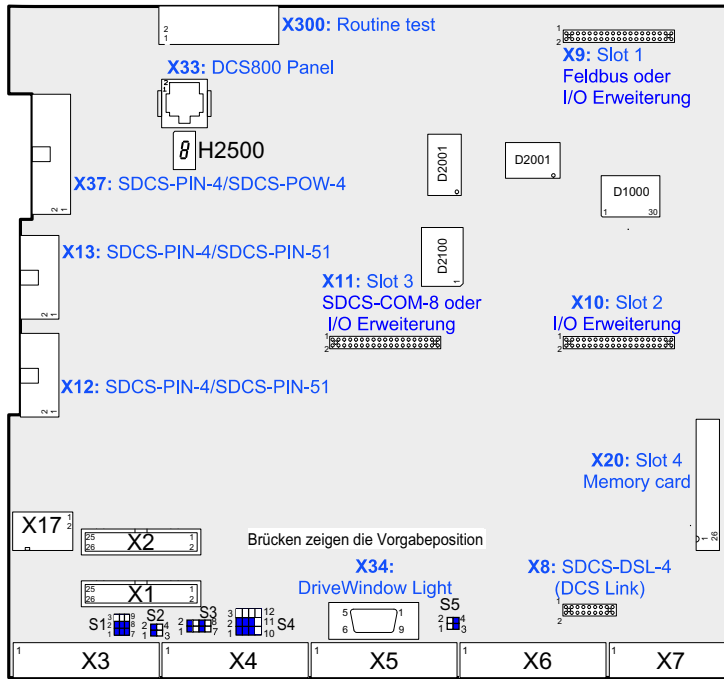

DCS800 Modul ANSCHLUSSKLEMMEN

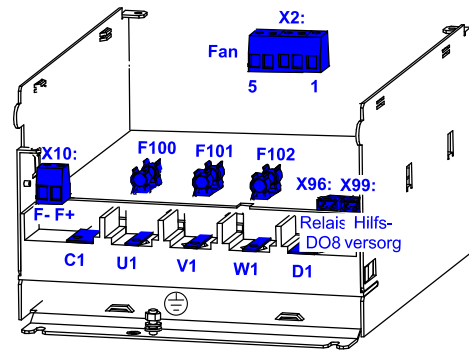

DCS800 Zubehör

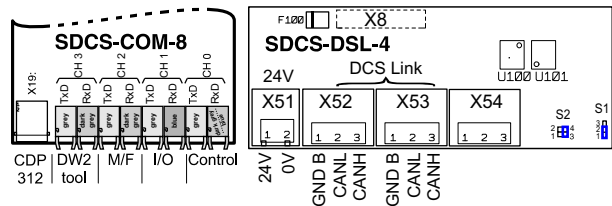

SDCS-CON-4: KLEMMENZUORDNUNG

X3 Tacho and AI		X4 AI and AO		X5 Encoder		X6 DI		X7 DO	
1	2	1	2	1	2	1	2	1	2
90...270V	30...90V	AI1-	AI1+	+A	-A	DI1	DI2	DO1	DO2
8...30V	0V	AI2-	AI2+	+B	-B	DI3	DI4	DO3	DO4
		AI3-	AI3+	+Z	-Z	DI5	DI6	DO5	DO6
		AI4-	AI4+	GND	GND	DI7	DI8	DO7	DO8
		AO1	AO2	Sense GND	Sense Us	+24	0V		
		AO3 (fact)							

DCS800 terminal alloc_a.dsff

Macro Name	Haupt-schütz	ON / OFF Start/Stop	DI Funktion	Kommentar	DI5 --> ESTOP DI6 --> Reset
Standard					
	AC	Static	Jog1 --> DI1 Jog2 --> DI2 Ext Fault --> DI 3 Ext Alarm --> DI4	Hardware I/O Steuerung	x
2-wire DC cont. US					
	DC	Static	Jog1 --> DI1 Jog2 --> DI2 Ext Fault --> DI 3 Main Cont Ack --> DI4	Hardware I/O Steuerung	x
3-wire DC cont. US					
	DC	Pulse	Fix speed1 --> DI1 Ext Fault --> DI 3 Main Cont Ack --> DI4	Hardware I/O Steuerung	x
3-wire Standard					
	AC	Pulse	Fix speed1 --> DI1 Ext Fault --> DI 3 Ext Alarm --> DI4	Hardware I/O Steuerung	x
Torque limit					
	AC	Static	Jog1 --> DI1 Jog2 --> DI2 Ext Fault --> DI 3 Ext Alarm --> DI4	Hardware I/O Steuerung + Torque limit	x
Manual / Const					
	AC	Pulse	Jog1 --> DI1 Jog2 --> DI2 Direction --> DI 3 SpC - KP, KI --> DI4	Hardware I/O Steuerung	x
Hand / Auto					
	AC	Static	Control select --> DI2 Reference select --> DI2 Direction select --> DI 3	Hardware I/O Steuerung oder Feldbussteuerung	x
Hand / Mot Pot					
	AC	Pulse	Motor pot up --> DI1 Motor pot down --> DI2 Direction select --> DI 3 Reference select --> DI4	Hardware I/O Steuerung Sollwert durch Hardware oder Motorpotentiometer	x
Motor Pot					
	AC	Static	Direction select --> DI 1 Motor pot up --> DI2 Motor pot down --> DI3 Motor pot minimum --> DI4	Hardware I/O Steuerung Sollwert durch Motor potentiometer	x
Torque Ctrl					
	AC	Static	OFF2 (coast stop) --> DI1 Torque select --> DI2 Ext Fault --> DI 3	Hardware I/O Steuerung Drehzahlregelungl oder Momentensollwert	x

Abilitare una macro

Usare il di **[DCS800Wizard] 2. Macro assistant** di DriveWindow Light o

Usare il browser parametro, o tramite il pannello di controllo, DriveWindow, o DriveWindow Light.

usa i seguenti parametri:
ApplMacro (99.08) = macro scegliere
Apprestore (99.07) = YES = eseguire il comando
MacroSel (8.10) = eseguire il comando

NOTA
 Funzioni ed ingressi definiti dalla macro possono essere cambiati piu avanti senza restrizioni

NOTA
 Schema macro vedi pagina 93 ...

Istruzioni per la sicurezza



per convertitori in c.c. DCS / DCF / DCR

(secondo: Direttiva Bassa Tensione 73/23/CEE)

1. Prescrizioni generali

Convertitori in c.c. relativo al loro grado di protezione possono avere durante il funzionamento parti sotto tensione non isolati, parti mobili o rotanti e superfici con temperature elevati.

Nei casi di rimozione non ammessa di parti dell' involuoco necessari per la protezione, di utilizzo improprio e installazione e/o impiego non corretto sussiste grave pericolo per persone o cose.

Ulteriori informazioni sono contenute nei rispettivi manuali.

Tutti i lavori di trasporto, installazione, messa in funzione e manutenzione devono essere eseguiti da personale qualificato ed autorizzato (osservare le norme IEC 364, CENELEC HD 384 o DIN VDE 0100 e IEC 664 o DIN VDE 0110 e norme antiinfortunistiche nazionali).

Negli avvisi di sicurezza come personale qualificato, si intendono tecnici specializzati all' installazione, il montaggio, la messa in funzione ed il funzionamento del apparato, con specifiche conoscenze e qualifiche.

2. Uso appropriato

I convertitori in c.c. sono componenti destinati ad essere incorporati in impianti o macchine.

Se il convertitore viene integrato in una macchina, questo non potrà essere messo in servizio affinché la macchina stessa non risponderà ai requisiti della Direttiva 89/392/CEE (Direttiva Macchine); La norma EN 60204 deve essere rispettata.

La messa in servizio è concessa solo se la Direttiva EMC (89/336/CEE) viene rispettata.

I convertitori in c.c. sono conformi alle esigenze della Direttiva Bassa Tensione 73/23/CEE. Per i convertitori in c.c. vengono applicate le norme armonizzate della serie prEN 50178/DIN VDE 0160 in combinazione con le norme EN 60439-1/DIN VDE 0660 parte 500 e EN 60146/DIN VDE 0558.

Dati tecnici e indicazioni per l' allacciamento sono riportati sia sulla targa d' identificazione che nella documentazione tecnica e devono essere rispettati in ogni caso.

3. Trasporto, Immagazzinamento

Gli avvisi per il trasporto, l' immagazzinamento e la manipolazione devono essere osservati scrupolosamente.

Le condizioni climatiche secondo prEN 50178 devono essere rispettate.

4. Montaggio

Per il montaggio ed il raffreddamento degli apparecchi devono essere rispettate le prescrizioni contenute nella documentazione.

I convertitori in c.c. devono essere protetti da condizioni di lavoro inammissibili. Durante il trasporto e la manipolazione si deve fare particolare attenzione a non piegare componenti e/o a modificare distanze d' isolamento. Evitare il contatto con altri componenti elettronici o contatti elettrici.

I convertitori in c.c. contengono componenti elettronici sensibili a scariche elettrostatiche, che possono essere danneggiati facilmente se maneggiati in modo non corretto. Componenti elettrici non devono essere danneggiati o distrutti meccanicamente. (eventualmente potrebbe sussistere pericolo per la salute!).

5. Collegamento elettrico

In caso di lavori sul convertitore di frequenza sotto tensione devono essere osservate le norme antiinfortunistiche nazionali in vigore.

L' installazione elettrica deve essere eseguita secondo le norme vigenti (p.es. sezione cavi, dispositivi di protezione contro sovracorrenti, collegamento circuito di protezione equipotenziale). Ulteriori avvisi sono contenuti nella documentazione.

Indicazioni per eventuali accorgimenti antidisturbo - come schermatura, messa a terra, disposizione di filtri e posa di condutture - sono contenute nella documentazione tecnica. Queste indicazioni devono essere osservate anche in caso di convertitori muniti di marchio CE. L' adempimento dei limiti richiesti dalla legislazione EMC è di responsabilità del costruttore dell' impianto o della macchina.

6. Funzionamento

Impianti dotati di convertitori in c.c. devono essere equipaggiati eventualmente con impianti di sorveglianza o protezione aggiuntivi conformi alle vigenti norme di sicurezza.

Sono ammesse modifiche ai convertitori in c.c. tramite il software di gestione.

Dopo aver staccato il convertitore dalla rete di alimentazione non si devono toccare subito parti sotto tensione e morsetti di collegamento a causa di condensatori ancora carichi. A questo proposito devono essere osservati i relativi indicazioni di avvertimento presenti sul involuoco del convertitore.

Durante il funzionamento coperchi e porte del involuoco devono rimanere chiusi.

7. Manutenzione

Le prescrizioni del costruttore devono essere rispettati.

Questi avvisi di sicurezza devono essere conservati!

Installa i DCS800 PC tools sul Tuo computer

Dopo aver inserito il DCS800 CD tutti i programmi e la documentazione necessaria per lavorare con il DCS800 saranno automaticamente installati.

Questo include:

1. DriveWindow Light per parametrizzazione, messa in servizio e service
2. Hitachi FDT 2.2 per caricamento firmware
3. Installazione CD del DCS800 Drive per es. DWL Wizard, documentazione ABB
4. CoDeSys per programmi applicativi 61131

Attenzione:

Se non vuoi installare un certo programma devi solamente saltarlo usando Cancel all'inizio del programma wizard.



Se l'installazione non parte automaticamente:

- Vai a Start/Run cerca sul CD setup.exe. Ora fai partire l'installazione confermando con OK
- Si consiglia l'installazione compatta per DriveWindow Light + Commissioning Wizard + DriveWindow Light AP

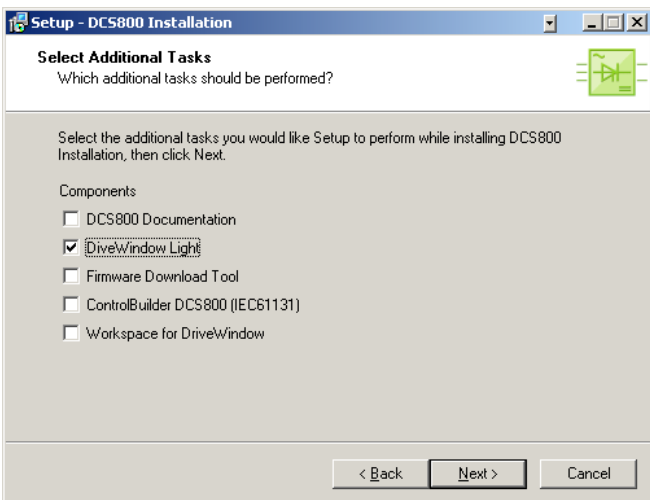

Steps per collegare il Drive al PC

- La documentazione può essere trovata in **C:\ABB\DCS800\Docu**
- Rimuovi il pannello dal modulo convertitore



Rimuovi il Pannello di Controllo Del DCS800, se presente. Premere i blocchi per rimuovere il coperchio



Collega il drive (X34) alla COM port del tuo PC

- Dai lo start al PC tool DriveWindow Light
Controlla il set di comunicazione della tua COM port

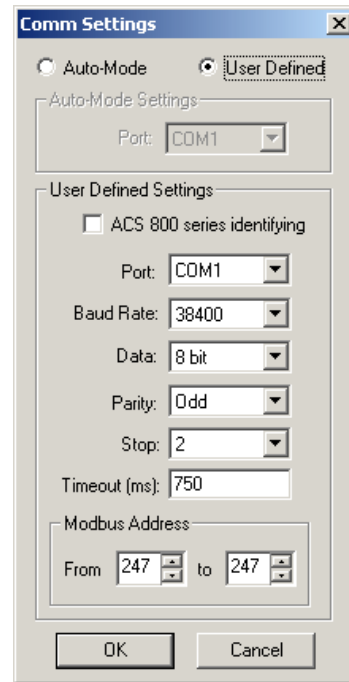

Se usi l'adattatore USB a COM port controlla la COM port attiva abilitata dalla USB
Start=> Setting => Control Panel => System => Hardware => Device manager.

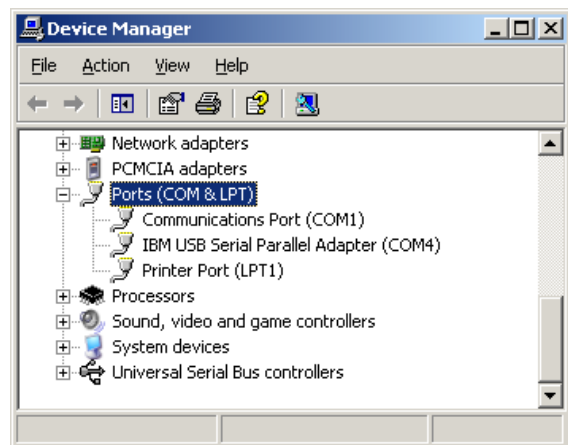

L'indirizzo COM dell'interfaccia USB può cambiare dopo la prossima procedura di boot o dopo aver scollegato e ricollegato l'interfaccia USB.

Note:

PCMCIA to COM Port provide a stable and faster drive interface.

L'utilizzo del DriveWindow Light o del DCS800 Panel Wizard continua col capitolo Messa in Servizio in questo manuale.

Per la messa in servizio con DriveWindow trovi la descrizione nel manuale firmware del DCS800.

Messa in servizio



Pericolo! Alta tensione: questo simbolo indica la presenza di alta tensione che può provocare lesioni alle persone e/o Danni alle apparecchiature. Il testo accanto al simbolo illustra eventuali provvedimenti per evitare tale pericolo.



Avvertenza generale: questo simbolo indica un pericolo, non connesso all'elettricità, che può provocare lesioni gravi o mortali alle persone e/o danni alle apparecchiature. Il testo accanto al simbolo illustra eventuali provvedimenti per evitare tale pericolo.



Avvertenza – scarica elettrostatica: questo simbolo indica la presenza di scariche elettrostatiche che possono provocare danni alle apparecchiature. Il testo accanto al simbolo illustra eventuali provvedimenti per evitare tale pericolo.

NEC protezione sovraccarico motore

Il DCS800 fornisce una protezione sovraccarico motore alla stato solido in accordo con il NEC. La protezione di sovraccarico (ad esempio un livello di protezione in percentuale della corrente di pieno carico del motore) può essere tarata dai parametri del gruppo 31 e gruppo 99.

Le istruzioni si trovano ne capitolo *Motor thermal model del DCS800 Firmware manual*.

Istruzioni generali

- Questa breve routine di messa in servizio si riferisce allo schema di collegamento contenuto nel Capitolo 5 di questa pubblicazione.
- Istruzioni per la sicurezza – si veda il capitolo 6 di questa pubblicazione.
- Raccomandazioni per tensioni di campo e motore – si veda il Catalogo tecnico.
- In conformità alle norme DIN57 100 Parte 727 / VDE 0100 Parte 727, occorre prendere precauzioni per consentire lo spegnimento dell'azionamento in caso di pericolo. A tal fine non sono sufficienti gli input digitali dell'unità o il pannello di controllo!

Operazioni preliminari

- Controllare l'integrità dell'unità!
- Installare l'unità ed eseguire il cablaggio
- Controllare che il valore nominale e il livello della tensione di alimentazione siano corretti per sistemi elettronici e ventilazione
- Controllare che il valore nominale e il livello della tensione di alimentazione siano corretti per il convertitore d'armatura.
- Controllare che il valore nominale e il livello della tensione di alimentazione siano corretti per l'alimentatore di campo
- Controllare che cablaggio / sezioni, ecc. siano corretti
- EMERGENCY STOP funziona correttamente ?
- COAST STOP funziona correttamente ?

Commissioning DriveWindow Light

Attiva il wizard nel DriveWindow Light:

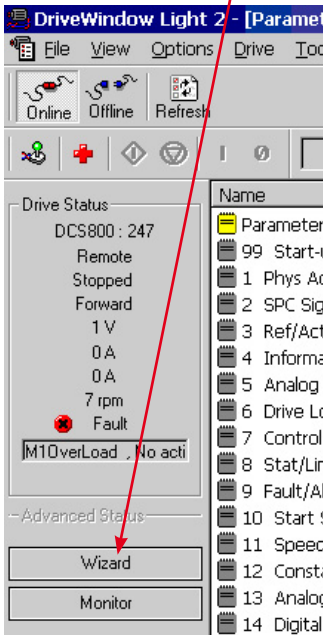

Per la messa in servizio base premere il pulsante Start o scegli l'assistente specifico:

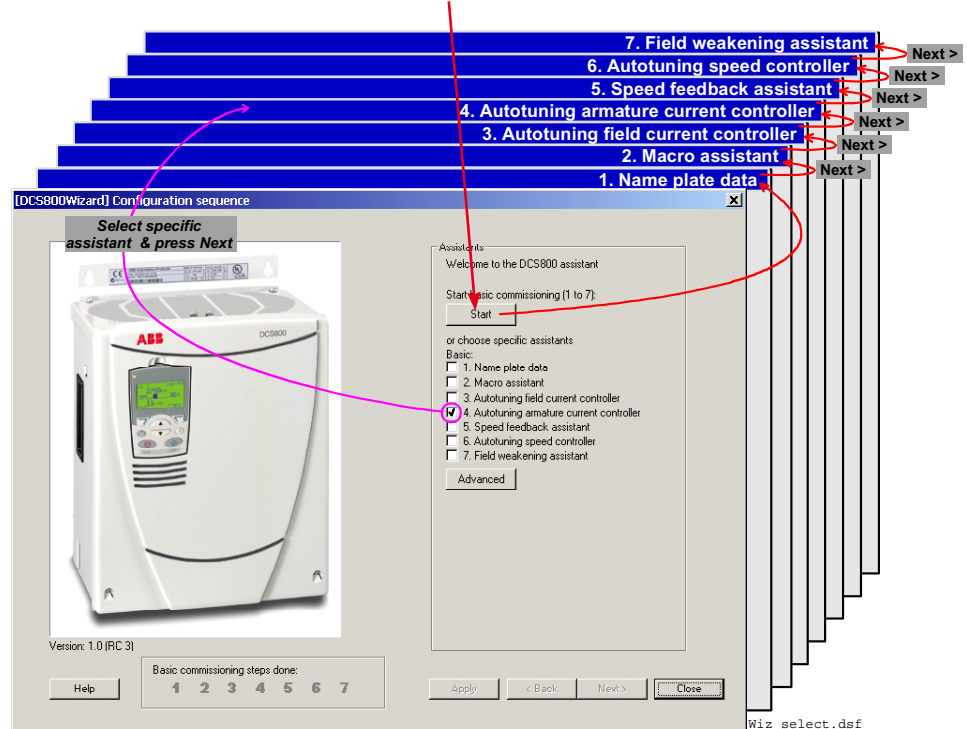

Per maggiori informazioni sul wizard, parametri, guasti e allarmi premere il pulsante Help!

DCS800 Control Panel

La seguente tabella elenca le funzioni dei pulsanti e le visualizzazioni del DCS800 Control Panel (DCS CP).

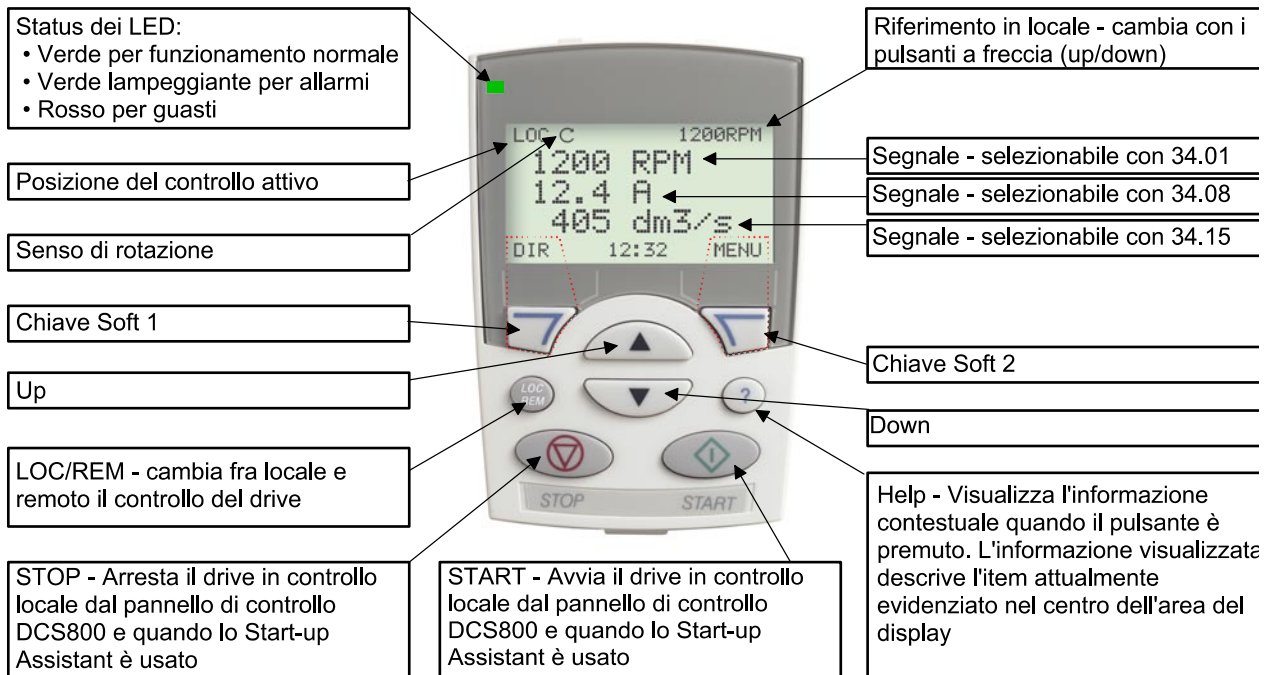

DCS800 QG pan ov_b.dsf

Con USISel (16.09) è possibile limitare il quantitativo di parametri visualizzati !

Caratteristiche generali del display

Le seguenti modalità sono disponibili nel MAIN MENU:

1. Modalità parametri
2. Modalità Start-up assistant
 - a. Dati di targa
 - b. Assistente macro
 - c. Autotaratura regolatore corrente di campo
 - d. Autotaratura corrente d'armatura
 - e. Assistente retroazione di velocità (Taratura fine della tachimetrica non è disponibile)
 - f. Autotaratura regolatore di velocità
 - g. Assistente indebolimento di campo (usato solamente quando la vel.max. è maggiore della vel. base)
3. Modalità macro (attualmente non usata)
4. Modalità parametri modificati (confronta con quelli di default e visualizza quelli modificati)
5. Modalità registro guasti (Visualizza storia del guasto)
6. Modalità impostazione orologio
7. Modalità backup parametri
 - Copia il set parametri attivi dal drive al DCS800 Control Panel (solo in modo locale)
 - Copia il set parametri dal DCS800 Control Panel al drive (solo in modo locale)
8. Modalità impostazione I/O (attualmente non usato)

Parameters entered by assistant

99.02	Motor 1 nominal Voltage
99.03	Motor 1 nominal current
99.04	Motor 1 base speed
20.01	Motor 1 minimum speed
20.02	Motor 1 maximum speed
99.11	Motor 1 nominal field current
30.09	Armature over current level
30.16	Motor 1 over speed
99.10	Nominal mains voltage
99.12	Motor 1 used fex type
20.05	Torque maximum
20.06	Torque minimum
20.12	Motor 1 current limit bridge 1
20.13	Motor 1 current limit bridge 2
50.04	Motor 1 encoder pulse number, if selected
50.02	Motor 1 encoder measured mode, if selected
50.13	Motor 1 tacho volt, only DWL
50.12	Motor 1 tacho adapt, only DWL
20.03	Zero speed limit
22.01	Acceleration time 1
22.02	Deceleration time 1
30.12	Motor 1 field minimum trip
44.01	Field control mode



Características de serie

- compacto
- alta capacidad de potencia
- funcionamiento sencillo
- asistentes prácticos, p. ej. puesta en funcionamiento y ajuste automático
- escalable para todas las aplicaciones
- programación libre mediante el IEC61131-PLC integrado

español

DCS800 DC Drives

Datos técnicos

Tensión aliment. de red	230...1,200 V, +/-10%, 3~
Frecuencia	50...60 Hz, +/-5 Hz
Aliment. comp. electrónicos	115...230 V, -15% / +10%, 1~
Intensidad de salida	CC20...5,200 A
Capacidad de sobrecarga	200%

Condiciones ambientales

Temp. ambiente	0° ... +40° C 40° ... 55° C con reducción
Temp. de almacenamiento	-40° ... +55° C
Temp. de transporte	-40° ... +70° C
Humedad relativa	5 ... 95%, sin condensación (máx. 50% entre 0°...5° C)
Grado de contaminación	Clase 2
Clase de protección	IP 00
Altitud	< 1,000 m sobre el nivel del mar: intensidad nominal > 1.000 m sobre el nivel del mar: con reducción

E/S

Entradas digitales: 8 estándar, hasta 14 opcionales
Salidas digitales: 8 estándar, hasta 12 opcionales
Entradas analógicas: 4 estándar +/-10 V; 0/2...10 V, hasta 8 opcionales +/- 20 mA; 0/4...20 mA
Salidas analógicas: 3 estándar (1x Iact) +/-10 V; 0/2...10 V, hasta 7 opcionales -20 mA; 0/4...20 mA

Herramientas para PC

DriveWindow Light: se incluye gratuitamente con cada convertidor, conexión PC RS232 estándar
DriveWindow: conexión óptica en tiempo real
ControlBuilder DCS800: herramienta de programación IEC61131
DriveSize: dimensionado del convertidor y del motor

Mantenimiento / Diagnóstico

Diagnóstico remoto a través de Internet desde cualquier ordenador en todo mundo
 • con navegador / explorador Web
 • o con pleno control del convert. con DriveWindow a través de OPC

Homologaciones



Programación adaptativa

bloques de funciones predefinidos específicos del convertidor, p. ej.
 • Regulador de proceso gratuito (regulador PI)
 • Operaciones digitales y de E/S
 Con panel de control o herramienta de PC sin necesidad de hardware adicional

Realimentación de velocidad

EMF
 Tacómetro analógico
 Generador de pulsos
 Posibilidad de un 2.º generador de pulsos (RTAC)

Comunicación

Comunicación en serie
 • Ethernet • Profibus
 • CANopen • DeviceNet
 • ControlNet • DDCS
 • Modbus
 • CS31 • AF100
 • Selma2
 habilitado para Industrial IT®

DCSLink de punto a punto

• Hasta 800 kilobaudios, < 2,5 ms
 • Maestro/Esclavo
 • Convertidor de inducido/de excitación
 • Datos de libre selección

Soluciones de alta intensidad

• A 12 pulsos hasta 20.000 A, en serie y paralelo
 • Configuración en paralelo y secuencial
 • hasta 1.500 V

Protecciones

Monitorización de realimentación de velocidad • Temperatura • Sobrecarga • Velocidad excesiva • Bloqueo del motor • Sobreintensidad del motor • Sobretensión del motor • Sobreintensidad de campo • Sobretensión de campo • Intensidad de campo mínima • Velocidad cero • Rizado de corriente inducida • Sobretensión y subtensión de red

IEC 61131-PLC integrado

• Herramienta de programación estándar abierta ControlBuilder DCS800
 • Soporte en los cinco idiomas de la CEI
 • Bloques de funciones específicas del convertidor
 • Almacenamiento del programa y de la fuente en la tarjeta de memoria
 • Forzado y depuración en línea

Especificaciones de intensidad, dimensiones

Tamaño unidad	2-Q Intensidad nominal DCS800-01 I _{DC} [A]	4-Q Intensidad nominal DCS800-02 I _{DC} [A]	Tensión de alimentación [V _{AC}]							Intensidad máx. excitación interna [A _{DC}]	Dimensiones	
			400	525	600	690	800	990	1200		al. x an. x pr. [mm]	al. x an. x pr. [pulg.]
D1	20	25	●	●					6	370 x 270 x 200	14.56 x 10.65 x 7.90	
	45	50	●	●								
	65	75	●	●								
	90	100	●	●								
	125	140	●	●								
D2	180	200	●	●				15	370 x 270 x 270	14.56 x 10.65 x 10.65		
	230	260	●	●								
D3	315	350	●	●	● ³⁾			20	459 x 270 x 310	18.07 x 10.65 x 12.25		
	405	450	●	●								
	470	520	●	●								
D4	610	680	●	●	● ³⁾			25	644 x 270 x 345	25.35 x 10.65 x 13.60		
	740	820	●	●								
	900	1000	●	●								
D5	900	900	●	●	●	●		25	1050 x 510 x 410	41.35 x 20.10 x 16.15		
	1200	1200	●	●								
	1500	1500	●	●	●	●						
	2000	2000	●	●	● ¹⁾	● ¹⁾						
D6	1900	1900		●	●	●	●	control excit. externo 35A, 1~/3~ 50/60A, 1~ 520A, 3~	1750 x 460 x 410	68.90 x 18.15 x 16.15		
	2050	2050		●	●	●	●					
	2500	2500	●	●	●	●	●					
	3000	3000	●	●	●	●	●					
D7	2050	2050		●	●	●	●	control excit. externo 35A, 1~/3~ 50/60A, 1~ 520A, 3~	1750 x 760 x 570	68.90 x 29.95 x 22.45		
	2600	2600		●	●	●	●					
	3300	3300	●	●	●	●	●					
	4000	4000	●	●	●	●	●					
	4800	4800		●	●	●	●					
	5200	5200	●	●								

●¹⁾ sólo disponible como convertidor 2-Q ●²⁾ previa petición ●³⁾ 600V
 2-Q -> 290 A / 590 A
 4-Q -> 320 A / 650 A

Instrucciones para el CD y de la documentación

Le agradecemos la compra del convertidor de potencia de CC y la confianza que deposita en nuestros productos.

Este folleto ha sido elaborado para garantizar su satisfacción continua con nuestro producto. El propósito de éste es proporcionarle una visión general de los datos clave del producto, las notas sobre EMC, las aplicaciones habituales, la puesta en marcha y la solución de problemas.

Si necesita más información acerca del producto, le suministramos un **CD-ROM** junto con esta documentación resumida. El CD-ROM forma parte de esta documentación y su contenido es el siguiente:

Documentación

La documentación se estructura básicamente del modo siguiente:

Catálogo técnico (3ADW000192)

Información exhaustiva para ingenieros de sistemas de convertidores de CC completos.

Manual de hardware (3ADW000194)

Información detallada, con todas las particularidades relevantes de los componentes individuales, como dimensiones del módulo, placas de componentes electrónicos, ventiladores y componentes auxiliares.

También se incluye información relativa a la instalación mecánica y eléctrica.

Manual de firmware (3ADW000193)

Información detallada que contiene todos los temas importantes acerca del firmware y el ajuste de parámetros. El manual incluye información detallada para la puesta en marcha y el mantenimiento del convertidor en su totalidad.

Asimismo, el manual incluye los códigos de fallo y alarmas e información para la solución de problemas.

Manual de servicio (3ADW000195)

Información para el mantenimiento y reparación de los convertidores.

Aplicaciones

El convertidor de CC DCS800 puede incluir software de aplicación, p. ej. para grúas o bobinadoras. En tal caso, algunos procedimientos y asistentes pueden estar bloqueados o no ser completos. Para obtener más información, consulte otros documentos y manuales (compruebe el parámetro 4.03, 83.01).

La información adicional **acerca de aplicaciones** (p. ej. 12 pulsos) y **accesorios técnicos** (p. ej. ampliación de hardware o interfases de bus de campo) se describe en manuales distintos. Véase la tabla *Manuales del convertidor DCS800*.

Requisitos del sistema para usar el CD-ROM

- Sistema operativo WINDOWS 2000, XP
- ADOBE READER 4.0 o superior (recomendamos la versión 8.0 incluida en el CD-ROM)



Si el CD-ROM no se inicia automáticamente, haga doble clic sobre el archivo **Setup.exe**.

Asistencia adicional

Además le ofrecemos asistencia adicional, puesto que sólo nos consideramos satisfechos si usted, como cliente, también lo está con nosotros y nuestros productos.

Internet

En la página principal de ABB en

www.abb.com/dc

encontrará abundante información acerca de:

- productos de CC
- asistencia técnica
- las últimas actualizaciones
- herramientas
- descargas, etc.

No dude en visitar nuestra página.

Contacto

Si necesita cualquier información adicional, póngase en contacto con su oficina **ABB Drives** más cercana o envíe un correo electrónico a:

DC-Drives@de.abb.com

Facilítenos su nombre, la dirección de su empresa y número de teléfono. Le pondremos en contacto con nuestro especialista de forma inmediata.

Notas acerca de la EMC

Encontrará información adicional en la publicación:

Guía técnica, capítulo: Instalación y configuración de un sistema de convertidor que cumpla la Directiva EMC

Los siguientes párrafos describen la selección de los componentes eléctricos conforme a las directrices de compatibilidad electromagnética (EMC).

El objetivo de las directrices EMC es, como su nombre indica, conseguir compatibilidad electromagnética con otros productos y sistemas. Las directrices aseguran que las emisiones del producto en cuestión sean lo suficientemente débiles como para no dificultar la inmunidad a interferencias de otro producto.

Dentro del contexto de las directrices EMC deben tenerse presentes dos aspectos:

- la inmunidad a interferencias del producto
- las emisiones reales del producto

Las directrices EMC esperan que durante el desarrollo de un producto se tengan en cuenta las recomendaciones para EMC; sin embargo, la EMC no puede diseñarse, sólo puede medirse cuantitativamente.

Nota sobre la conformidad EMC

El procedimiento de conformidad es responsabilidad tanto del proveedor del convertidor de potencia como del fabricante de la máquina o sistema implicado, en proporción a su parte en la ampliación del equipo eléctrico en cuestión.

Primer entorno (áreas residenciales con industria ligera) con categoría PDS C2	
No aplicable, ya que la categoría C1 (canal de ventas de distribución general) queda excluida	
No aplicable	conforme
conforme	

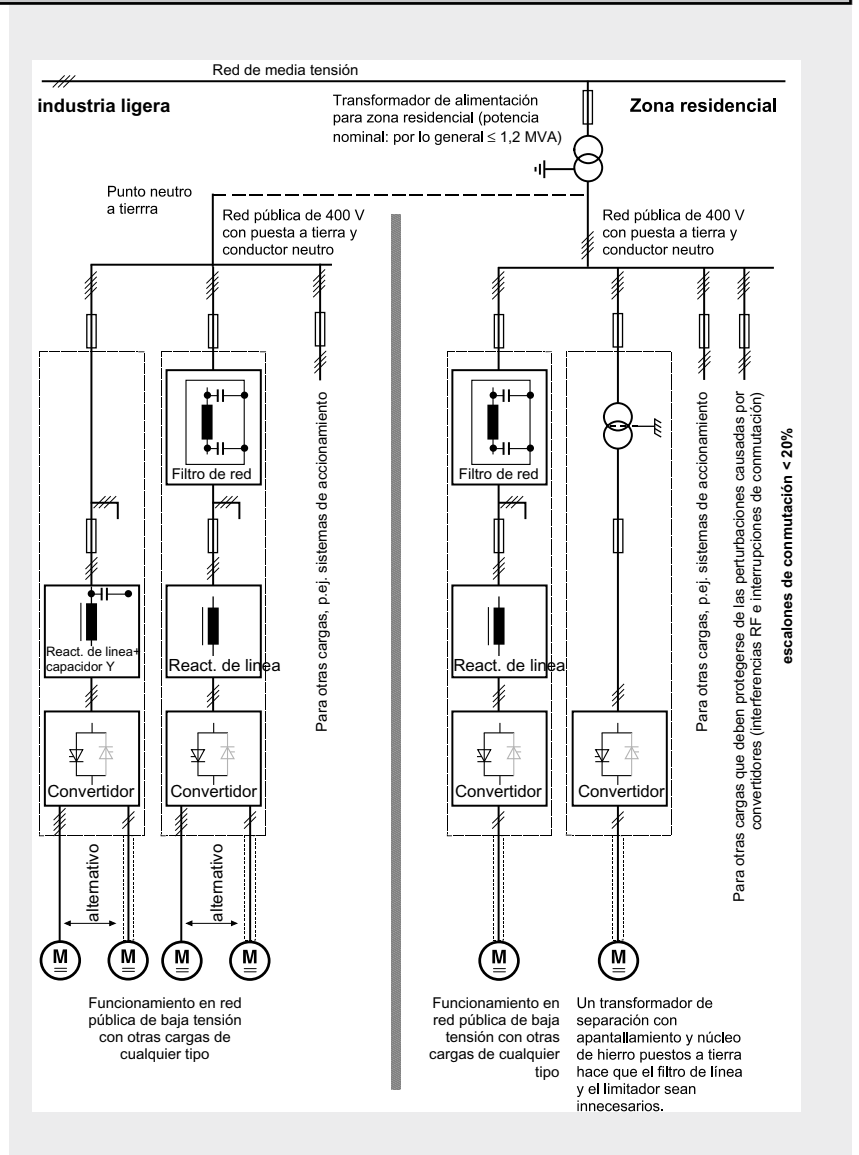
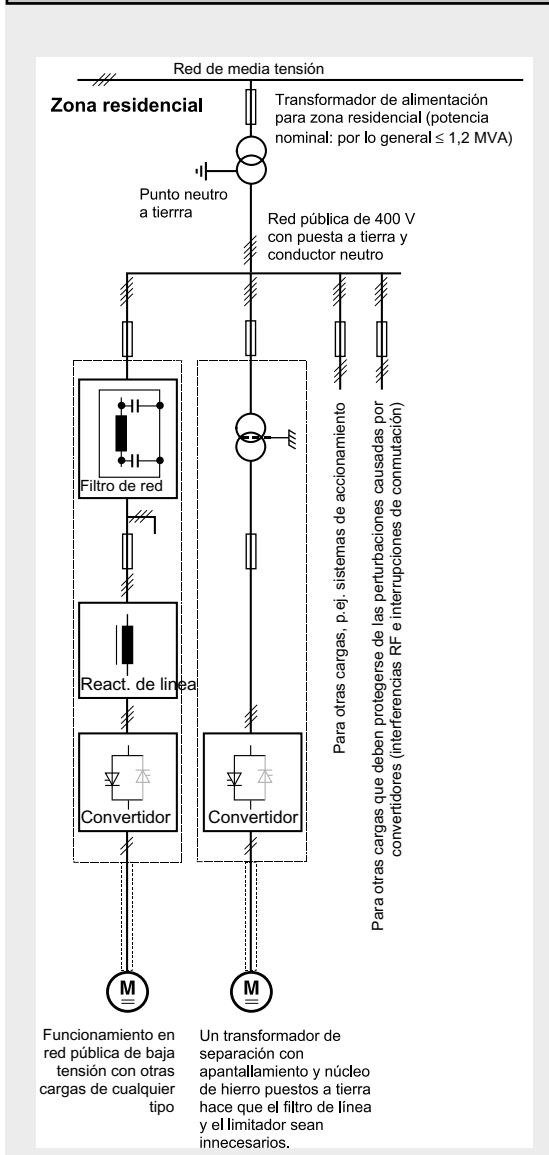

Para la conformidad con los objetivos de protección del acta alemana de EMC (EMVG) en máquinas y sistemas, deben cumplirse las siguientes normas EMC:

Norma de producto EN 61800-3

EMC para sistemas de convertidores (Power Drive System), inmunidad a interferencias y emisiones en áreas residenciales, zonas empresariales con industria ligera y en instalaciones industriales.

Esta norma debe cumplirse en la UE para satisfacer los requisitos EMC de sistemas y de máquinas

Para la emisión de interferencias se aplica lo siguiente:

EN 61000-6-3 Norma básica especializada para emisiones en la industria ligera que puede cumplirse con características especiales (filtros de red, cables de potencia apantallados) en las especificaciones nominales más bajas *(EN 50081-1).

EN 61000-6-4 Norma básica especializada para emisiones en la industria *(EN 50081-2)

Para la inmunidad frente a interferencias se aplica lo siguiente:

EN 61000-6-1 Norma básica especializada para la inmunidad frente a interferencias en áreas residenciales *(EN 50082-1)

EN 61000-6-2 Norma básica especializada para la inmunidad frente a interferencias en la industria. Si se cumple esta norma, también se cumple automáticamente la norma EN 61000-6-1 *(EN 50082-2).

* Las normas genéricas se muestran entre paréntesis

			Normas
Segundo entorno (industria) con categorías PDS C3, C4			EN 61800-3
No aplicable			EN 61000-6/3
conforme	a petición del cliente	conforme	EN 61000-6/3
conforme			EN 61000-6-2 EN 61000-6-1

Categoría PDS C3

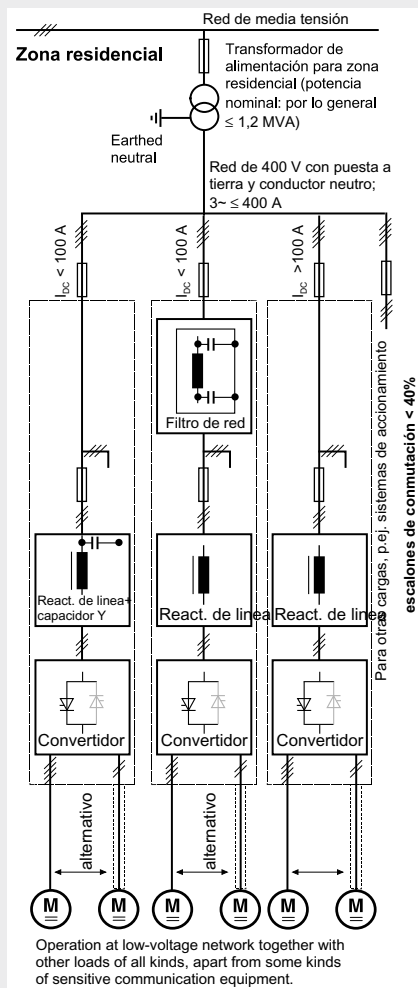

Categoría PDS C4

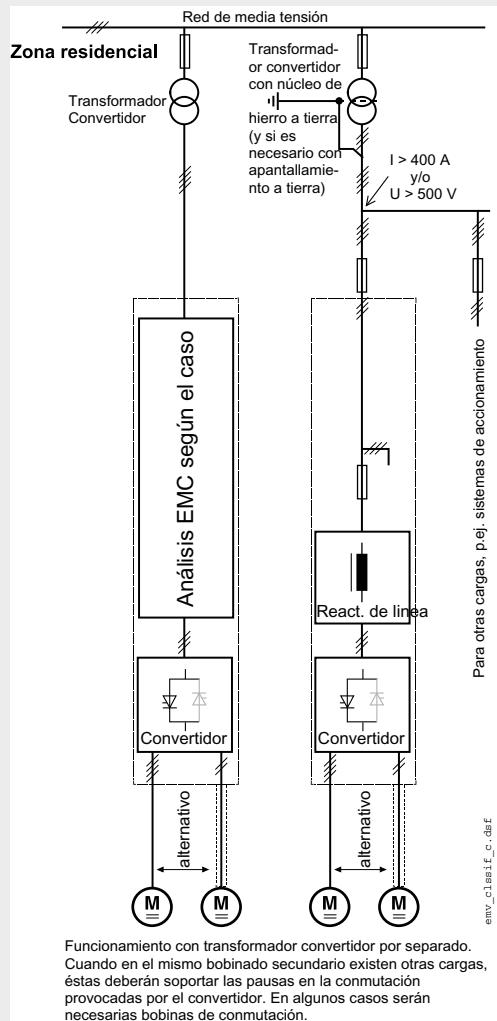

Clasificación

La siguiente descripción general utiliza la terminología e indica las acciones necesarias conforme a la norma de producto

EN 61800-3

Para la serie DCS800 se cumplen los valores límite de emisión de interferencias, a condición de que se realicen las medidas indicadas. Los PDS de categoría C2 (antes distribución restringida en primer entorno) están pensados para ser instalados y puestos en funcionamiento sólo por un profesional (persona u organización con los conocimientos necesarios sobre la instalación y/o puesta en funcionamiento de PDS, incluidos los aspectos relativos a la EMC).

La advertencia siguiente es aplicable para convertidores de potencia sin componentes adicionales:

Este producto es de categoría C2 conforme a la norma IEC 61800-3:2004. Este producto puede causar interferencias de radiofrecuencia en un entorno doméstico o residencial, en cuyo caso puede ser necesario tomar acciones correctoras suplementarias.

La advertencia siguiente es aplicable para convertidores de potencia sin componentes adicionales:

Este producto es de categoría C2 conforme a la norma IEC 61800-3:2004. Este producto puede causar interferencias de radiofrecuencia en un entorno doméstico o residencial, en cuyo caso puede ser necesario tomar acciones correctoras suplementarias.

Legend

	Screened cable
	Unshielded cable with restriction

español

Standard function assignments for the terminals

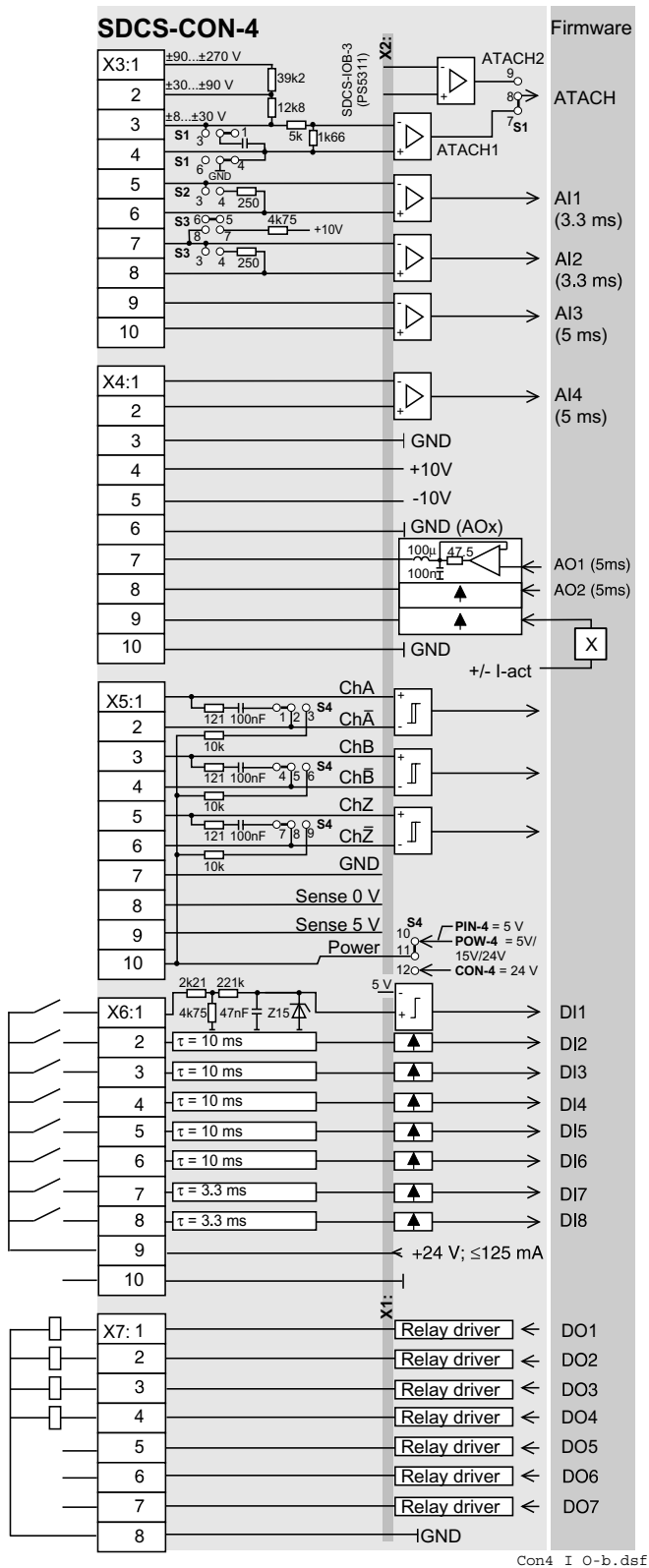

Resolución [bits]	Valores de entrada/salida Hardware	Escalado mediante	Rango de modo común	Comentarios
15 más signo	±90...±270 V ±30...±90 V ±8...±30 V	① Firmware	±15 V	
15 más signo	-10...0...+10 V	Firmware	±15 V	
15 más signo	-10...0...+10 V	Firmware	±15 V	
15 más signo	-10...0...+10 V	Firmware	±15 V	
15 más sig.	-10...0...+10 V	Firmware	±15V	

		Potencia		
	+10 V	≤ 5 mA	para uso ext. p. ej. pot. de ref..	
	-10 V	≤ 5 mA		
11 más sig.	-10...0...+10 V	Firmware	≤ 5 mA	
11 más sig.	-10...0...+10 V	Firmware	≤ 5 mA	
	-10...0...+10 V	Firmware+ Hardware	≤ 5 mA	8 V -> min. de 325% of [99.03] o 230% de [4.05]

Alimentac. del generador de pulsos	Comentarios	
	Entradas no aisladas Impedancia = 120 Ω, si se selecciona frecuencia máx. ≤ 300 kHz	
5 V 24 V	≤ 250 mA ≤ 250 mA	Líneas de detección de tierra y alimentación para corregir caídas de tensión en el cable (sólo si se emplea el generador de pulsos de 5 V)

Valor de entrada	Señal definida mediante	Comentarios
0...7.3 V 7.5...50 V	Firmware	-> "0" estado -> "1" estado

Valor de salida	Señal definida mediante	Remarks
50 * mA 22 V sin carga	Firmware	Límite de intensidad para las 7 salidas = 160 mA No aplique tensiones inversas!

* protección contra cortocircuitos
 ① la ganancia puede modificarse en 15 pasos entre 1 y 4 mediante parámetros de software

Ejemplo de conexión

Configuración de los convertidores D1...D4 utilizando un excitador de campo, incorporado' Selección del terminal según la macro de fábrica (FACTORY) (por defecto)

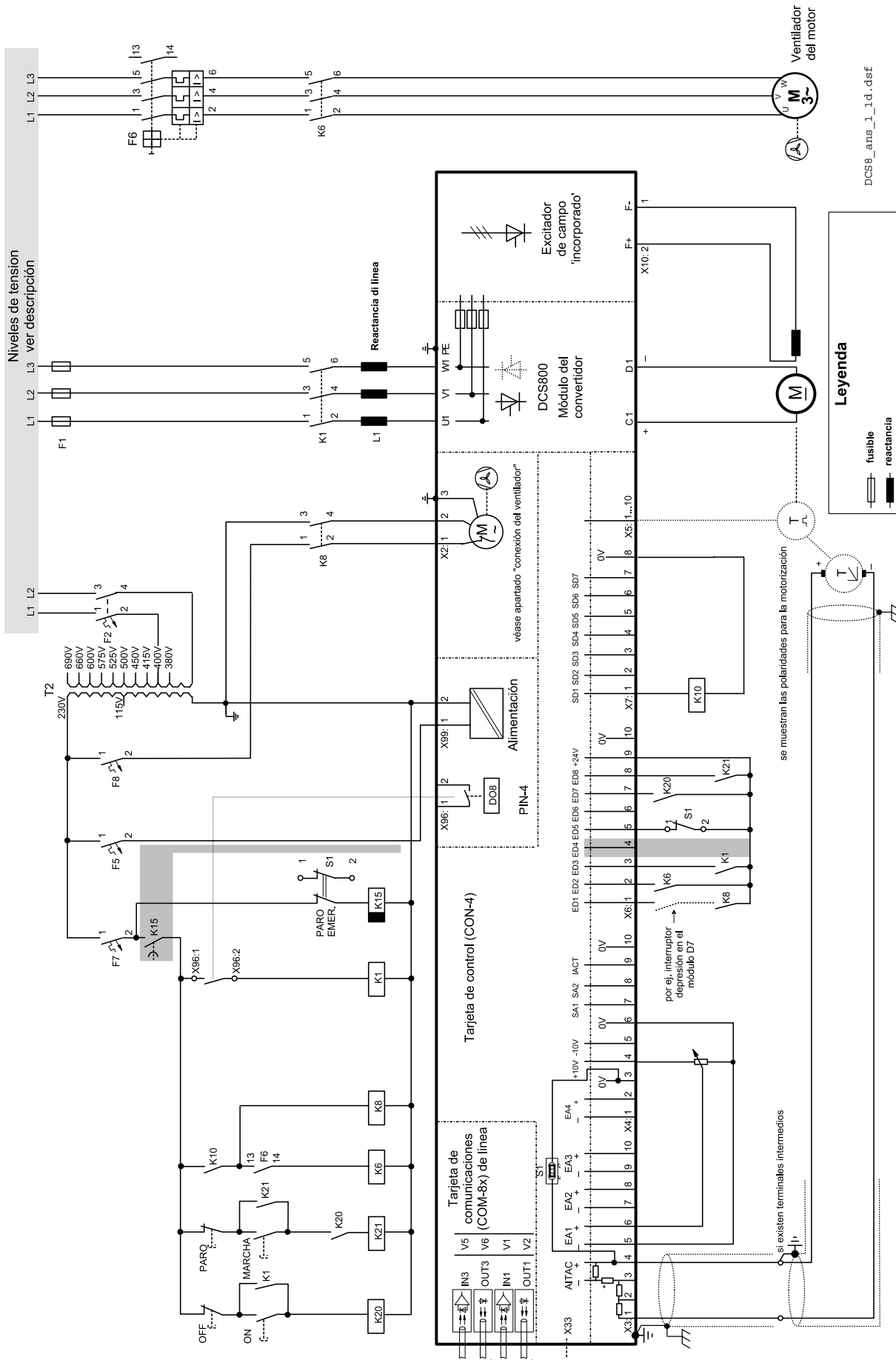

para más información véase la página siguiente

español

Control de marcha, paro y paro de emergencia

La lógica de relé puede dividirse en tres partes:

a: Generación de las órdenes ON/OFF (activado/desactivado) y START/STOP (marcha/paro):

Los comandos representados por K20 y K21 (relé de interfaz de bloqueo) pueden generarse, p. ej., mediante un PLC y transferirse a los terminales del convertidor ya sea a través de relés, utilizando aislamiento galvánico o directamente a través de señales de 24 V.

Estas órdenes también se pueden transferir mediante comunicación en serie. Incluso puede optarse por una solución mixta mediante la selección de posibilidades distintas para cada señal (véase el grupo de parámetros 11).

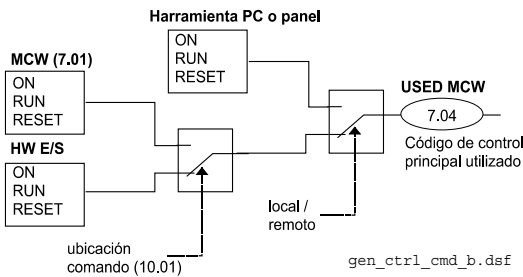

b: Generación de las señales de control y supervisión:

El contactor principal K1 para el circuito del inducido está controlado por un contacto seco (SD 8) situado en el SDCS-PIN-4. El estado de los ventiladores y el Klixon de los ventiladores se pueden supervisar mediante señales de confirmación del ventilador: MotFanAck (10.06) y ConvFanAck (10.20).

c: Función de paro OFF2, OFF3:

Además de las funciones ON/OFF y START/STOP el convertidor dispone de dos funciones de paro adicionales, OFF2 y OFF3, de acuerdo con la norma Profibus. OFF3 es una función de paro escalable (paro por rampa, paro por par máximo, freno dinámico, etc.) para la categoría de paro 1. Esta función debe conectarse al botón de paro de emergencia (E-STOP) sin ninguna demora. En caso de una selección de paro por rampa, el relé temporizador K15 debe ajustarse a un tiempo superior al del parámetro EStopRamp (22.04). Para la selección de paro libre (COAST), el convertidor abre el contactor inmediatamente.

OFF2 desconecta la intensidad de CC lo más rápidamente posible y prepara el convertidor para la apertura del contactor principal o para disminuir la alimentación de red. Para una carga normal del motor de CC el tiempo de desconexión de la intensidad de CC está por debajo de 20 ms. Esta función debe conectarse a todas las señales y funciones de seguridad que abran el contactor principal. Esta función es importante para convertidores de 4 cuadrantes. No abra el contactor principal durante la intensidad regenerativa.

La secuencia correcta es:

1. desconectar la intensidad regenerativa
2. abrir el contactor principal

En caso de que se pulse el botón de paro de emergencia, la información se transfiere al convertidor a través de la entrada digital 5. En caso de selección de paro por rampa o par máximo, el convertidor desacelera el motor y luego abre el contactor principal.

Si el convertidor no ha terminado la función dentro del ajuste de tiempo del temporizador K15, el convertidor debe recibir la orden de desconectar la intensidad a través del K16. Una vez transcurrido el tiempo ajustado en K16, el contactor principal se abre independientemente del estado del convertidor.

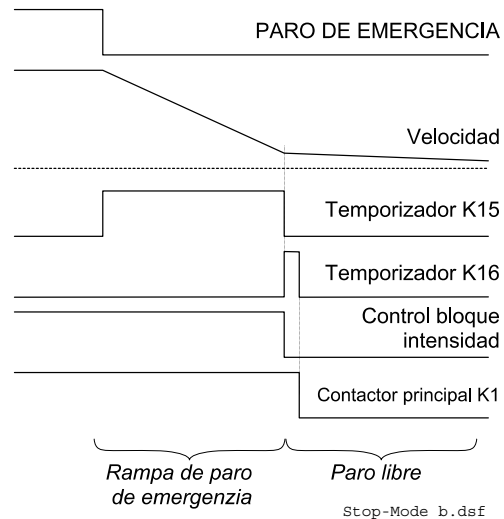
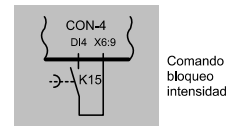
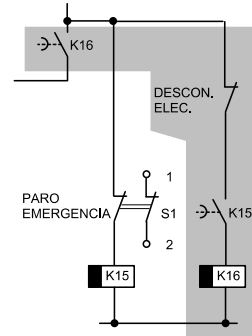

Reacción a una parada de emergencia

Conexión de alimentación del ventilador

Asignación de ventiladores para DCS800

Tipo de convertidor	Modelo	Configuración	Tensión del ventilador
DCS800-S01-0020-04/05 DCS800-S02-0025-04/05	D1	-	sin ventilador
DCS800-S0x-0045-04/05... DCS800-S0x-0140-04/05	D1	1	115 or 230 V CA
DCS800-S0x-0180-04/05... DCS800-S0x-0260-04/05	D2	1	115 or 230 V CA
DCS800-S0x-0315-04/05... DCS800-S0x-0350-04/05	D3	1	115 or 230 V CA
DCS800-S0x-0405-04/05... DCS800-S0x-0520-04/05	D3	2	115 or 230 V CA
DCS800-S0x-0610-04/05... DCS800-S0x-0820-04/05	D4	3	230 V CA
DCS800-S0x-0610-04/05... DCS800-S0x-0820-04/05	D4 Pluscode S171	3	115 V CA
DCS800-S0x-0900-04/05... DCS800-S0x-1000-04/05	D4	3	230 V CA
DCS800-S0x-0900-04/05... DCS800-S0x-1000-04/05	D4 Pluscode S171	3	115 V CA

Conexión del ventilador para DCS800

Terminales en la parte superior de la carcasa del convertidor

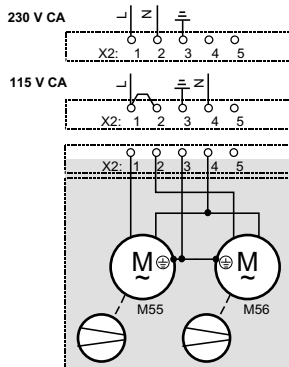

Configuración 1
D1-D3

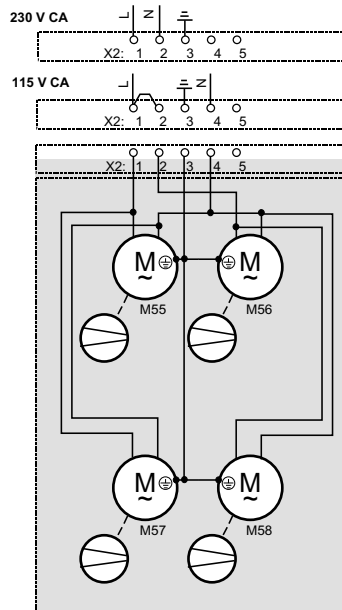

Configuración 2
D3

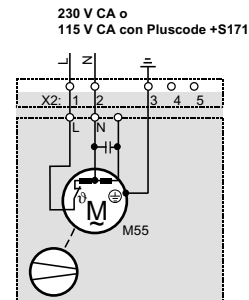

Configuración 3
D4

DCS8 fan conn D1-D4_a.dsrf

Ubicación de los terminales en el convertidor

SDCS-CON-4 ASIGNACIÓN DE TERMINALES

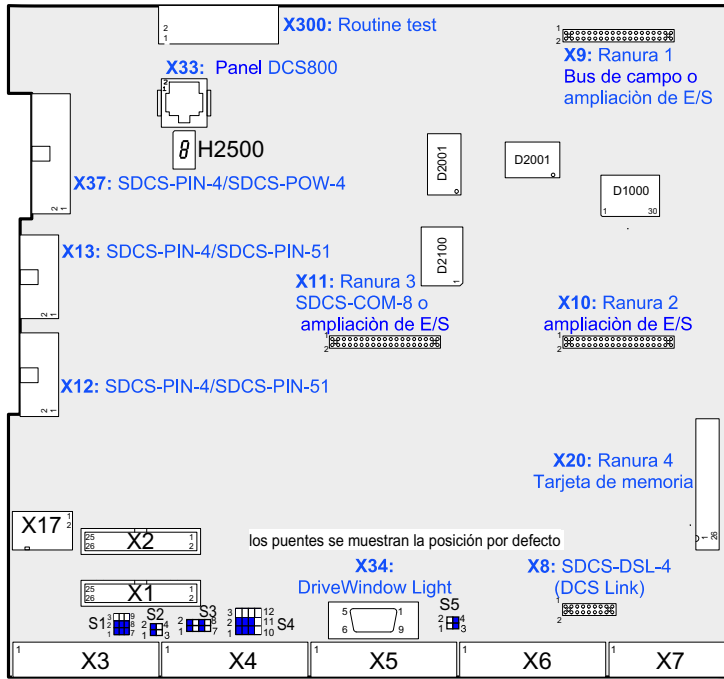

Módulo DCS800

ASIGNACIÓN DE TERMINALES

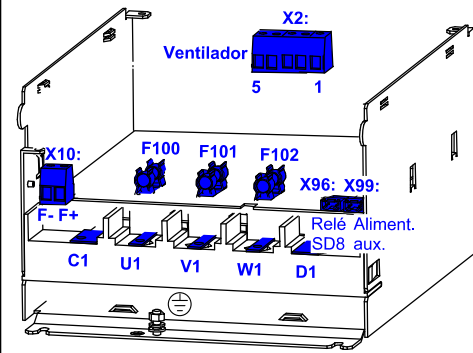

Accesorios DCS800

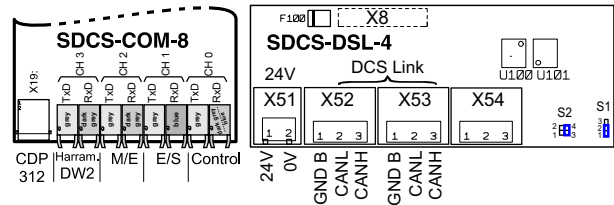

SDCS-CON-4: ASIGNACIÓN DE TERMINALES

X3 Tachómetro y EA										X4 EA y SA										X5 Generador de pulsos										X6 ED										X7 SD							
1	2	3	4	5	6	7	8	9	10	1	2	3	4	5	6	7	8	9	10	1	2	3	4	5	6	7	8	9	10	1	2	3	4	5	6	7	8	9	10	1	2	3	4	5	6	7	8
90...270V	30...90V	8...30V	0V	EA1-	EA1+	EA2-	EA2+	EA3-	EA3+	EA4-	EA4+	+10V	-10V	0V	SA1	SA2	SA3 (lact)	0V	+A	-A	+B	-B	+Z	-Z	GND	GND	Us	Detection	Us	ED1	ED2	ED3	ED4	ED5	ED6	ED7	ED8	+24	0V	SD1	SD2	SD3	SD4	SD5	SD6	SD7	SD8

DCS800 terminal alloc_a.dsf

Macro-Finder

Macro Name	Haupt-schütz	ON / OFF Start/Stop	DI Funktion	Kommentar	DI5 --> ESTOP DI6 --> Reset
Standard					
	AC	Static	Jog1 --> DI1 Jog2 --> DI2 Ext Fault --> DI 3 Ext Alarm --> DI4	Hardware I/O Steuerung	x
2-wire DC cont. US					
	DC	Static	Jog1 --> DI1 Jog2 --> DI2 Ext Fault --> DI 3 Main Cont Ack --> DI4	Hardware I/O Steuerung	x
3-wire DC cont. US					
	DC	Pulse	Fix speed1 --> DI1 Ext Fault --> DI 3 Main Cont Ack --> DI4	Hardware I/O Steuerung	x
3-wire Standard					
	AC	Pulse	Fix speed1 --> DI1 Ext Fault --> DI 3 Ext Alarm --> DI4	Hardware I/O Steuerung	x
Torque limit					
	AC	Static	Jog1 --> DI1 Jog2 --> DI2 Ext Fault --> DI 3 Ext Alarm --> DI4	Hardware I/O Steuerung + Torque limit	x
Manual / Const					
	AC	Pulse	Jog1 --> DI1 Jog2 --> DI2 Direction --> DI 3 SpC - KP, KI --> DI4	Hardware I/O Steuerung Verstärkung auswählen	x
Hand / Auto					
	AC	Static	Control select --> DI2 Reference select --> DI2 Direction select --> DI 3	Hardware I/O Steuerung oder Feldbussteuerung	x
Hand / Mot Pot					
	AC	Pulse	Motor pot up --> DI1 Motor pot down --> DI2 Direction select --> DI 3 Reference select --> DI4	Hardware I/O Steuerung Sollwert durch Hardware oder Motorpotentiometer	x
Motor Pot					
	AC	Static	Direction select --> DI 1 Motor pot up --> DI2 Motor pot down --> DI3 Motor pot minimum --> DI4	Hardware I/O Steuerung Sollwert durch Motor poten- tiometer	x
Torque Ctrl					
	AC	Static	OFF2 (coast stop) --> DI1 Torque select --> DI2 Ext Fault --> DI 3	Hardware I/O Steuerung Drehzahlregelungl oder Mo- mentensollwert	x

Habilitar un macro

Use el [DCS800Wizard] 2. Macro assistant of DriveWindow Light ò

Para utilizar el navegador de parámetros, ya sea a través del panel de control, DriveWindow, o DriveWindow Light.

Utilice los siguientes parámetros:

ApplMacro (99.08) = seleccionar
Apprestore (99.07) = YES = ejecutar el comando
MacroSel (8.10) = observando

NOTA

Las funciones y las entradas definidos por la macro se pueden cambiar más tarde sin restricciones

NOTA

Para el diagrama del macro consulte la página 93 ...

Instrucciones de seguridad



para convertidores de accionamiento DCS / DCF / DCR

(según: directriz de baja tensión 73/23/CEE)

1. General

Durante el servicio los convertidores de accionamiento pueden - según su tipo de protección - tener partes conduciendo corrientes, desnudos y dado el caso también partes móviles y rotantes, así como superficies calientes.

Al quitar inadmisiblemente el cubrimiento necesario, aplicación inadecuada, falso montaje o manejo hay el peligro de graves daños personales y materiales.

Otras informaciones son indicadas en la documentación.

Todos los trabajos para el transporte, la conexión, la puesta en funcionamiento y el mantenimiento deben ser ejecutados por el responsable personal cualificado (observar IEC 364 resp. CENELEC HD 384 o DIN VDE 0100 y IEC 664 o DIN VDE 0110 y las instrucciones nacionales para la prevención de accidentes).

Personal cualificado para los efectos de estas instrucciones de seguridad fundamentales son personas que son familiarizadas con la instalación, el montaje, la puesta en funcionamiento y el servicio del producto y que tienen las respectivas cualificaciones para su trabajo.

2. Aplicación de conformidad con las instrucciones

Convertidores de accionamiento son componentes destinados para el montaje en instalaciones eléctricas o máquinas.

Al instalarlos en máquinas la puesta en funcionamiento de los convertidores de accionamiento (es decir el arranque del servicio normal) es prohibida hasta que la conformidad de la máquina con la directriz de la CE 89/392/CEE (directriz de máquinas) hizo constado; observar EN 60204.

La puesta en funcionamiento (es decir el arranque del servicio normal) se permite solamente si la directriz de CEE (89/336/CEE) es observada.

Los convertidores de accionamiento responden a las especificaciones de la directriz de baja tensión 73/23/CEE. Las normas armonizadas de la serie prEN 50178/DIN VDE 0160 junto con la EN 60439-1/VDE 0660 Parte 500 y EN 60146/ VDE 0558 se aplican a los convertidores de accionamiento.

Los datos técnicos así como las instrucciones para la conexión se indican sobre la placa de características y en la documentación y deben ser observados estrictamente.

3. Transporte, almacenamiento

Las instrucciones para el transporte, el almacenamiento y el manejo adecuado deben ser observadas.

Las condiciones climáticas deben responder a la prEN 50178.

4. Instalación

La instalación y la refrigeración de los aparatos han de ser ejecutadas según las especificaciones de la documentación correspondiente.

Los convertidores de accionamiento deben ser protegidos contra cargas inadmisibles. En particular no se admiten componentes deformados y/o distancias de aislamiento modificadas resultando del transporte y del manejo. No tocar los componentes electrónicos y los contactos.

Los convertidores de accionamiento contienen componentes electrostáticamente sensitivos, que pueden ser dañados por un manejo inadecuado. Componentes eléctricos no deben ser dañados y deteriorados mecánicamente (posiblemente perjudicial a la salud!).

5. Conexión eléctrica

Para trabajos a los convertidores de accionamiento bajo tensión se deben observar las vigentes instrucciones nacionales para la prevención de accidentes (p.e. VBG 4).

La instalación eléctrica debe ser ejecutada según las instrucciones correspondientes (p.e. secciones transversales de las líneas, fusibles, conexión del conductor de protección). Otras informaciones son indicadas en la documentación.

Instrucciones para la instalación conforme a las especificaciones CEM - como pantalla, puesta a tierra, colocación de filtros y cableado - son indicadas en la documentación del convertidor de accionamiento. También para los convertidores de accionamiento con una identificación CE estas instrucciones siempre han de ser observadas. El fabricante de la instalación o máquina es responsable para la observación de los valores límites fijados por la ley de CEM.

6. Funcionamiento

En caso de necesidad las instalaciones que tienen convertidores de accionamiento han de ser provistas de dispositivos de vigilancia y de protección adicionales según las directrices en razón de la seguridad, por ejemplo la ley sobre equipos técnicos, instrucciones para la prevención de accidentes etc. No se permiten modificaciones de los convertidores de accionamiento mediante del software de control.

Después de haber desconectado los convertidores de accionamiento de la tensión de alimentación no tocar inmediatamente los partes de aparatos bajo tensión y los cables de potencia a causa de condensadores posiblemente cargados. Observar las respectivas placas indicadoras y identificaciones sobre el convertidor de accionamiento.

Durante el servicio todos los cubrimientos y las puertas han de quedarse cerrados.

7. Mantenimiento y conservación

Observar la documentación del fabricante.

Quédese Vd. estas instrucciones de seguridad!

Cómo instalar las herramientas para PC del DCS800

Una vez insertado el CD del DCS800, todos los programas y documentación necesarios para trabajar con el convertidor se instalan automáticamente. Esto incluye:

1. DriveWindow Light para la parametrización, puesta en funcionamiento y servicio
2. Hitachi FDT 2.2 para la descarga del firmware
3. CD de instalación del convertidor DCS800, p. ej. el asistente DWL y documentos de ABB
4. CoDeSys para la programación de aplicaciones 61131

Atención:

Si no desea instalar un programa en concreto, simplemente ignórela mediante la opción cancelar (Cancel) al inicio del asistente del programa.



Si la instalación rutinaria no se inicia automáticamente:

- Vaya a Start/Run y busque el archivo setup.exe en el CD. Ahora inicie la instalación tras confirmar con OK
- Se recomienda la instalación compacta para DriveWindow Light + Commissioning Wizard + DriveWindow Light AP

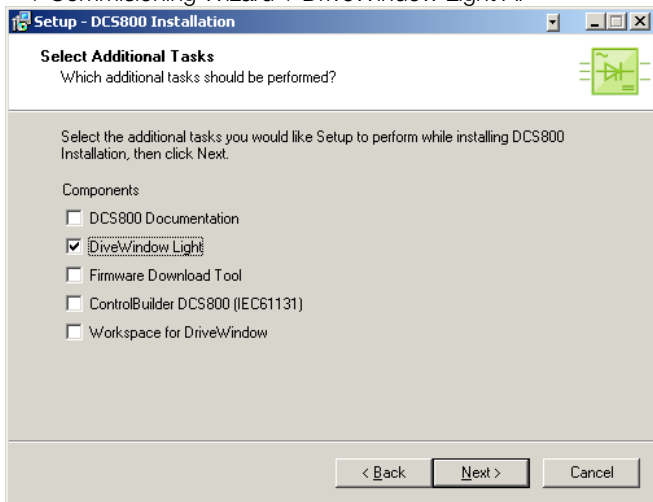

Pasos para la conexión del convertidor a un ordenador

- La documentación se encuentra en **C:\ABB\DCS800\Docu**
- Retire la cubierta de diseño del módulo del convertidor



Retire el panel de control del DCS800 si está colocado. Libere los bloqueos para retirar la cubierta



Conecte el convertidor (X34) al puerto COM de su PC

- Inicie la herramienta de PC DriveWindow Light
Compruebe los ajustes de comunicación para el puerto COM

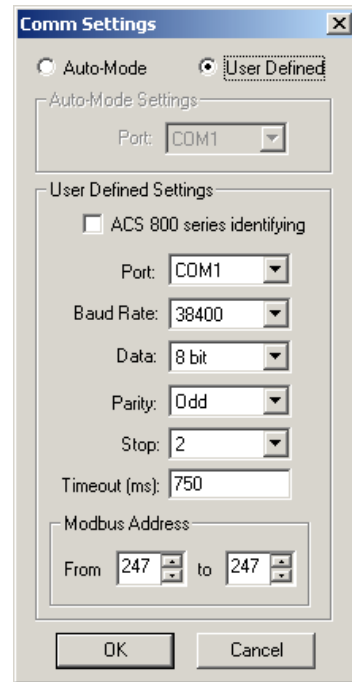

Si utiliza conexión USB para la interfaz del puerto COM o adaptadores PCMCIA / COM compruebe bien el COM activo habilitado

Start => Settings => Control Panel => System => Hardware => Device Manager

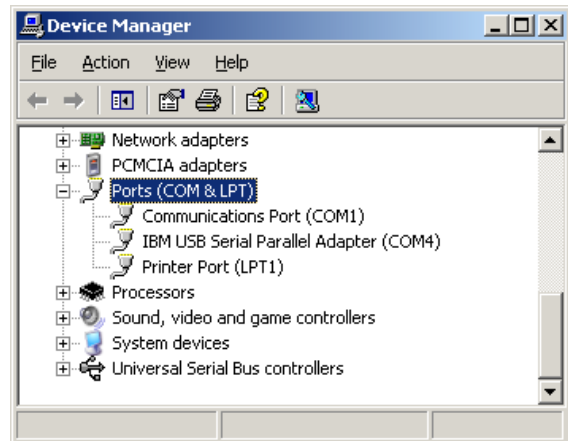

La dirección COM de la interfaz USB puede cambiar después del siguiente proceso de arranque o después de desconectar y volver a conectar la interfaz USB.

Nota:

El PCMCIA en el puerto COM proporciona una interfaz del convertidor más estable y rápida.

Utilice DriveWindow Light o el Panel Wizard del DCS800 y continúe con el capítulo Puesta en funcionamiento del manual.

Para la puesta en funcionamiento mediante DriveWindow puede encontrar una descripción del espacio de trabajo en el Manual de firmware del DCS800.

Puesta en funcionamiento



¡Peligro! Alta tensión: este símbolo previene de altas tensiones que pueden causar lesiones físicas y/o daños al equipo. Cuando procede, el texto impreso al lado de este símbolo describe cómo prevenir este tipo de riesgo.



Advertencia general: este símbolo previene de riesgos y peligros no relacionados con la electricidad que pueden causar lesiones físicas graves o incluso la muerte y/o daños al equipo. Cuando procede, el texto impreso al lado de este símbolo describe cómo prevenir este tipo de riesgo.



Advertencia sobre descargas electrostáticas: este símbolo previene de descargas electrostáticas que podrían dañar la unidad. Cuando procede, el texto impreso al lado de este símbolo describe cómo prevenir este tipo de riesgo.

Protección NEC contra sobrecarga del motor

El convertidor DCS800 proporciona una sólida protección contra sobrecarga del motor de conformidad con el Código Eléctrico Nacional de EE.UU (NEC). La protección contra sobrecarga (p. ej. nivel de protección en porcentaje de intensidad a plena carga del motor) puede ajustarse mediante los grupos de parámetros 31 y 99. Las instrucciones se encuentran en el capítulo Modelo térmico del motor del manual de firmware del DCS800.

Instrucciones generales

- Esta puesta en funcionamiento corta hace referencia al Capítulo 5 Ejemplos de conexión de esta publicación.
- *Instrucciones de seguridad y funcionamiento (véase el capítulo 6 de esta publicación).*
- Recomendación para tensiones del motor y de campo (véase Catálogo técnico).
- Conforme a la DIN 57 100 Parte 727 / VDE 0100 Parte 727, deben adoptarse precauciones que permitan apagar el convertidor, p. ej., en caso de peligro. Las entradas digitales de la unidad o el panel de control no son suficientes como única medida para dicho propósito.

Preparativos

- Compruebe si existen daños en la unidad
- Instale la unidad y efectúe las conexiones eléctricas
- Compruebe que el nivel de tensión de alimentación / el valor nominal son correctos para el equipo electrónico y el ventilador
- Compruebe que el valor nominal / nivel de tensión de alimentación son correctos para el convertidor de circuito del inducido
- Compruebe que el valor nominal / nivel de tensión de alimentación son correctos para la alimentación de campo
- Compruebe que las conexiones eléctricas / secciones transversales, etc. son correctas
- Compruebe que el PARO DE EMERGENCIA funciona correctamente
- Compruebe que el PARO LIBRE funciona correctamente

español

Puesta en funcionamiento de DriveWindow Light

inicie el asistente en DriveWindow

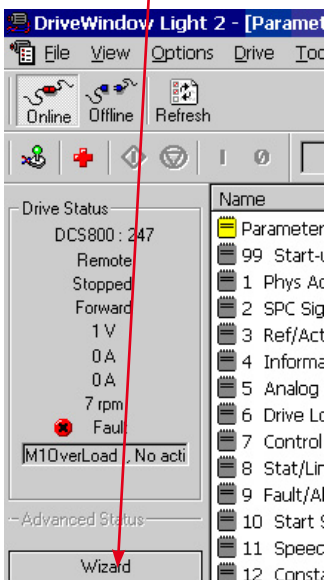

Para una puesta en funcionamiento básica pulse el botón de inicio (Start) o seleccione un asistente concreto:

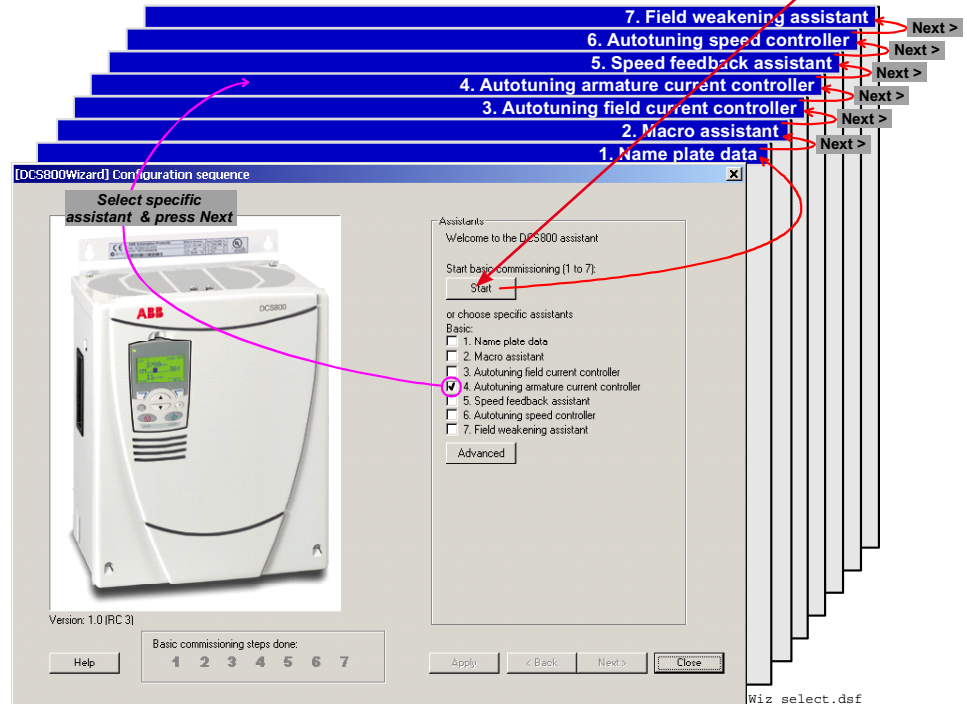

Para obtener más información acerca del asistente, parámetros y alarmas pulse el botón de ayuda (Help)

Panel de control del DCS800

The following table summarizes the button functions and displays of the DCS800 Control Panel (DCS CP).

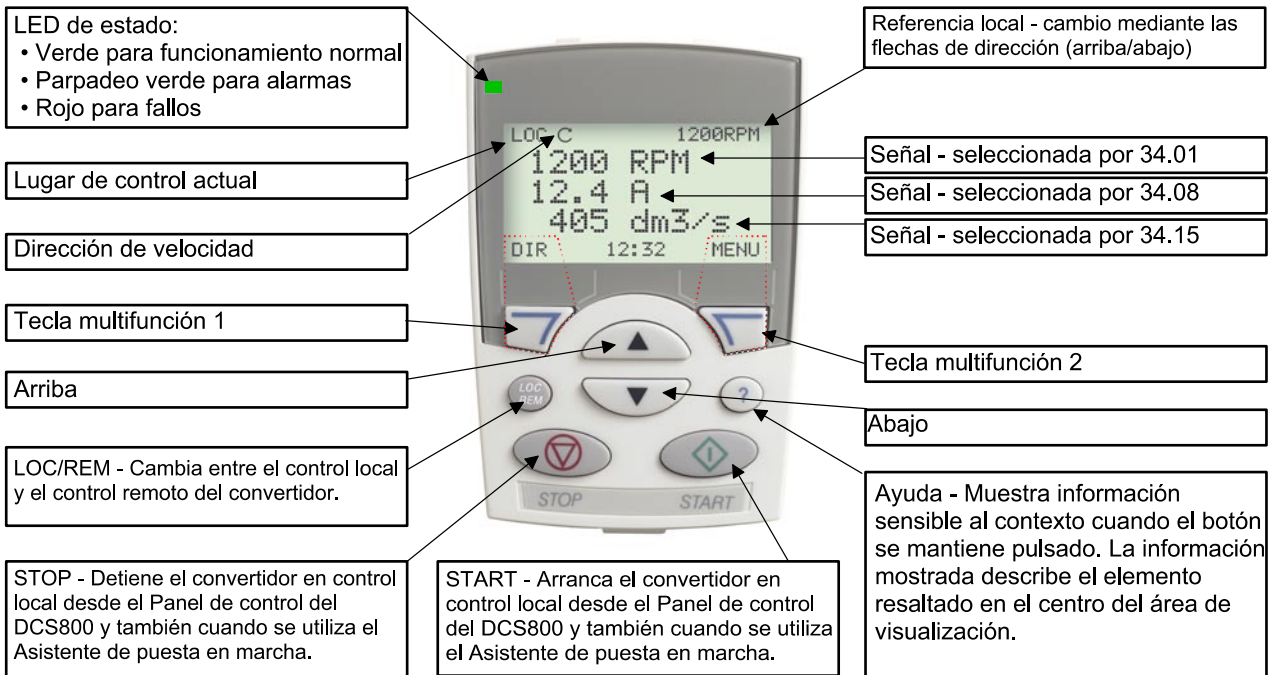

DCS800_QG_pan_ov_b.dsF

Con USISel (16.09) puede limitarse la cantidad de parámetros visualizados

Características generales de la pantalla

Los modos disponibles en el menú principal (MAIN MENU) son los siguientes:

1. Modo de parámetros
2. Modo de asistente de puesta en marcha
 - a. Datos de la placa de características
 - b. Asistente de macros
 - c. Autoajuste del regulador de intensidad de campo
 - d. Autoajuste del regulador de intensidad del inducido
 - e. Asistente de velocidad de realimentación (ajuste de precisión del tacómetro no disponible)
 - f. Autoajuste del regulador de velocidad
 - g. Asistente de debilitamiento de campo (sólo se utiliza cuando la velocidad máxima es superior a la básica)
3. Modo de macros (actualmente no se usa)
4. Modo de parámetros modificados (compara los valores por defecto y muestra los parámetros modificados)
5. Modo del registrador de fallos (muestra el historial de fallos)
6. Modo de ajuste del reloj
7. Modo de copia de seguridad de parámetros
 - copia el conjunto de parámetros activos del convertidor al panel de control del DCS800 (sólo en modo local)
 - copia el conjunto de parámetros del panel de control del DCS800 al convertidor (sólo en modo local)
8. Modo de ajustes de E/S (actualmente no se usa)

Parámetros introducidos por el asistente

99.02	Tensión nominal del motor 1
99.03	Intensidad nominal del motor 1
99.04	Velocidad básica del motor 1
20.01	Velocidad mínima del motor 1
20.02	Velocidad máxima del motor 1
99.11	Intensidad de campo nominal del motor 1
30.09	Nivel de sobreintensidad del inducido
30.16	Velocidad excesiva del motor 1
99.10	Tensión de red nominal
99.12	Excitación de campo utilizada en motor 1
20.05	Par máximo
20.06	Par mínimo
20.12	Puente 1 de límite de intensidad del motor 1
20.13	Puente 2 de límite de intensidad del motor 1
50.04	Número de pulsos del generador del motor 1, si se selecciona
50.02	Modo de generador de pulsos medido del motor 1, si se selecciona
50.13	Tensión del tacómetro del motor 1, sólo DWL
50.12	Adapt. del tacómetro del motor 1, sólo DWL
20.03	Límite de velocidad cero
22.01	Tiempo de aceleración 1
22.02	Tiempo de deceleración 1
30.12	Disparo mínimo de campo del motor 1
44.01	Modo de control de campo



La performance en standard

- Compacité
- Puissance
- Simplicité
- Convivialité (autocalibrage des régulateurs et assistants de mise en service)
- Adaptabilité
- Programmation CEI 61131

Variateurs à courant continu DCS800

Caractéristiques techniques

Tension réseau	230 à 1200 V, +/-10%, 3~
Fréquence	50 à 60 Hz, +/-5 Hz
Alimentation électronique	115 à 230 V, -15% / +10%, 1~
Courant sortie CC	20 à 5200 A
Capacité de surcharge	200 %
Contraintes d'environnement	
Tempér. ambiante	0 à +40 °C 40 à 55 °C avec déclassement
Tempér. stockage	-40 à +55 °C
Tempér. transport	-40 à +70 °C
Humidité relative	5 à 95 % sans condensation (50% maxi entre 0 et 5 °C)
Degré de pollution	Classe 2
Degré de protection	IP 00
Altitude	< 1000 m sans réduction du courant nominal > 1000 m avec réduction du courant

Entrées/sorties

Entrées logiques : 8 en standard, extensible jusqu'à 14 (bloc optionnel)
Sorties logiques : 8 en standard, extensible jusqu'à 12 (bloc optionnel)
Entrées analogiques : 4 en standard +/-10 V; 0/2...10 V, extensible jusqu'à 8 (bloc optionnel) +/- 20 mA; 0/4...20 mA
Sorties analogiques : 3 en standard (1x I_{ref}) +/-10 V; 0/2...10 V, extensible jusqu'à 7 (bloc optionnel) -20 mA; 0/4...20 mA

Outils logiciels PC

DriveWindow Light : fourni gratuitement avec chaque convertisseur, liaison RS232/PC standard
DriveWindow : liaison optique temps réel
ControlBuilder DCS800 : outil de programmation CEI 61131
DriveSize : dimensionnement du convertisseur et du moteur

Maintenance / Diagnostic

Télédiagnostic par PC/Internet partout dans le monde
 • avec navigateur internet / explorateur internet
 • ou avec DriveWindow, pilotage du variateur via OPC

Marquages   

Programmation adaptative

Blocs fonctions spécifiques variateur. Ex.,
 • Régulateur PI intégré (process)
 • Configuration personnalisée des E/S
 Avec micro-console ou outil logiciel PC, sans aucun équipement supplémentaire

Mesure vitesse

FEM
 Dynamo tachymétrique
 Codeur
 2ème codeur possible (RTAC)

Communication

Liaison série
 • Ethernet • Profibus
 • CANopen • DeviceNet
 • ControlNet • DDCS
 • Modbus
 • CS31 • AF100
 • Selma2
 Compatibilité Industrial IT®

DCSLink variateur-variateur

• jusqu'à 800 kBaod, < 2,5 ms
 • maître-esclave
 • convertisseur d'induit
 • convertisseur induit et excitation
 • données au choix

Solutions forte puissance

• 12 pulses jusqu'à 20000 A, série et parallèle
 • parallèle et séquentiel des modules entiers
 • jusqu'à 1500 V

Protections

Surveillance retour vitesse
 • Température • Surcharge • Survitesse • Moteur bloqué • Surintensité moteur • Surtension moteur • Surintensité excitation • Surtension excitation • Courant d'excitation mini • Vitesse nulle
 • Ondulation courant induit
 • Surtension et sous-tension réseau

Programmation CEI 61131

• Outil de programmation normalisé ouvert ControlBuilder DCS800
 • Multilingue (5 langages de programmation CEI)
 • Blocs fonctions spécifiques variateur
 • Sauvegarde du programme et de la source sur carte mémoire
 • Mise au point et forçage en ligne

Valeurs nominales, dimensions

Taille	2Q Courant nom. DCS800-01 I _{cc} [A]	4Q Courant nom. DCS800-02 I _{cc} [A]	Tension réseau [V _{ca}]							Courant maxi excit. interne [A _{cc}]	Dimensions	
			400	525	600	690	800	990	1200		h x l x p [mm]	h x l x p [pouce]
D1	20	25	●	●					6	370 x 270 x 200	14,56 x 10,65 x 7,90	
	45	50	●	●								
	65	75	●	●								
	90	100	●	●								
	125	140	●	●								
D2	180	200	●	●				15	370 x 270 x 270	14,56 x 10,65 x 10,65		
	230	260	●	●								
D3	315	350	●	●	● ³⁾			20	459 x 270 x 310	18,07 x 10,65 x 12,25		
	405	450	●	●								
	470	520	●	●								
D4	610	680	●	●	● ³⁾			25	644 x 270 x 345	25,35 x 10,65 x 13,60		
	740	820	●	●								
	900	1000	●	●								
D5	900	900	●	●	●	●		25	1050 x 510 x 410	41,35 x 20,10 x 16,15		
	1200	1200	●	●								
	1500	1500	●	●	●	●						
	2000	2000	●	●	● ¹⁾	● ¹⁾						
D6	1900	1900		●	●	●	●	Excitation externe 35A, 1~/3~ 50/60A, 1~ 520A, 3~	1750 x 460 x 410	68,90 x 18,15 x 16,15		
	2050	2050		●	●	●						
	2500	2500	●	●	●	●						
	3000	3000	●	●	●	●						
D7	2050	2050					●	Excitation externe 35A, 1~/3~ 50/60A, 1~ 520A, 3~	1750 x 760 x 570	68,90 x 29,95 x 22,45		
	2600	2600					● ²⁾					
	3300	3300	●	●	●	●	● ²⁾					
	4000	4000	●	●	●	●						
	4800	4800			●	●						
	5200	5200	●	●								

●¹⁾ uniquement disponible en variateur 2Q

●²⁾ sur demande

●³⁾ 600V

2Q -> 290 A / 590 A
 4Q -> 320 A / 650 A

Documentation technique

Vous avez acheté un variateur à courant continu ABB ; nous vous remercions de votre confiance et mettons tout en œuvre pour vous satisfaire.

Ce mémento a été rédigé pour vous aider à tirer le meilleur de notre produit. Il présente de manière succincte les caractéristiques clés du variateur, les règles de CEM, les applications types, la procédure de mise en route et de localisation des défauts.

Pour une information détaillée, un **CD-ROM** accompagne ce mémento. Il contient les documentations du variateur.

Documentation

La documentation technique du DCS800 comprend :

Catalogue technique (3ADW000192)

Contient toute l'information indispensable pour choisir vos systèmes d'entraînement à courant continu.

Manuel d'installation (3ADW000194)

Détaille toutes les spécifications du variateur et de ses composants (dimensions des modules, cartes électroniques, ventilateurs, auxiliaires).

Décrit les procédures de montage et de raccordement des appareils.

Manuel d'exploitation (3ADW000193)

Détaille toutes les fonctions et tous les paramètres des variateurs avec leurs réglages, ainsi que les procédures de mise en route et de maintenance.

Il décrit également la procédure de localisation des défauts avec les codes d'alarme et de défaut.

Manuel de maintenance (3ADW000195)

pour la maintenance et la réparation des convertisseurs.

Applications

Le variateur à courant continu DCS800 peut être livré avec un programme d'application (ex., levage, enroulage). Dans ce cas, certaines procédures ou des assistants peuvent être désactivés ou partiellement accessibles. Consultez la documentation et les manuels joints à la livraison (cf. paramètre 4.03, 83.01).

Vous trouverez des **informations complémentaires sur des applications** (ex., 12 pulses) et des **options** (ex., cartes d'extension ou interfaces bus de terrain) dans d'autres manuels. Cf. Liste des manuels de référence du *DCS800*.

Configuration requise pour lire le CD-ROM

- Système d'exploitation WINDOWS 2000, XP
- ACROBAT READER 4.0 au minimum (nous conseillons 8.0 qui se trouve sur le CD-ROM)



Si le CD-ROM ne démarre pas automatiquement, double cliquez sur **Setup.exe**.

Informations en ligne

Pour une satisfaction totale, vous trouverez des informations complémentaires sur nos domaines d'activités et nos produits en vous connectant sur notre site **Internet** à l'adresse suivante :

www.abb.com/dc

Vous y trouverez de nombreuses informations sur

- les produits courant continu
- les services
- les dernières mises à jour
- les outils logiciels
- les documents à télécharger, etc.

N'hésitez pas à vous connecter.

Contacts

Pour toute information complémentaire, contactez nos équipes **ABB Drives** ou envoyez un e-mail à :

DC-Drives@de.abb.com

en précisant votre nom, les coordonnées de votre entreprise et votre numéro de téléphone. Nous vous mettrons immédiatement en contact avec notre spécialiste.

Compatibilité électromagnétique (CEM)

Pour en savoir plus, cf. document :

Technical Guide, chapitre : EMC Compliant Installation and Configuration for a Power Drive System

Nous décrivons ci-après le mode de sélection des composants conformément aux normes de CEM.

L'objectif de la CEM est, comme son nom l'indique, d'assurer la compatibilité électromagnétique du variateur avec les autres produits et systèmes de son environnement. Elle vise à garantir un niveau d'émissions minimal de chaque produit pour éviter qu'il ne perturbe un autre produit de son environnement.

Pour la CEM d'un produit, deux aspects sont à prendre en compte :

- l'immunité aux perturbations du produit
- le niveau d'émissions effectif du produit

Les normes CEM supposent que le comportement CEM d'un produit est pris en compte au stade de son développement. Or la CEM n'étant pas une qualité intrinsèque, elle ne peut être mesurée que quantitativement.

Remarque sur la conformité CEM

La procédure de conformité relève de la double responsabilité du fournisseur du convertisseur de puissance et du constructeur de la machine ou du système dans lequel il s'intégrera, ce en fonction de la part des travaux qui leur incombe pour l'équipement électrique.

Premier environnement (zone résidentielle avec industrie légère) avec entraînement de puissance de catégorie C2	
Ne s'applique pas car la catégorie C1 en est exclue (distribution non restreinte)	
Non applicable	Conformité
Conformité	

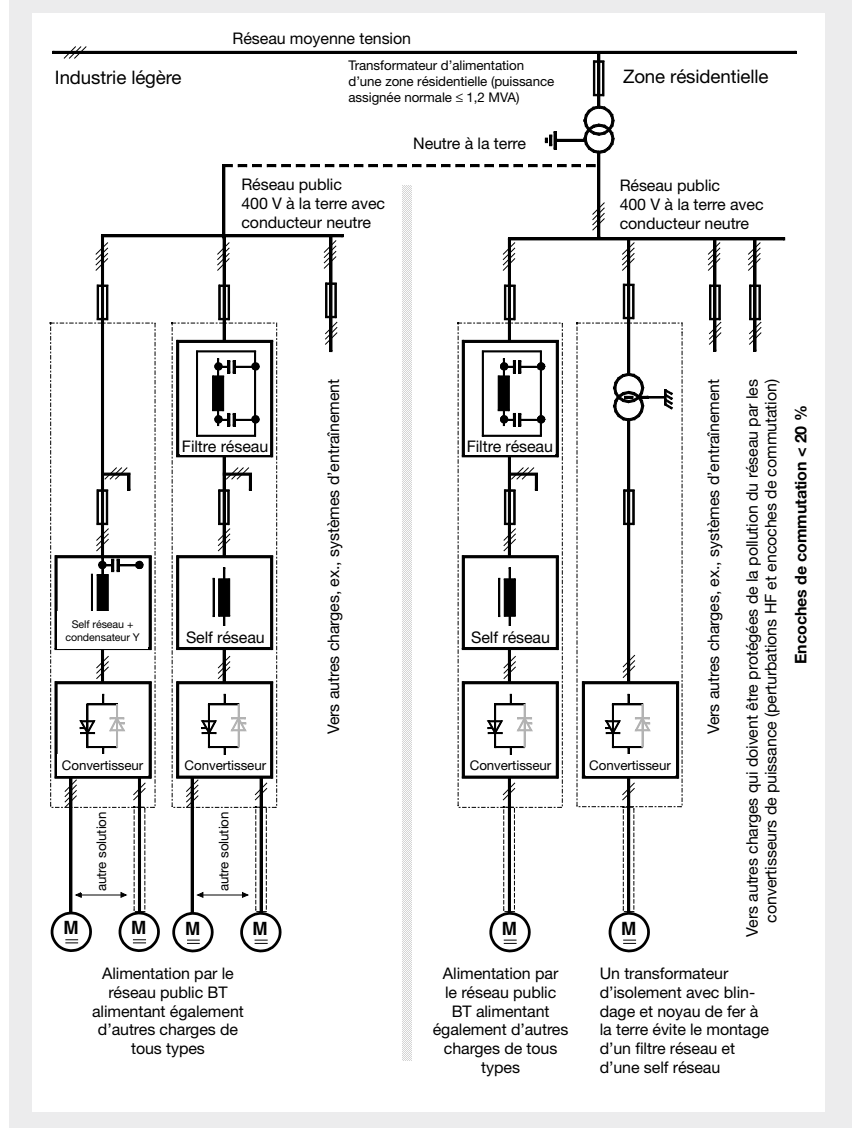
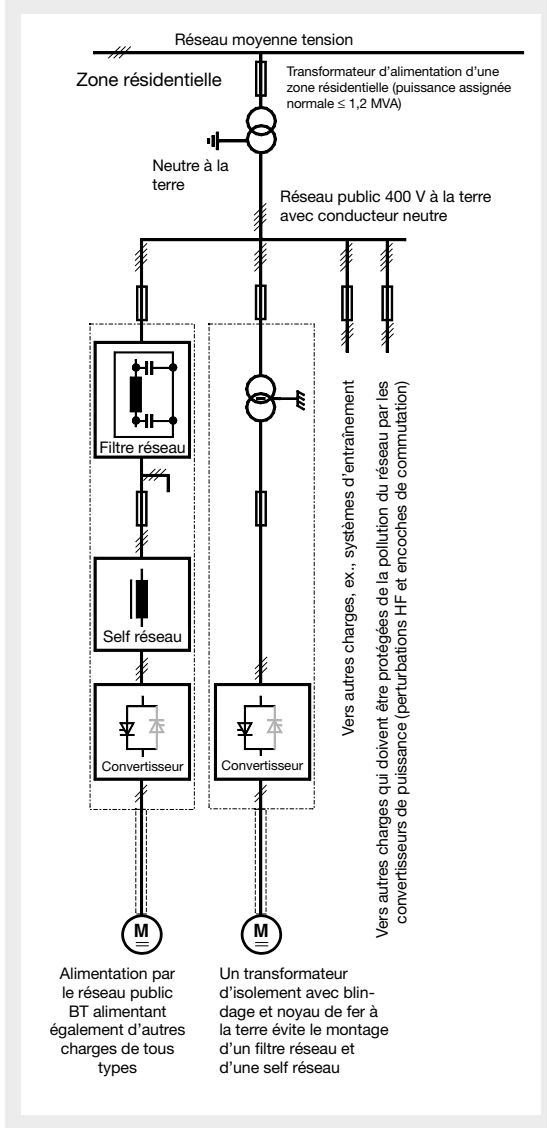

Pour obtenir la protection CEM des systèmes et machines, les exigences des normes CEM suivantes doivent être satisfaites :

Norme de produit EN 61800-3

Norme de **CEM** pour les entraînements de puissance PDS (**P**ower**D**rive**S**ystem), prescriptions d'immunité et d'émissions en environnements avec industrie légère et implantations industrielles.

Les exigences de cette norme doivent être respectées pour une installation conforme CEM des machines et sites industriels au sein de l'UE.

Pour les limites d'émissions, les normes suivantes s'appliquent :

EN 61000-6-3 Norme générique Emissions, **environnement d'industrie légère**, exigences respectées avec des dispositifs spéciaux (filtres réseau, câbles de puissance blindés) pour les faibles puissances.

EN 61000-6-4 Norme générique Emissions, **environnement industriel**

Pour les limites d'immunité, les normes suivantes s'appliquent :

EN 61000-6-1 Norme générique Immunité, **environnement résidentiel**

EN 61000-6-2 Norme générique Immunité, **environnement industriel**. Si les exigences de cette norme sont satisfaites, alors celles de la norme EN 61000-6-1 sont automatiquement satisfaites.

			Normes
Deuxième environnement (industriel) avec entraînement de puissance de catégories C3, C4			EN 61800-3
Non applicable			EN 61000-6/3
Conformité	Sur demande client	Conformité	EN 61000-6/3
Conformité			EN 61000-6-2 EN 61000-6-1

Entraînement de catégorie C3

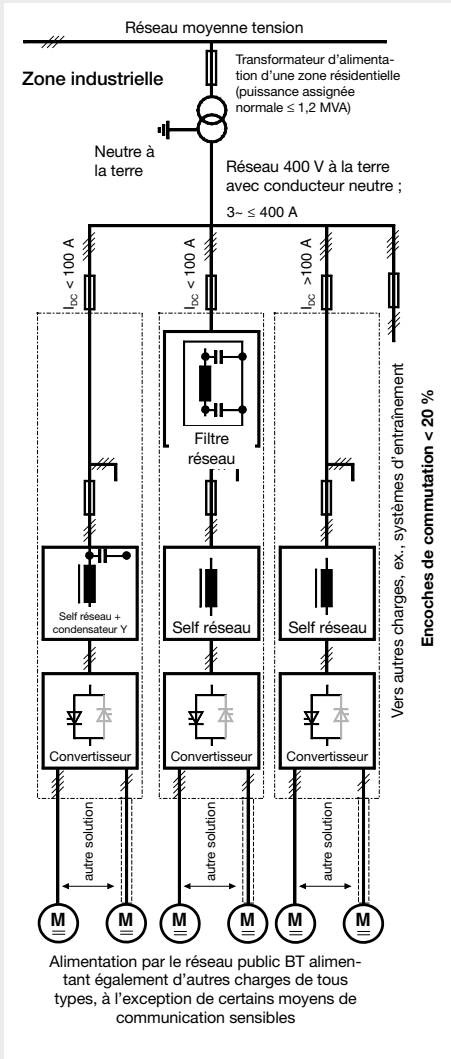

Entraînement de catégorie C4

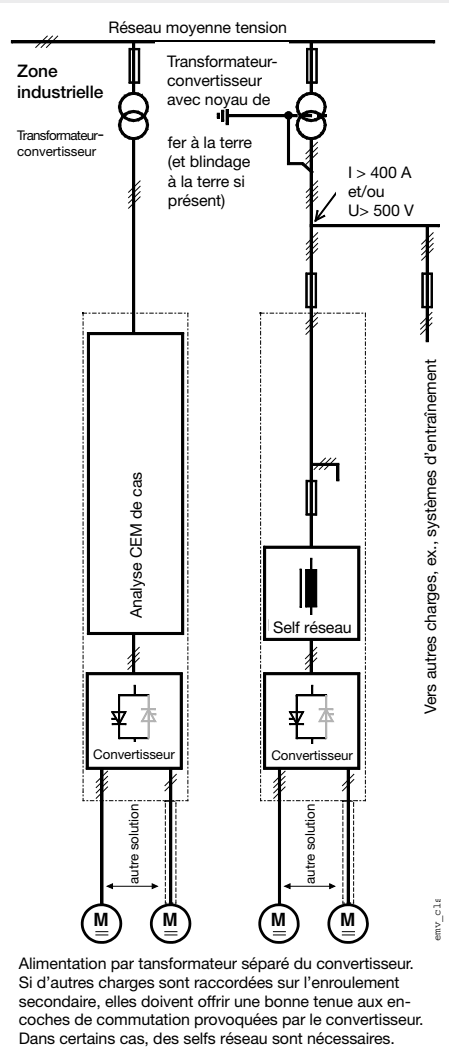

Classification

Nous définissons ci-après la terminologie et les mesures à mettre en œuvre pour la conformité à la norme de produit **EN 61800-3**. Pour la série DCS800, les limites d'émissions sont respectées pour autant que les mesures spécifiées sont mises en œuvre. Un entraînement de puissance de catégorie C2 (anciennement en distribution restreinte pour premier environnement) est destiné à être installé et mis en service uniquement par un professionnel (personne ou organisme qui dispose des compétences techniques requises pour l'installation et/ou la mise en service des entraînements de puissance, y compris les aspects CEM).

Convertisseur de puissance sans composants supplémentaires : Il s'agit d'un produit de catégorie C2 au titre de la norme CEI 61800-3:2004. En environnement domestique/résidentiel, il peut être à l'origine de perturbations HF, auquel cas des mesures appropriées d'atténuation doivent être prises.

L'excitation n'est pas illustrée dans les schémas. Les règles pour les câbles d'excitation sont les mêmes que celles pour les câbles d'induit.

Légende

- Câble blindé
- Câble non blindé avec restriction

français

Raccordement standard des signaux d'E/S

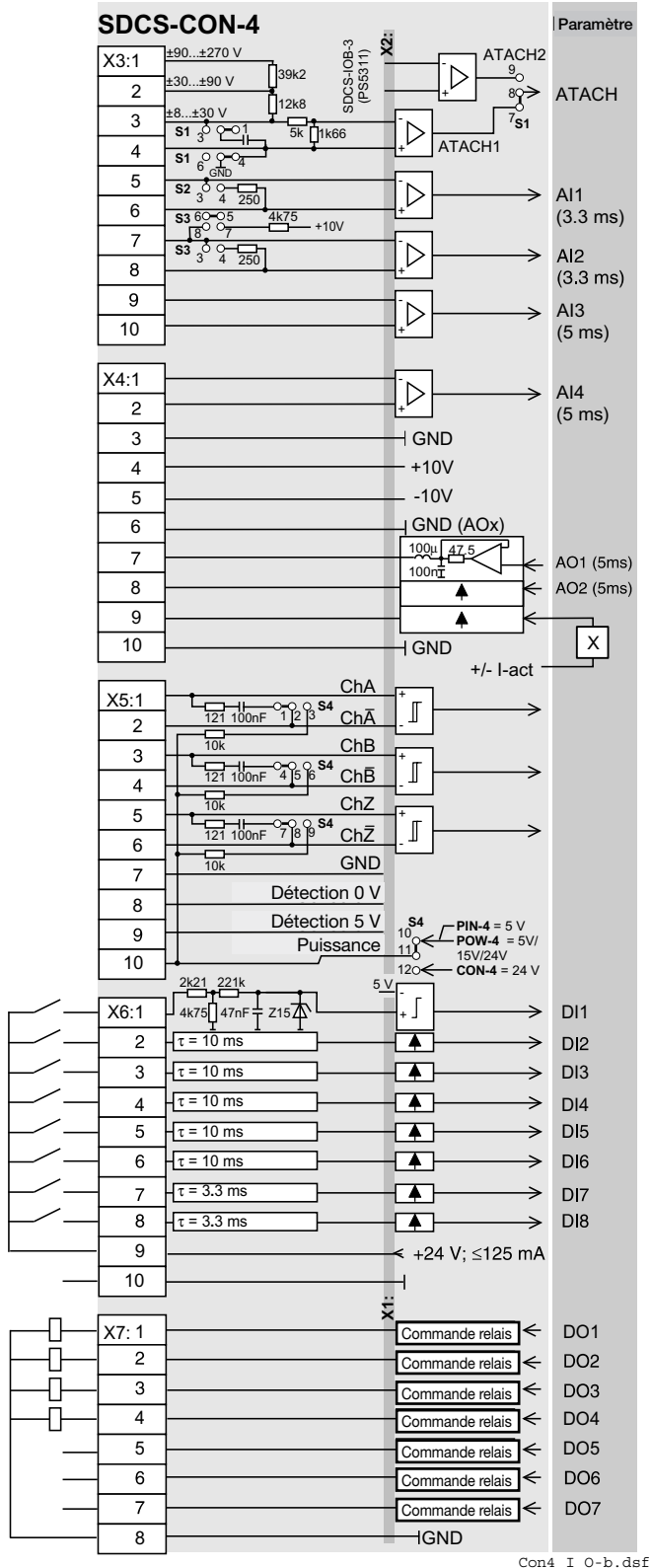

Résolution [bit]	Valeur des entrées/ sorties	Réglage par	Plage de mode commun	Remarques
15 + signe	±90...270 V ±30...90 V ±8...30 V	① Paramètre	±15 V	
15 + signe	-10...0...+10 V	Paramètre	±15 V	
15 + signe	-10...0...+10 V	Paramètre	±15 V	
15 + signe	-10...0...+10 V	Paramètre	±15 V	
15 + signe	-10...0...+10 V	Paramètre	±15 V	
			Puissance	
	+10 V		≤ 5 mA	Pour utilisation externe ; ex., potentiomètre de référence
	-10 V		≤ 5 mA	
11 + signe	-10...0...+10 V	Paramètre	≤ 5 mA	
11 + signe	-10...0...+10 V	Paramètre	≤ 5 mA	
	-10...0...+10 V	Paramètre + cavalier	≤ 5 mA	8 V -> min. de 325% of [99.03] ou 230% de [4.05]

Alimentation codeur	Remarques
	Entrées non isolées Impédance = 120 Ω, si sélectionnée Fréquence maxi ≤ 300 kHz
5 V 24 V	≤ 250 mA ≤ 250 mA
	Lignes de détection pour GND et alim. pour corriger les chutes de tension dans le câble (unq. si codeur 5 V utilisé)

Valeur d'entrée	Signal défini par	Remarques
0...7,3 V 7,5...50 V	Paramétrage	-> état «0» -> état «1»

Valeur de sortie	Signal défini par	Remarques
50 * mA 22 V à vide	Paramétrage	Limite de courant pour la totalité des 7 sorties = 160 mA Ne pas appliquer de tensions inverses !

* Protégée des courts-circuits
① Paramétrage du gain en 15 pas entre 1 et 4

Exemple de schéma de câblage

Configuration d'un variateur de taille D1 à D4 avec excitation intégrée Préréglage des paramètres du macroprogramme USINE

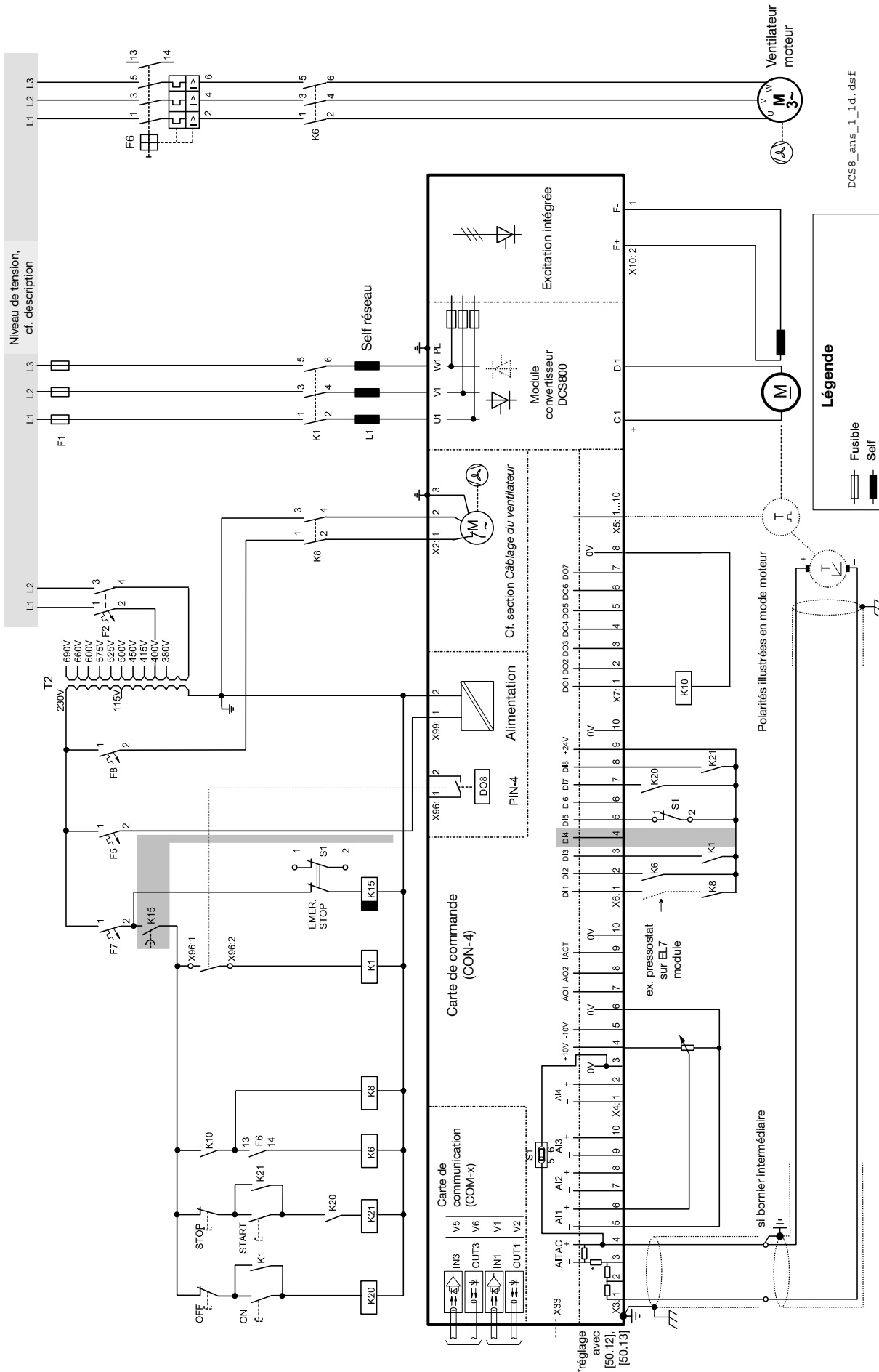

Pour des détails, cf. page suivante

Signaux de commande DEMARRAGE, ARRET et ARRET URGENCE

La logique de commande peut être divisée en trois parties :

a) Génération des signaux ENC/DECL et DEMAR/ARRET : ces signaux de commande représentés par les relais à verrouillage K20 et K21 peuvent, par exemple, provenir d'un automate (API) et être transmis sur les bornes du convertisseur soit par des relais à isolation galvanique soit directement en utilisant des signaux 24 V. Ces signaux peuvent également être transmis sur liaison série. Même une solution mixte peut être réalisée, en utilisant une option pour un signal et une autre pour un autre signal (cf. groupe de paramètres 11).

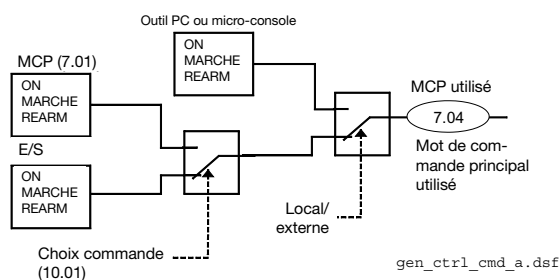

b) Génération des signaux de commande et de surveillance : Le contacteur principal K1 de l'alimentation (puissance du variateur) est commandé par un contact sec (DO 8) de la carte SDCS-PIN-4. L'état des ventilateurs et de leurs sondes klixon peut être surveillé avec les signaux d'acquit du ventilateur : AcqVentilMoteur (10.06) et AcqVentilConv (10.20).

c) Arrêts OFF2 (ArrUrg/RoueLibre), OFF3 (Arrêt Urgence) : Outre les types d'arrêt ENC/DECL et DEMAR/ARRET, le variateur offre deux types d'arrêt supplémentaires, OFF2 et OFF3, conformes Profibus. OFF3 est un type d'arrêt paramétrable (sur rampe, limite couple, freinage dynamique, ...) pour réaliser un arrêt de catégorie 1. Cette fonction doit être raccordée au bouton d'arrêt d'urgence (E-STOP) sans temporisation. Si un arrêt sur rampe est sélectionné, le relais temporisé K15 doit être réglé sur un délai plus long que RampArretUrgenc (22.04). Si un arrêt en roue libre est sélectionné, le variateur ouvre immédiatement le contacteur principal.

Le réglage OFF2 coupe le courant continu le plus vite possible et prépare le variateur à l'ouverture du contacteur principal ou à la coupure de la tension réseau. Pour une charge moteur CC normale, le temps de coupure du courant continu est inférieur à 20 ms. Ce type d'arrêt, important pour les variateurs 4Q, doit être raccordé à tous les signaux et fonctions de sécurité avec ouverture du contacteur principal. Ne pas ouvrir le contacteur principal pendant le fonctionnement en mode régénératif.

Séquence correcte :

1. coupure du courant régénératif, puis
2. ouverture du contacteur principal.

Si le bouton d'arrêt d'urgence (E-STOP) est activé, l'information est transmise au convertisseur via l'entrée logique DI5. Si un arrêt sur rampe ou par la limite de couple est sélectionné, le variateur décélérera le moteur et le contacteur principal s'ouvrira.

Si le variateur ne peut arrêter complètement le moteur au cours de la tempo spécifiée pour K15, il doit envoyer le signal de coupure du courant via K16. Après écoulement de la tempo de K16, le contacteur principal s'ouvre quel que soit l'état du variateur.

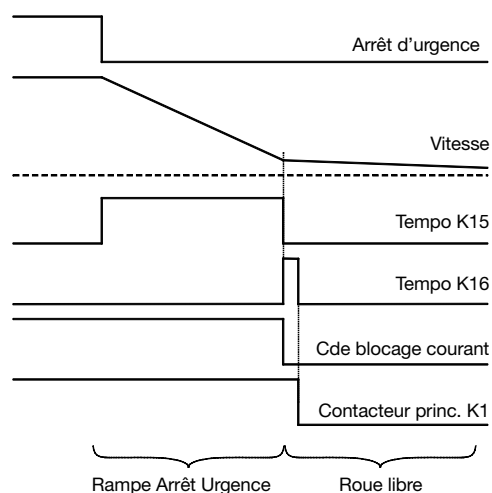
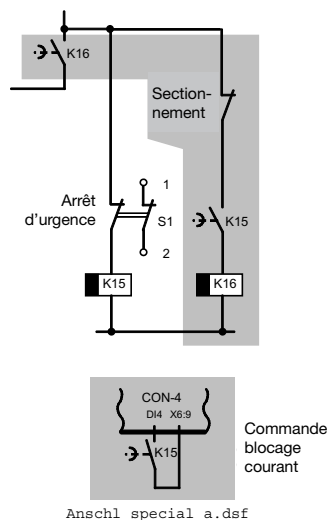

Séquence d'arrêt d'urgence (E-Stop)

Câblage du ventilateur

Type de ventilateur DCS800

Type de convertisseur	Taille	Configuration	Tension ventilateur
DCS800-S01-0020-04/05 DCS800-S02-0025-04/05	D1	-	sans ventilateur
DCS800-S0x-0045-04/05... DCS800-S0x-0140-04/05	D1	1	115 ou 230 VCA
DCS800-S0x-0180-04/05... DCS800-S0x-0260-04/05	D2	1	115 ou 230 VCA
DCS800-S0x-0315-04/05... DCS800-S0x-0350-04/05	D3	1	115 ou 230 VCA
DCS800-S0x-0405-04/05... DCS800-S0x-0520-04/05	D3	2	115 ou 230 VCA
DCS800-S0x-0610-04/05... DCS800-S0x-0820-04/05	D4	3	230 VCA
DCS800-S0x-0610-04/05... DCS800-S0x-0820-04/05	D4 code +S171	3	115 VCA
DCS800-S0x-0900-04/05... DCS800-S0x-1000-04/05	D4	3	230 VCA
DCS800-S0x-0900-04/05... DCS800-S0x-1000-04/05	D4 code +S171	3	115 VCA

Raccordement du ventilateur du DCS800

Bornier sur le dessus du convertisseur

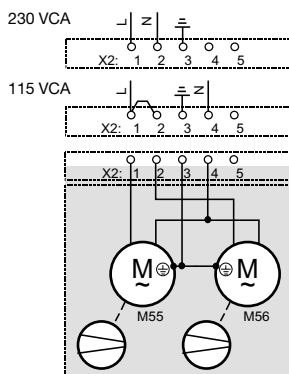

Configuration 1
D1-D3

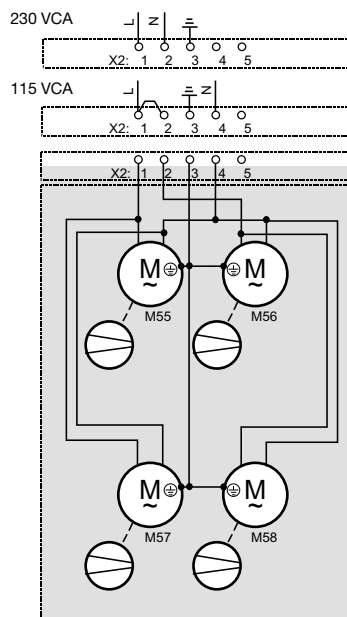

Configuration 2
D3

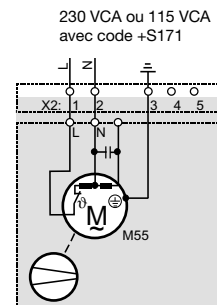

DCS8 fan conn D1-D4.dsf

Configuration 3
D4

Emplacement des bornes sur le convertisseur

Borniers de la carte SDCS-CON-4

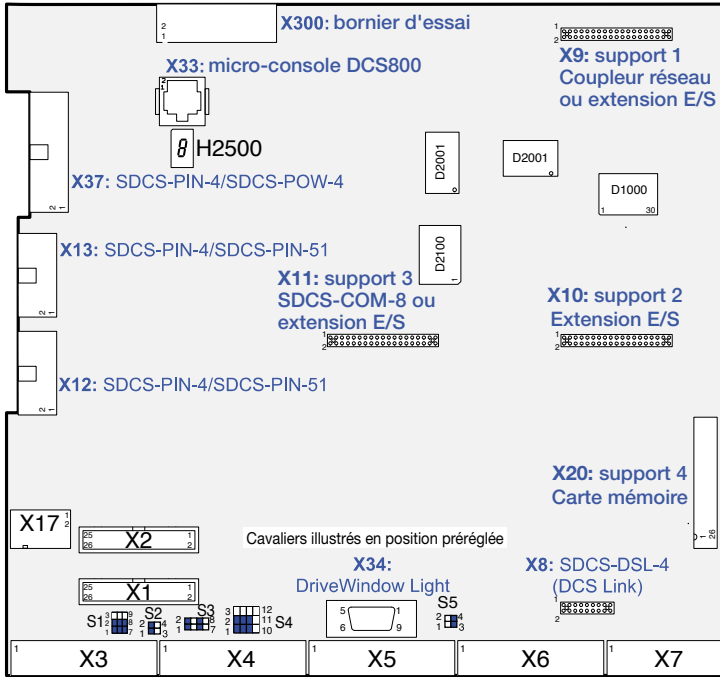

Bornes du module DCS800

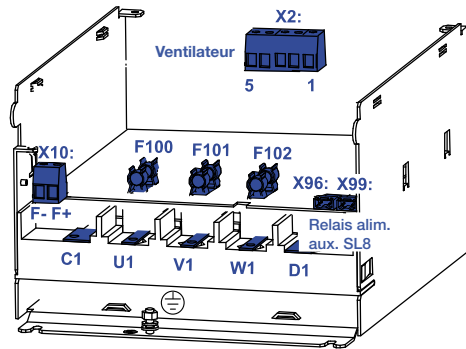

DCS800, accessoires

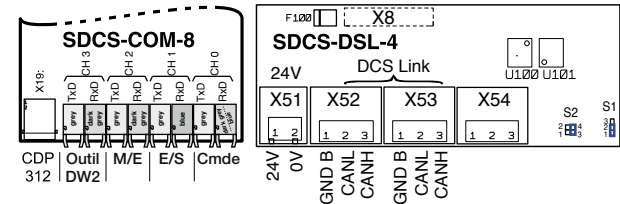

SDCS-CON-4: affectation des bornes

X3 Tachy et EA		X4 EA et SA		X5 Codeur		X6 EL		X7 SL	
1	2	1	2	1	2	1	2	1	2
90...270V	30...90V	0V	0V	+A	-A	D11	D12	DO1	DO2
8...30V	A11+	+10V	0V	+B	-B	D13	D14	DO3	DO4
	A11-	-10V	0V	+Z	-Z	D15	D16	DO5	DO6
	A12+	AO1	AO2	GND	Sense GND	D17	D18	DO7	DO8
	A12-	AO2 (fact)	0V	Sense Us	Sense Us	+24	0V		
	A13+								
	A13-								
	A14+								
	A14-								

DCS800 terminal alloc.dsdf

Macro-Finder

Macro Name	Haupt-schütz	ON / OFF Start/Stop	DI Funktion	Kommentar	DI5 --> ESTOP DI6 --> Reset
Standard					
	AC	Static	Jog1 --> DI1 Jog2 --> DI2 Ext Fault --> DI 3 Ext Alarm --> DI4	Hardware I/O Steuerung	x
2-wire DC cont. US					
	DC	Static	Jog1 --> DI1 Jog2 --> DI2 Ext Fault --> DI 3 Main Cont Ack --> DI4	Hardware I/O Steuerung	x
3-wire DC cont. US					
	DC	Pulse	Fix speed1 --> DI1 Ext Fault --> DI 3 Main Cont Ack --> DI4	Hardware I/O Steuerung	x
3-wire Standard					
	AC	Pulse	Fix speed1 --> DI1 Ext Fault --> DI 3 Ext Alarm --> DI4	Hardware I/O Steuerung	x
Torque limit					
	AC	Static	Jog1 --> DI1 Jog2 --> DI2 Ext Fault --> DI 3 Ext Alarm --> DI4	Hardware I/O Steuerung + Torque limit	x
Manual / Const					
	AC	Pulse	Jog1 --> DI1 Jog2 --> DI2 Direction select --> DI 3 SpC - KP, KI --> DI4	Hardware I/O Steuerung Verstärkung auswählen	x
Hand / Auto					
	AC	Static	Control select --> DI2 Reference select --> DI2 Direction select --> DI 3	Hardware I/O Steuerung oder Feldbussteuerung	x
Hand / Mot Pot					
	AC	Pulse	Motor pot up --> DI1 Motor pot down --> DI2 Direction select --> DI 3 Reference select --> DI4	Hardware I/O Steuerung Sollwert durch Hardware oder Motorpotentiometer	x
Motor Pot					
	AC	Static	Direction select --> DI 1 Motor pot up --> DI2 Motor pot down --> DI3 Motor pot minimum --> DI4	Hardware I/O Steuerung Sollwert durch Motor poten- tiometer	x
Torque Ctrl					
	AC	Static	OFF2 (coast stop) --> DI1 Torque select --> DI2 Ext Fault --> DI 3	Hardware I/O Steuerung Drehzahlregelung oder Mo- mentensollwert	x

Faire une macro

Utiliser [DCS800Wizard] 2. Macro assistant des DriveWindow Light ou

Utiliser le lecteur des paramètres, Utiliser le lecteur des paramètres.

utiliser les paramètres suivants:

AppMacro (99.08) = sélectionner la macro
Apprestore (99.07) = YES = exécuter la commande
MacroSel (8.10) = observant macro

NOTE
 Fonctions et entrées définies par une macro peuvent être changées plus tard sans restrictions.

NOTE
 Macro diagramme voir page 93 ...

Consignes de sécurité et d'exploitation



pour les convertisseurs DCS / DCF / DCR

(conformes à la directive Basse Tension 73/23/CEE)

1. Généralités

Selon leur degré de protection, les convertisseurs en fonctionnement peuvent comporter des parties nues sous tension ainsi que des pièces en mouvement ou en rotation, et des surfaces chaudes.

L'ouverture interdite des protections, son utilisation contraire à la destination finale, son installation incorrecte ou bien un dysfonctionnement sont susceptibles d'entraîner des blessures graves et des dégâts matériels.

Pour en savoir plus, consultez la documentation.

Le transport, l'installation, la mise en service et la maintenance doivent être réalisés par un personnel qualifié (respect des normes CEI 364 ou CENELEC HD 384, ou DIN VDE 100 et CEI 664 ou DIN/VDE 0110, et des règles nationales de prévention des accidents).

«Personnel qualifié» désigne les personnes au fait des procédures d'installation, de montage, de mise en service et d'exploitation du produit, et possédant les qualifications requises pour remplir leur mission.

2. Utilisation conforme à la destination

Les convertisseurs sont des composants destinés à être intégrés dans des installations ou machines électriques.

En cas d'incorporation à une machine, leur mise en service (mise en exploitation normale) est interdite tant que la conformité de la machine aux exigences de la Directive Machines 89/392/CEE n'est vérifiée ; la norme EN 60024 doit être respectée.

De même, la mise en service ne peut être réalisée que si les exigences de la Directive CEM (89/336/CEE) sont respectées.

Les convertisseurs satisfont les exigences de la Directive Basse Tension 73/23/CEE. Ils sont soumis aux exigences des normes harmonisées de la série prEN 50178/DIN VDE 0160 de même qu'à celles des normes EN 60439-1/ VDE 0660, partie 500 et EN 0146/ VDE 0558.

Les caractéristiques techniques et valeurs portées sur la plaque signalétique et celles figurant dans la documentation doivent rigoureusement être respectées.

3. Transport, stockage

Les consignes de transport, de stockage et d'utilisation doivent être respectées.

Les contraintes d'environnement au titre de la norme prEN 50178 doivent être respectées.

4. Installation

L'installation et le refroidissement des appareils doivent respecter les consignes de la documentation fournie avec le produit.

Les convertisseurs ne doivent être soumis à aucune contrainte excessive. En particulier, pendant le transport et la manutention, aucune pièce ne doit être déformée et les distances d'isolement doivent être respectées. Ne pas toucher les composants électroniques et les pièces nues.

Les convertisseurs contiennent des composants sensibles aux décharges électrostatiques susceptibles d'être endommagées en cas de manipulation incorrecte. Le matériel électrique ne doit pas être endommagé ni détruit (danger pour la santé !)

5. Raccordements électriques

En cas d'intervention sur des convertisseurs sous tension, la réglementation en vigueur doit être respectée (ex., VBG 4). L'installation électrique doit être conforme aux règles (ex., section des conducteurs, protection par fusibles, mise à la terre). Pour en savoir plus, cf. documentation.

Les consignes d'installation pour une conformité CEM (blindage, mise à la terre, emplacement des filtres et câblage) figurent dans la documentation qui accompagne les convertisseurs. Elles doivent être respectées dans tous les cas, même lorsque le convertisseur porte le marquage CE. Le respect des valeurs limites imposées par la réglementation CEM relève de la responsabilité de l'installateur ou du constructeur de la machine.

6. Exploitation

Les installations avec convertisseurs doivent comporter des dispositifs supplémentaires de protection et de surveillance prévus par la réglementation en vigueur sur la sécurité (équipements de protection, prévention des accidents, etc). La configuration et les fonctionnalités des convertisseurs peuvent être modifiées par logiciel.

Après sectionnement de la tension réseau, ne pas toucher immédiatement les parties actives et les bornes de puissance du variateur car des condensateurs peuvent encore être chargés. Respectez les consignes et mises en garde figurant sur les convertisseurs.

En cours d'exploitation, les portes, capots et autres protections doivent être fermés.

7. Entretien et maintenance

Consultez et respectez la documentation du constructeur.

CONSERVER CES CONSIGNES DE SECURITE EN LIEU SUR !

Installation des outils logiciels du DCS800 sur votre PC

Après insertion du CD-ROM du DCS800, tous les programmes et documents requis pour travailler sur le DCS800 sont automatiquement installés :

1. DriveWindow Light pour le paramétrage, la mise en service et la maintenance
2. Hitachi FDT 2.2 pour le chargement du logiciel (firmware)
3. CD d'installation du variateur DCS800 (ex., assistant DWL, documents ABB)
4. CoDeSys pour la programmation CEI 61131

Attention :

Si vous ne désirez pas installer un programme donné, cliquez sur Annuler (Cancel) au début de l'assistant du programme concerné.



Si l'installation n'est pas lancée automatiquement :

- Sélectionnez Démarrer/Exécuter et recherchez setup.exe sur le CD. Lancez l'installation en cliquant sur OK
- Nous conseillons l'installation compacte de DriveWindow Light + Commissioning Wizard + DriveWindow Light AP

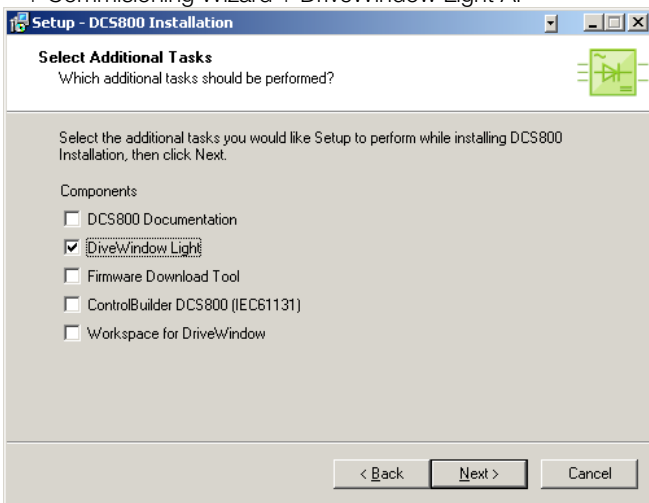

Raccordement du variateur au PC

- La documentation se trouve sous **C:\ABB\DCS800\Docu**
- Retirez le capot avant du module convertisseur



Retirez la micro-console du DCS800 si elle est insérée. Libérez les clips pour retirer le capot



Raccordez le variateur via le connecteur (X34) au port COM du PC

- Démarrez le programme DriveWindow Light
- Vérifiez les réglages de communication du port COM du PC

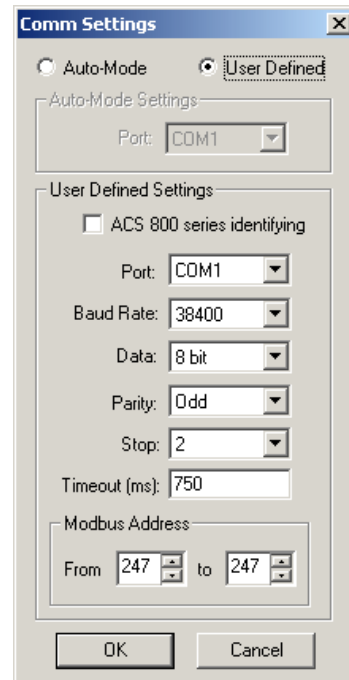

Si vous utilisez une interface USB-port COM ou des adaptateurs PCMCIA / COM, revérifiez les réglages du port COM : Démarrer => Paramètres => Panneau de configuration => Système => Matériel => Gestionnaire de périphériques

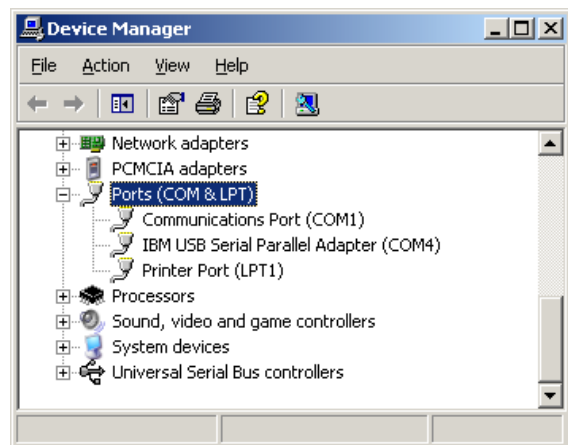

L'adresse du port COM attribuée pour l'interface USB **peut** changer après l'initialisation du PC ou après déconnexion/connexion de l'interface USB.

N.B. :

Le port PCMCIA - COM constitue une interface stable et à haut débit avec le variateur.

Si vous utilisez DriveWindow Light ou l'assistant de la micro-console du DCS800, continuez au chapitre *Mise en service* de ce document.

Pour la mise en service avec DriveWindow, cf. Manuel d'exploitation du DCS800.

Mise en service



Danger ! Haute tension : des tensions élevées peuvent provoquer des blessures graves et/ou endommager le matériel. Le texte qui se rapporte à ce symbole décrit la manière de se prémunir de ce danger.



Mise en garde générale : ce symbole met en garde contre des risques ou un danger d'origine non électrique susceptible d'entraîner des blessures graves, voire mortelles, et/ou des dégâts matériels. Le texte qui se rapporte à ce symbole décrit la manière de se prémunir de ce danger.



Risque de décharges électrostatiques : ce symbole attire votre attention sur les risques de décharges électrostatiques pouvant endommager l'appareil. Le texte qui se rapporte à ce symbole décrit la manière de se prémunir de ce danger.

Protection contre les surcharges moteur selon NEC

Le DCS800 intègre une protection électronique contre les surcharges moteur conforme NEC. Cette protection (ex., niveau de protection en % du courant moteur à pleine charge) peut être réglée avec les paramètres des groupes 31 et 99.

La procédure est décrite au paragraphe *Modèle thermique du moteur* du *Manuel d'exploitation du DCS800*.

Généralités

- Cette procédure résumée renvoie au *Chapitre 5* du Manuel d'installation. Exemple de raccordement dans ce mémento, p 68.
- *Consignes de sécurité et d'exploitation* - cf. *Chapitre 6* de ce mémento.
- Conseils pour les tensions moteur et d'excitation, cf. *Catalogue technique*.
- Conformément à DIN 57 100 Partie 727 / VDE 0100 Partie 727, des mesures doivent être prises pour arrêter le variateur en cas de danger, par exemple. En effet, les entrées logiques ou la micro-console du variateur ne suffisent pas à cette fin !

Étapes préalables

- Vérifiez l'état du variateur (aucun dommage !)
- Installez et câblez le variateur
- Alimentation de l'électronique et du ventilateur : vérifiez les niveaux de tension et les valeurs nominales
- Convertisseur d'induit : vérifiez les niveaux de tension et les valeurs nominales
- Excitation : vérifiez les niveaux de tension et les valeurs nominales
- Vérifiez, le câblage, la section des câbles, etc.
- Vérifiez le fonctionnement de l'ARRET D'URGENCE
- Vérifiez le fonctionnement de l'ARRET EN ROUE LIBRE

Mise en service de DriveWindow Light

Démarrez l'assistant (wizard) dans DriveWindow Light :

Pour une mise en service de base, enfoncez le bouton *Start* ou sélectionnez un assistant spécifique :

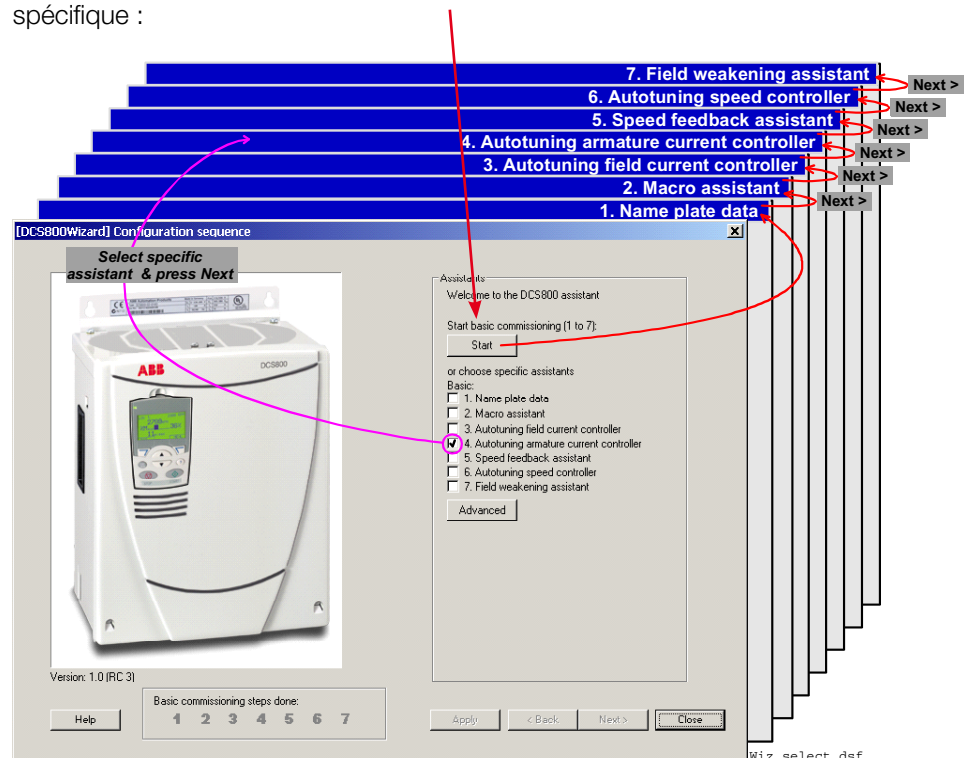
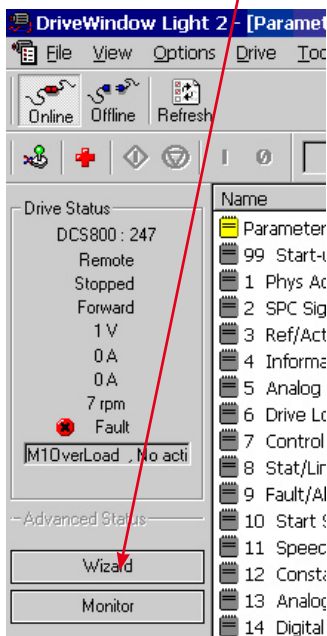

Pour en savoir plus sur l'assistant de mise en service, les paramètres, les défauts et les alarmes, cliquez sur le bouton *Help* !

Micro-console DCS800

Description succincte des touches fonctionnelles et de l'affichage de la micro-console du DCS800 (DCS CP).

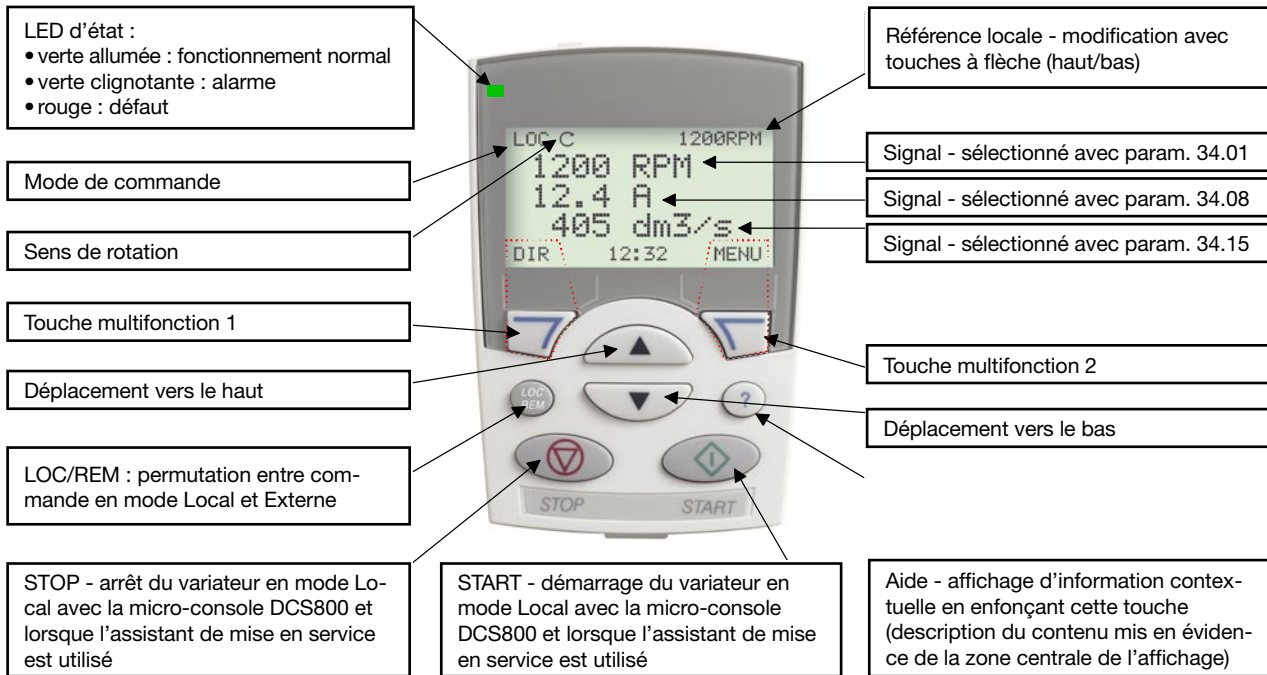

DCS800_QG_pan_ov_a.dsF

Le paramètre ListeParamètres (16.09) sert à limiter le nombre de paramètres affichés

Fonctions d'affichage

Modes accessibles dans le MENU PRINCIPAL :

1. Mode Paramètres
2. Mode Assistants de mise en service
 - a. Données de la plaque signalétique
 - b. Assistant macroprogrammes
 - c. Autocalibrage régulateur de courant d'excitation
 - d. Autocalibrage régulateur de courant d'induit
 - e. Assistant mesure vitesse (Réglage de précision tachy en préparation)
 - f. Autocalibrage régulateur de vitesse
 - g. Assistant défluxage (uniquement utilisé lorsque la vitesse maxi est supérieure à la vitesse de base)
3. Mode Macroprogrammes (en préparation)
4. Mode Paramètres modifiés (comparaison des pré-réglages usine et affichage des paramètres modifiés)
5. Mode Pile défauts (historique des défauts)
6. Mode Réglage horloge
7. Mode Sauvegarde des paramètres
 - copie des paramétrages du variateur dans la micro-console DCS800 (uniquement en mode Local)
 - copie des paramétrages de la micro-console DCS800 dans le variateur (uniquement en mode Local)
8. Mode Configuration E/S (en préparation)

Paramètres réglés par l'assistant

99.02	Tension nominale moteur 1
99.03	Courant nominal moteur 1
99.04	Vitesse de base moteur 1
20.01	Vitesse mini moteur 1
20.02	Vitesse maxi moteur 1
99.11	Courant excitation nominal moteur 1
30.09	Niveau surintensité induit
30.16	Survitesse moteur 1
99.10	Tension nominale réseau
99.12	Type excitation utilisée moteur 1
20.05	Couple maxi
20.06	Couple mini
20.12	Limite courant pont 1 moteur 1
20.13	Limite courant pont 2 moteur 1
50.04	Nombre impulsions codeur moteur 1, si sélectionné
50.02	Mode mesure codeur moteur 1, si sélectionné
50.13	Tension tachy moteur 1, DWL uniq.
50.12	Réglage tachy moteur 1, DWL uniq.
20.03	Limite vitesse nulle
22.01	Temps accélération 1
22.02	Temps décélération 1
30.12	Défaut excitation mini moteur 1
44.01	Mode régulation excitation

Dimensions, drilling patterns and weights – Abmessungen, Bohrbild und Gewichte – Dimensioni, schemi di foratura e pesi – Dimensiones, patrones de taladrado y pesos – Dimensions, perçages et poids

Module D1

DCS800-S01-0020
DCS800-S01-0045
DCS800-S01-0065
DCS800-S01-0090
DCS800-S01-0125

DCS800-S02-0025
DCS800-S02-0050
DCS800-S02-0075
DCS800-S02-0100
DCS800-S02-0140

Module D2

DCS800-S01-0180
DCS800-S01-0230

DCS800-S02-0200
DCS800-S02-0260

Module D3

DCS800-S01-0315
DCS800-S01-0405
DCS800-S01-0470

DCS800-S02-0350
DCS800-S02-0450
DCS800-S02-0520

600 V types

DCS800-S01-0290
DCS800-S02-0320

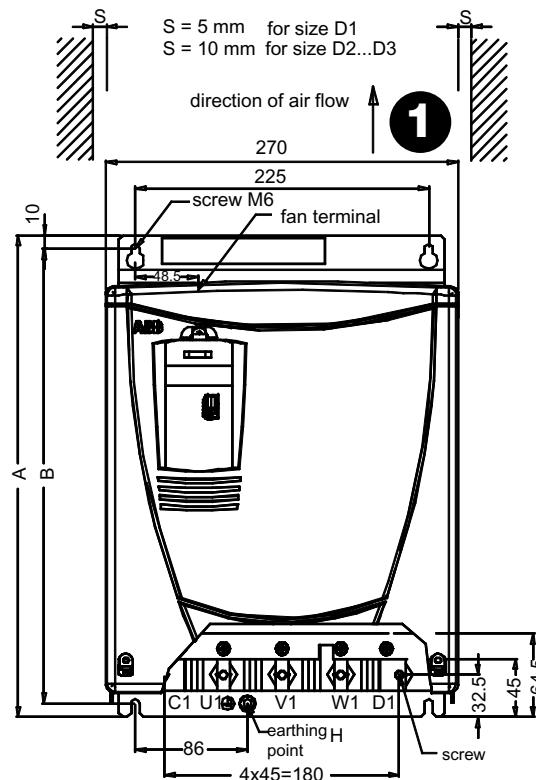

Dimensions in mm
Maße in mm
Dimensioni in mm
Dimensiones en mm
Dimensions en mm

1 Installation direction
Air direction

Montagerichtung
Luftrichtung

Direzione di installazione
Direzione aria

Modo de instalación
Dirección del aire

Sens de montage
Sens de circulation de l'air

Size	A	B	C	D	E	F	G	H	Weight
D1	370	350	142	200	67	98	145	M6	ca. 11kg
D2	370	350	209	267	121,5	163,5	212	M10	ca. 16kg
D3	459	437,5	262,5	310	147,5	205	252	M10	ca. 25kg

Data for converters with more than 1000 A (D5) see *Hardware manual*

Daten für Stromrichter mit mehr als 1000 A (D5) siehe *Hardware Handbuch*

Dati per convertitori di potenza da oltre 1000 A (D5), si veda *Hardware manual*

Datos para convertidores de más de 1.000 A (D5), véase *Hardware manual*

Données pour variateurs supérieurs à 1000 A (D5), cf. *Manuel d'installation*

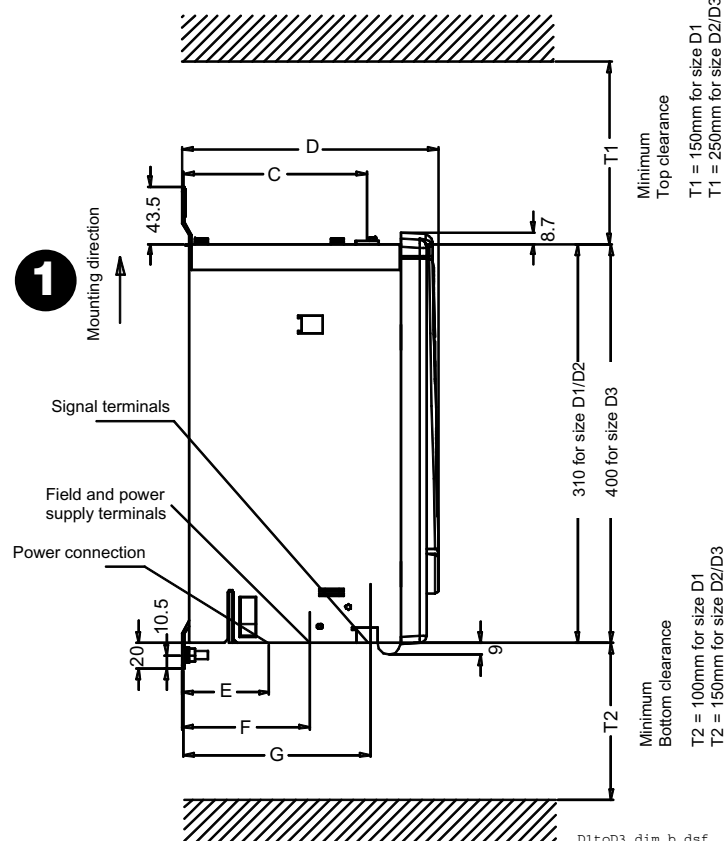

Minimum Top clearance
T1 = 150mm for size D1
T1 = 250mm for size D2/D3

Minimum Bottom clearance
T2 = 100mm for size D1
T2 = 150mm for size D2/D3

D1toD3_dim_b.dsf

Module D4

DCS800-S01-0610
DCS800-S01-0740
DCS800-S01-0900

DCS800-S02-0680
DCS800-S02-0820
DCS800-S02-1000

600 V types

DCS800-S01-0590
DCS800-S02-0650

Weight appr. 38 kg

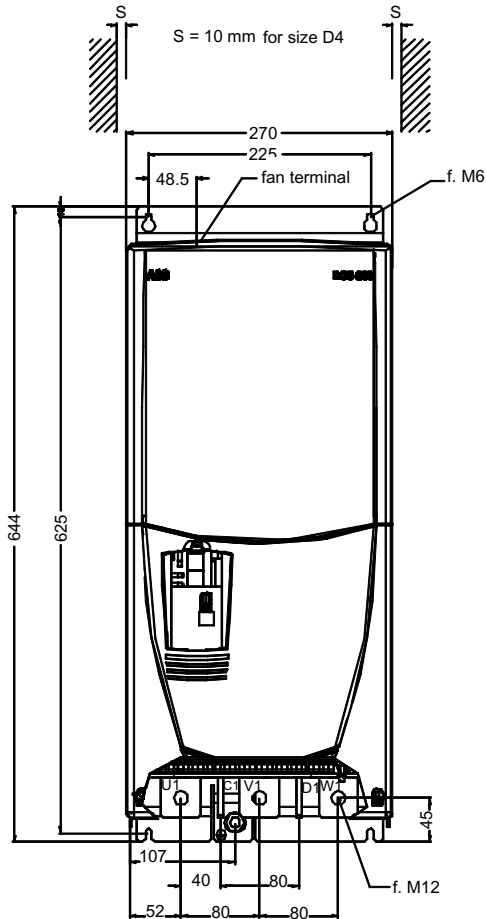

Power terminal: Busbar 40x5 mm
Weight appr. 38 kg

1 Installation direction
Air direction

Montagerichtung
Luftrichtung

Direzione di installazi-
one
Direzione aria

Modo de instalaci3n
Direcci3n del aire

Sens de montage
Sens de circulation de
l'air

Data for converters with
more than 1000 A (D5)
see *Hardware manual*

Daten f3r Stromrichter
mit mehr als 1000 A
(D5) siehe *Hardware
Handbuch*

Dati per convertitori di
potenza da oltre 1000
A (D5), si veda *Hardware
manual*

Datos para convertido-
res de m3s de 1.000 A
(D5), véase
Hardware manual

Donn3es pour variateurs
sup3rieurs 3 1000 A (D5),
cf. *Manuel d'installation*

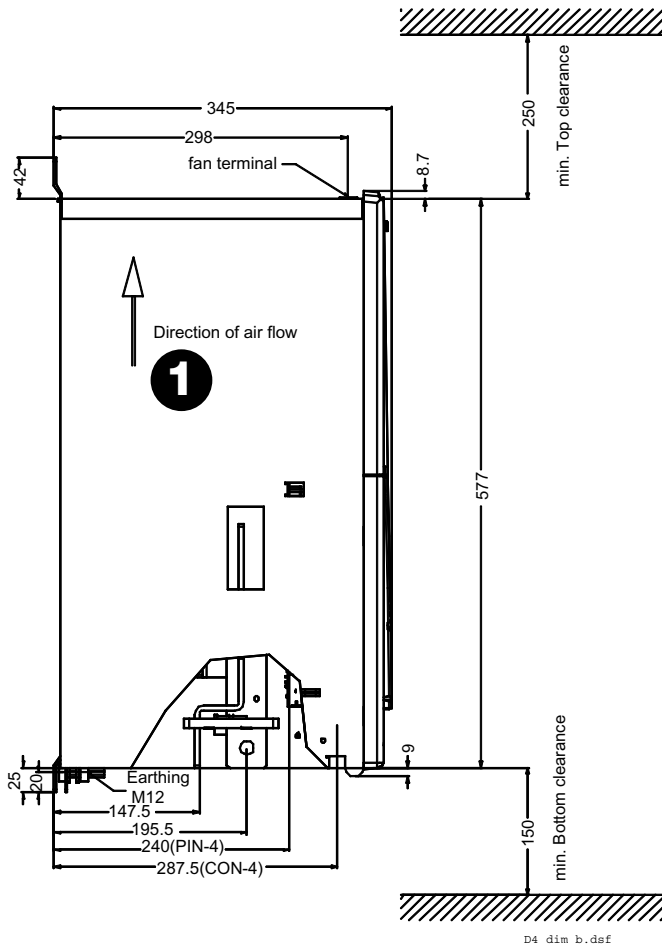

Fault / Alarm list • Fehler- / Alarmliste / ital ??? / Diagrama de la estructura del firmware / Liste des défauts et alarmes

LED	Fault Word	Text on DCS800 Panel, DriveWindow Light and DriveWindow	Text in DCS800 Pannello, DriveWindow Light und DriveWindow	Descrizione IT	Texto en el DCS800 Panel, DriveWindow Light y DriveWindow	Description FR
		Definition EN	Beschreibung D		Definición SP	
F501	9.01 Bit 0	Auxiliary undervoltage, terminal X99 on SDCS-PIN-4 and SDCS-POW-4	Hilfs-Unterspannung, Klemme X99 auf SDCS-PIN-4 und SDCS-POW-4	AuxUnderVolt Guasto tensione ausiliaria	AuxUnderVolt Fallo de tensión auxiliar (Subtension auxil.)	AuxUnderVolt Défaut tension auxiliaire
F502	9.01 Bit 1	Armature overcurrent, ArmOvrCurLev (30.09)	Überstrom Anker, ArmOvrCurLev (30.09)	ArmOverCur Sovracorrente, ArmOvrCurLev (30.09)	ArmOverCur Sobrecorriente (Sobreintensidad), ArmOvrCurLev (30.09)	ArmOverCur Surintensité, ArmOvrCurLev (30.09)
F503	9.01 Bit 2	Armature overvoltage (DC), ArmOvrVoltLev (30.08)	Überspannung Gleichstromkreis (DC), ArmOvrVoltLev (30.08)	ArmOverVolt Sovratensione d'indotto (circuito c.c.), ArmOvrVoltLev (30.08)	ArmOverVolt Sobretensión de inducido (circuito de C.C.), ArmOvrVoltLev (30.08)	ArmOverVolt Sur-tension d'induit (circuit c.c.), ArmOvrVoltLev (30.08)
F504	9.01 Bit 3	Converter overtemperature, MaxBridgeTemp (4.17)	Übertemperatur Stromrichter, MaxBridgeTemp (4.17)	ConvOverTemp Sovratempertura sezione di potenza, MaxBridgeTemp (4.17)	ConvOverTemp Sobretemperatura en la sección de potencia, MaxBridgeTemp (4.17)	ConvOverTemp Echauffement anormal du pont de puissance, MaxBridgeTemp (4.17)
F505	9.01 Bit 4	Residual current detection (ΣI differs from zero), ResCurDetectSel (30.05)	ResCurDetect Summenstromüberwachung (ΣI ungleich Null), ResCurDetectSel (30.05)	ResCurDetect Guasto a terra (ΣI diverso da zero), ResCurDetectSel (30.05)	ResCurDetect Fallo a tierra (ΣI distinto a zero), ResCurDetectSel (30.05)	ResCurDetect Défaut de terre (ΣI différent de zéro), ResCurDetectSel (30.05)
F506	9.01 Bit 5	M1OverTemp Motor 1 measured overtemperature, M1FaultLimTemp (31.07)	M1OverTemp Motor 1 gemessene Übertemperatur, M1FaultLimTemp (31.07)	M1OverTemp Motore 1 sovratemperatura, M1FaultLimTemp (31.07)	M1OverTemp Motor 1 sobretemperatura, M1FaultLimTemp (31.07)	M1OverTemp Moteur 1 echauffement anormal, M1FaultLimTemp (31.07)
F507	9.01 Bit 6	M1OverLoad Motor 1 calculated overload, M1FaultLimLoad (31.04)	M1OverLoad Motor 1 berechnete Überlast, M1FaultLimLoad (31.04)	M1OverLoad Motore 1 sovraccarico, M1FaultLimLoad (31.04)	M1OverLoad Motor 1 sobrecarga, M1FaultLimLoad (31.04)	M1OverLoad Moteur 1 surcharge, M1FaultLimLoad (31.04)
F508	9.01 Bit 7	I/OBoardLoss I/O board not found or faulty, see groups 94 and 98	I/OBoardLoss E/A-Karte nicht gefunden oder fehlerhaft, s. Gruppe 94 und 98	I/OBoardLoss	I/OBoardLoss Tarjetas E/S no encontradas o faltan, comprobar parámetros gr. 94 y 98.	I/OBoardLoss
F509	9.01 Bit 8	M2OverTemp Motor 2 measured overtemperature, M2FaultLimTemp (49.37)	M2OverTemp Motor 2 gemessene Übertemperatur, M2FaultLimTemp (49.37)	M2OverTemp Motore 2 sovratemperatura, M2FaultLimTemp (49.37)	M2OverTemp Motor 2 sobretemperatura, M2FaultLimTemp (49.37)	M2OverTemp Moteur 2 echauffement anormal, M2FaultLimTemp (49.37)
F510	9.01 Bit 9	M2OverLoad Motor 2 calculated overload, M2FaultLimLoad (49.34)	M2OverLoad Motor 2 berechnete Überlast, M2FaultLimLoad (49.34)	M2OverLoad Motore 2 sovraccarico, M2FaultLimLoad (49.34)	M2OverLoad Motor 2 sobrecarga, M2FaultLimLoad (49.34)	M2OverLoad Moteur 2 surcharge, M2FaultLimLoad (49.34)
F511	9.01 Bit 10	ConvFanCur Current converter fan not within limits, ConvTempDly (97.05)	ConvFanCur Geräteüfuerstrom nicht innerhalb der Grenzen, ConvTempDly (97.05)	ConvFanCur La corrente del ventilatore del convertitore non rientra nei limiti, ConvTempDly (97.05)	ConvFanCur Intensidad en ventilador del convertidor fuera de los límites, ConvTempDly (97.05)	ConvFanCur Courant du ventilateur du convertisseur hors limites, ConvTempDly (97.05)
F512	9.01 Bit 11	MainsLowVolt Mains low (under-) voltage (AC), UneMin1 (30.22)	MainsLowVolt Netz-Unterspannung (AC), UneMin1 (30.22)	MainsLowVolt Minima tensione di alimentazione di rete (c.a.), UneMin1 (30.22)	MainsLowVolt Tensión Baja de red (C.A.), UneMin1 (30.22)	MainsLowVolt Sous-tension réseau (c.a.), UneMin1 (30.22)

LED	Fault	Word	Text on DC5800 Panel, DriveWindow Light and DriveWindow	Text in DC5800 Panel, DriveWindow Light und DriveWindow	Testo DC5800 Pannello, DriveWindow Light e DriveWindow	Texto en el DC5800 Panel, DriveWindow Light y DriveWindow	Texte dans la DC5800 Microconsole, DriveWindow Light et DriveWindow
			Definition EN	Beschreibung D	Descrizione IT	Definición SP	Description FR
F513	9.01	Bit 12	MainsOverVolt Mains overvoltage (AC), > 1.3 * NomMainsVolt (99.10)	MainsOverVolt Netz-Überspannung (AC), > 1.3 * NomMainsVolt (99.10)	MainsOverVolt Sovratensione alimentazione di rete (c.a.), > 1.3 * NomMains Volt (99.10)	MainsOverVolt Sobretensión de red (C.A.), > 1.3 * NomMainsVolt (99.10)	MainsOverVolt Surtension réseau (c.a.), > 1.3 * NomMainsVolt (99.10)
F514	9.01	Bit 13	MainsNotSync Mains not in synchronism (AC), DevLimPLL (97.13)	MainsNotSync Netz nicht synchronisiert (AC), DevLimPLL (97.13)	MainsNotSync Guasto di sincronizzazione (c.a.), DevLimPLL (97.13)	MainsNotSync Fallo de sincronización (C.A.), DevLimPLL (97.13)	MainsNotSync Défaut de synchronisation (c.a.), DevLimPLL (97.13)
F515	9.01	Bit 14	MIFexOverCur Motor 1 field exciter overcurrent, M1FldOvrCurLev (30.13)	MIFexOverCur Motor 1 Überstrom Feldversorgung, M1FldOvrCurLev (30.13)	MIFexOverCur Motore 1 Sovracorrente ECCITATRICE DI CAMPO, M1FldOvrCurLev (30.13)	MIFexOverCur Motor 1 Sobrecorriente de la EXCITACIÓN, M1FldOvrCurLev (30.13)	MIFexOverCur Moteur 1 Surintensité EXCITATION, M1FldOvrCurLev (30.13)
F516	9.01	Bit 15	MIFexCom Motor 1 field exciter communication loss, FexTimeOut (94.07)	MIFexCom Motor 1 Kommunikationsverlust Feldversorgung, FexTimeOut (94.07)	MIFexCom Motore 1 Errore di comunicazione ECCITATRICE DI CAMPO, FexTimeOut (94.07)	MIFexCom Motor 1 Error de comunicación con la excitación, FexTimeOut (94.07)	MIFexCom Moteur 1 Erreur de communication EXCITATION, FexTimeOut (94.07)
F517	9.02	Bit 0	ArmCurRipple Armature current ripple, CurRippleSel(30.18)	ArmCurRipple Welligkeit Ankerstrom, CurRippleSel (30.18)	ArmCurRipple Ondulazione della corrente d'indotto, CurRippleSel (30.18)	ArmCurRipple Rizado de la corriente (intensidad) del inducido, CurRippleSel (30.18)	ArmCurRipple Ondulation courant d'induit, CurRippleSel (30.18)
F518	9.02	Bit 1	M2FexOverCur Motor 2 field exciter overcurrent, M2FldOvrCurLev (49.09)	M2FexOverCur Motor 2 Überstrom Feldversorgung, M2FldOvrCurLev (49.09)	M2FexOverCur Motore 2 Sovracorrente ECCITATRICE DI CAMPO, M2FldOvrCurLev (49.09)	M2FexOverCur Motor 2 Sobrecorriente de la EXCITACIÓN, M2FldOvrCurLev (49.09)	M2FexOverCur Moteur 2 Surintensité EXCITATION, M2FldOvrCurLev (49.09)
F519	9.02	Bit 2	M2FexCom Motor 2 field exciter communication loss, FexTimeOut (94.07)	M2FexCom Motor 2 Kommunikationsverlust Feldversorgung, FexTimeOut (94.07)	M2FexCom Motore 2 Errore di comunicazione ECCITATRICE DI CAMPO, FexTimeOut (94.07)	M2FexCom Motor 2 Error de comunicación con la excitación, FexTimeOut (94.07)	M2FexCom Moteur 2 Erreur de communication EXCITATION, FexTimeOut (94.07)
F521	9.02	Bit 4	FieldAck Selected motor, field acknowledge missing, Mot1FexStatus (6.12)	FieldAck Ausgewählter Motor, Rückmeldung Feldversorgung fehlt, Mot1FexStatus (6.12)	FieldAck Nessuna conferma di campo dall' ECCITATRICE DI CAMPO, Mot1FexStatus (6.12)	FieldAck EXCITACIÓN no detectada), Mot1FexStatus (6.12)	FieldAck Absence de signal retour de l'EXCITATION, Mot1FexStatus (6.12)
F522	9.02	Bit 5	SpeedFb Selected motor, speed feedback, M1SpeedFbSel (50.03)	SpeedFb Ausgewählter Motor, Drehzahlrückmeldung, M1SpeedFbSel (50.03)	SpeedFb Retroazione (misura) di velocità, M1SpeedFbSel (50.03)	SpeedFb Fallo en la lectura de la velocidad, M1SpeedFbSel (50.03)	SpeedFb Défaut retour vitesse (mesure), M1SpeedFbSel (50.03)
F523	9.02	Bit 6	ExtFanAck External fan acknowledge missing, MotFanAck (10.06)	ExtFanAck Rückmeldung externer Lüfter fehlt, MotFanAck (10.06)	ExtFanAck Nessuna conferma dal VENTILATORE del motore, MotFanAck (10.06)	ExtFanAck Sin reconocimiento del VENTILADOR del motor, MotFanAck (10.06)	ExtFanAck Absence de signal retour du VENTILATEUR du moteur, MotFanAck (10.06)
F524	9.02	Bit 7	MainContAck Main contactor acknowledge missing, MainContAck (10.21)	MainContAck Rückmeldung Hauptschutz fehlt, MainContAck (10.21)	MainContAck Manca conferma dal contattore principale, MainContAck (10.21)	MainContAck Falta reconocimiento contactor principal, MainContAck (10.21)	MainContAck Absence de signal retour du contacteur principal, MainContAck (10.21)
F525	9.02	Bit 8	TypeCode Type code mismatch, TypeCode (97.01)	TypeCode Fehlpassung Stromrichtertyp, TypeCode (97.01)	TypeCode Guasto di codifica tipo (convertitore), TypeCode (97.01)	TypeCode Fallo de identificación de Convertidor (Codificación de tipo) , TypeCode (97.01)	TypeCode Erreur d'identification du type de variateur, TypeCode (97.01)
F526	9.02	Bit 9	ExternalDI External fault via binary input, ExtFaultSel (30.31)	ExternalDI Externer Fehler an binärem Eingang, ExtFaultSel (30.31)	ExternalDI Guasto esterno su ingresso digitale, ExtFaultSel (30.31)	ExternalDI Fallo externo en la entrada digital, ExtFaultSel (30.31)	ExternalDI Défaut extérieur à l'entrée digitale, ExtFaultSel (30.31)

LED	Fault	Word	Text on DCS800 Panel, DriveWindow Light and DriveWindow	Definition EN	Beschreibung D	Text in DCS800 Panel, DriveWindow Light und DriveWindow	Descrizione IT	Definición SP	Texte dans la DCS800 Microconsole, DriveWindow Light et DriveWindow
F527	9.02	Bit 10	Converter Fan acknowledge missing, ConvFanAck (10.20)	Converter Fan acknowledge missing, ConvFanAck (10.20)	Rückmeldung Stromrichterlüfter fehlt, ConvFanAck (10.20)	Manca conferma alimentazione da VENTILATORE CONVERTITORE, ConvFanAck (10.20)	Manca conferma alimentazione da VENTILATORE CONVERTITORE, ConvFanAck (10.20)	Sin reconocimiento de la alimentación del VENTILADOR DEL CONVERTIDOR, ConvFanAck (10.20)	Absence de signal retour du VENTILATEUR du VARIATEUR, ConvFanAck (10.20)
F528	9.02	Bit 11	Fieldbus communication loss, ComLossCtrl (30.28), TimeOut (30.35)	Fieldbus communication loss, ComLossCtrl (30.28), TimeOut (30.35)	Kommunikationsfehler Feldbus, ComLossCtrl (30.28), TimeOut (30.35)	Guasto comunicazione con bus di campo, ComLossCtrl (30.28), TimeOut (30.35)	Guasto comunicación con el bus de campo, ComLossCtrl (30.28), TimeOut (30.35)	Fallo de comunicación con el bus de campo, ComLossCtrl (30.28), TimeOut (30.35)	Défaut communication avec bus de terrain, ComLossCtrl (30.28), TimeOut (30.35)
F529	9.02	Bit 12	MIFexNotOK Motor 1 field exciter not okay, hardware failure fieldexciter	MIFexNotOK Motor 1 field exciter not okay, hardware failure fieldexciter	Motor 1 Feldversorgung nicht OK, Hardwarfehler Feldversorgung	Motore 1 lo stato dell'ECCITATRICE DI CAMPO (alimentazione di campo) non è O.K.	Motor 1 lo stato dell'ECCITATRICE DI CAMPO (alimentazione di campo) non è O.K.	Motor 1: Mal estado de la unidad de EXCITACIÓN (campo)	Moteur 1 défaut EXCITATION
F530	9.02	Bit 13	M2FexNotOK Motor 2 field exciter not okay, hardware failure fieldexciter	M2FexNotOK Motor 2 field exciter not okay, hardware failure fieldexciter	Motor 2 Feldversorgung nicht OK, Hardwarfehler Feldversorgung	Motore 2 lo stato dell'ECCITATRICE DI CAMPO (alimentazione di campo) non è O.K.	Motor 2 lo stato dell'ECCITATRICE DI CAMPO (alimentazione di campo) non è O.K.	Motor 2: Mal estado de la unidad de EXCITACIÓN (campo)	Moteur 2 défaut EXCITATION
F531	9.02	Bit 14	Motor stalled, StallTime (30.01)	Motor stalled, StallTime (30.01)	Motor blockiert, StallTime (30.01)	Motore in stallo, StallTime (30.01)	Motor in stallo, StallTime (30.01)	Motor bloqueado, StallTime (30.01)	Moteur (Rotor) bloqué, StallTime (30.01)
F532	9.02	Bit 15	Motor overspeed, M1OvrSpeed (30.16)	Motor overspeed, M1OvrSpeed (30.16)	Überdrehzahl Motor, M1OvrSpeed (30.16)	Sovravelocità motore, M1OvrSpeed (30.16)	Sobrevelocidad del motor, M1OvrSpeed (30.16)	Sobrevelocidad del motor, M1OvrSpeed (30.16)	Survitesse moteur, M1OvrSpeed (30.16)
F533	9.03	Bit 0	Reversal time is elapsed, ZeroCurTimeOut (97.19), RevDly (43.14)	Reversal time is elapsed, ZeroCurTimeOut (97.19), RevDly (43.14)	Zeit Stromrichtungswechsel abgelaufen, ZeroCurTimeOut (97.19), RevDly (43.14)	Inversione direzione della corrente non O.K., ZeroCurTimeOut (97.19), RevDly (43.14)	Inversione direzione della corrente non O.K., ZeroCurTimeOut (97.19), RevDly (43.14)	Inversión de la dirección de la intensidad mal, ZeroCurTimeOut (97.19), RevDly (43.14)	Défaut d'inversion du sens du courant, ZeroCurTimeOut (97.19), RevDly (43.14)
F534	9.03	Bit 1	12-pulse current difference, DiffCurLim (47.02)	12-pulse current difference, DiffCurLim (47.02)	12-Puls Stromistwertabweichung, DiffCurLim (47.02)	Differenza in retroazione di corrente (deviazione), DiffCurLim (47.02)	Differenza in retroazione di corrente (deviazione), DiffCurLim (47.02)	Diferencia en la realimentación de la intensidad en 12 pulsos, DiffCurLim (47.02)	Ecart de retour du courant entre l'entraînement, DiffCurLim (47.02)
F535	9.03	Bit 2	12-pulse communication, 12P TimeOut (94.03)	12-pulse communication, 12P TimeOut (94.03)	12-Puls Kommunikation, 12P TimeOut (94.03)	No hay comunicación 12-pulsos, 12P TimeOut (94.03)	No hay comunicación 12-pulsos, 12P TimeOut (94.03)	No hay comunicación 12-pulsos, 12P TimeOut (94.03)	12P TimeOut (94.03)
F536	9.03	Bit 3	12-pulse slave failure. 12-pulse master is tripped by a fault of the 12-pulse slave	12-pulse slave failure. 12-pulse master is tripped by a fault of the 12-pulse slave	Fehler 12-Puls Slave. 12-Puls Master wurde wegen Fehler im 12-Puls Slave abgeschaltet	Guasto slave a 12-impulsi. Scatto del master a 12-impulsi per guasto slave a 12-impulsi	Guasto slave a 12-impulsi. Scatto del master a 12-impulsi per guasto slave a 12-impulsi	Fallo 12 pulsos esclavo. El Master es disparado por fallo en el esclavo	Défaut d'esclave 12-pulse. Maître 12-pulse déclenché dû au défaut d'esclave 12-pulse
F537	9.03	Bit 4	MIFexRdyLost Motor 1 field exciter lost ready-for-operation	MIFexRdyLost Motor 1 field exciter lost ready-for-operation	Motor 1 Feldversorgung hat die Betriebsbereitschaft verloren	MIFexRdyLost	MIFexRdyLost	MIFexRdyLost La excitación del motor 1 ha perdido estado de listo para funcionamiento	MIFexRdyLost
F538	9.03	Bit 5	M2FexRdyLost Motor 2 field exciter lost ready-for-operation	M2FexRdyLost Motor 2 field exciter lost ready-for-operation	Motor 2 Feldversorgung hat die Betriebsbereitschaft verloren	M2FexRdyLost	M2FexRdyLost	M2FexRdyLost La excitación del motor 2 ha perdido estado de listo para funcionamiento	M2FexRdyLost

LED	Fault	Word	Definition EN	Text in DC5800 Panel, DriveWindow Light and DriveWindow	Beschreibung D	Texto DC5800 Pannello, DriveWindow Light e DriveWindow	Descrizione IT	Definición SP	Texto en el DC5800 Panel, Microconsole, DriveWindow Light et DriveWindow	Description FR
F539	9.03	Bit 6	FastCurRise Actual armature current rises faster than allowed, ArmCurRiseMax (30.10)	Text in DC5800 Panel, DriveWindow Light und DriveWindow	FastCurRise Ankerstromistwert steigt schneller als erlaubt, ArmCurRiseMax (30.10)	Testo DC5800 Pannello, DriveWindow Light y DriveWindow	FastCurRise Variazione della corrente effettiva più rapida del consentito, ArmCurRiseMax (30.10)	FastCurRise La intensidad actual ha cambiado más rápido de lo permitido, ArmCurRiseMax (30.10)	FastCurRise Le courant réel varie plus vite qu'autorisé, ArmCurRiseMax (30.10)	DriveWindow Light et DriveWindow Description FR
F540	9.03	Bit 7	COMeFaulty SDCS-COM-8 faulty or not found, SysComBoard (98.16)	Text in DC5800 Panel, DriveWindow Light und DriveWindow	COMeFaulty SDCS-COM-8 fehlerhaft oder nicht gefunden, SysComBoard (98.16)	Testo DC5800 Pannello, DriveWindow Light e DriveWindow	COMeFaulty Guasto scheda SDCS-COM-8, SysComBoard (98.16)	COMeFaulty Fallo de tarjeta SDCS-COM-8 o no encontrada, SysComBoard (98.16)	COMeFaulty Défaut de la carte SDCS-COM-8, SysComBoard (98.16)	DriveWindow Description FR
F541	9.03	Bit 8	M1FexLowCur Motor 1 field exciter low current, M1FidMinTrip (30.12)	Text in DC5800 Panel, DriveWindow Light und DriveWindow	M1FexLowCur Motor 1 Unterstrom Feldversorgung, M1FidMinTrip (30.12)	Testo DC5800 Pannello, DriveWindow Light e DriveWindow	M1FexLowCur Motore 1 Sovracorrente ECCTATRICE DI CAMPO, M1FidMinTrip (30.12)	M1FexLowCur Motor 1 Sobrecorriente de la EXCITACIÓN, M1FidMinTrip (30.12)	M1FexLowCur Moteur 1 Surintensité EXCITATION, M1FidMinTrip (30.12)	DriveWindow Description FR
F542	9.03	Bit 9	M2FexLowCur Motor 2 field exciter low current, M2FidMinTrip (49.08)	Text in DC5800 Panel, DriveWindow Light und DriveWindow	M2FexLowCur Motor 2 Unterstrom Feldversorgung, M2FidMinTrip (49.08)	Testo DC5800 Pannello, DriveWindow Light e DriveWindow	M2FexLowCur Motore 2 Sovracorrente ECCTATRICE DI CAMPO, M2FidMinTrip (49.08)	M2FexLowCur Motor 2 Sobrecorriente de la EXCITACIÓN, M2FidMinTrip (49.08)	M2FexLowCur Moteur 2 Surintensité EXCITATION, M2FidMinTrip (49.08)	DriveWindow Description FR
F543	9.03	Bit 10	COMeCom Communication between SDCS-COM-8 and overriding control respectively master-follower link, Ch0ComLossCtrl (70.05), Ch2ComLossCtrl (70.15)	Text in DC5800 Panel, DriveWindow Light und DriveWindow	COMeCom Kommunikation zwischen SDCS-COM-8 und übergeordneter Steuerung bzw. Master-Follower Verbindung, Ch0ComLossCtrl (70.05), Ch2ComLossCtrl (70.15)	Testo DC5800 Pannello, DriveWindow Light e DriveWindow	COMeCom Pérdida comunicación en el lazo SDCS COM-8, PLC y Maestro Esclavo, Ch0ComLossCtrl (70.05), Ch2ComLossCtrl (70.15)	COMeCom Pérdida comunicación en el lazo SDCS COM-8, PLC y Maestro Esclavo, Ch0ComLossCtrl (70.05), Ch2ComLossCtrl (70.15)	COMeCom →, Ch0ComLossCtrl (70.05), Ch2ComLossCtrl (70.15)	DriveWindow Description FR
F544	9.03	Bit 11	P2PandMFCom Peer to peer respectively master-follower link communication, ComLossCtrl (30.28)	Text in DC5800 Panel, DriveWindow Light und DriveWindow	P2PandMFCom Kommunikation Peer to Peer bzw. Master - Follower Verbindung, ComLossCtrl (30.28)	Testo DC5800 Pannello, DriveWindow Light e DriveWindow	P2PandMFCom Pérdida en la comunicación punto a punto Maestro Esclavo, ComLossCtrl (30.28)	P2PandMFCom Pérdida en la comunicación punto a punto Maestro Esclavo, ComLossCtrl (30.28)	P2PandMFCom P2PandMFCom ComLossCtrl (30.28)	DriveWindow Description FR
F545	9.03	Bit 12	APPLoadFail Application load failure (ControlBuilder), Diagnosis (9.11)	Text in DC5800 Panel, DriveWindow Light und DriveWindow	APPLoadFail Fehler beim Laden der Applikation (ControlBuilder), Diagnosis (9.11)	Testo DC5800 Pannello, DriveWindow Light e DriveWindow	APPLoadFail Fallo en la carga de la aplicación Control Builder, Diagnosis (9.11)	APPLoadFail Fallo en la carga de la aplicación Control Builder, Diagnosis (9.11)	APPLoadFail Diagnosis (9.11)	DriveWindow Description FR
F546	9.03	Bit 13	LocalCmLoss Communication fault with panel (X33), DriveWindow (CH3) or DriveWindow Light (X34), LocalLossCtrl (30.27)	Text in DC5800 Panel, DriveWindow Light und DriveWindow	LocalCmLoss Kommunikationsfehler mit Panel (X33), DriveWindow (CH3) oder DriveWindow Light (X34), LocalLossCtrl (30.27)	Testo DC5800 Pannello, DriveWindow Light e DriveWindow	LocalCmLoss Guasto comunicazione con pannello (X33), DriveWindow (CH3) o DriveWindow Light (X34), LocalLossCtrl (30.27)	LocalCmLoss Fallo de comunicación con el Panel (X33), DriveWindow (CH3) o DriveWindow Light (X34), LocalLossCtrl (30.27)	LocalCmLoss Défaut communication avec la micro - console (X33), DriveWindow (CH3) ou DriveWindow Light (X34), LocalLossCtrl (30.27)	DriveWindow Description FR
F547	9.03	HFFailure	HFFailure Hardware failure, Diagnosis (9.11)	Text in DC5800 Panel, DriveWindow Light und DriveWindow	HFFailure Hardwarefehler, Diagnosis (9.11)	Testo DC5800 Pannello, DriveWindow Light e DriveWindow	HFFailure Guasto hardware, Diagnosis (9.11)	HFFailure Fallo hardware, Diagnosis (9.11)	HFFailure Défaut circuits, Diagnosis (9.11)	DriveWindow Description FR
F548	9.03	FwFailure	FwFailure Firmware failure, Diagnosis (9.11)	Text in DC5800 Panel, DriveWindow Light und DriveWindow	FwFailure Firmwarefehler, Diagnosis (9.11)	Testo DC5800 Pannello, DriveWindow Light e DriveWindow	FwFailure Guasto software, Diagnosis (9.11)	FwFailure Fallo software, Diagnosis (9.11)	FwFailure Défaut programme, Diagnosis (9.11)	DriveWindow Description FR
F549	9.04	ParComp	ParComp Parameter Compatibility, Diagnosis (9.11)	Text in DC5800 Panel, DriveWindow Light und DriveWindow	ParComp Parameter Kompatibilität, Diagnosis (9.11)	Testo DC5800 Pannello, DriveWindow Light e DriveWindow	ParComp Compatibilidad de parametros, Diagnosis (9.11)	ParComp Compatibilidad de parametros, Diagnosis (9.11)	ParComp Diagnosis (9.11)	DriveWindow Description FR
F550	9.04	ParMemRead	ParMemRead Parameter Memory Card read	Text in DC5800 Panel, DriveWindow Light und DriveWindow	ParMemRead Lesen Parameter Memory Card	Testo DC5800 Pannello, DriveWindow Light e DriveWindow	ParMemRead Lectura de parámetros de la Memory Card	ParMemRead Lectura de parámetros de la Memory Card	ParMemRead ParMemRead	DriveWindow Description FR

LED	Fault	Word	Text on DCS800 Panel, DriveWindow Light and DriveWindow	Definition EN	Beschreibung D	Testo DCS800 Pannello, DriveWindow Light e DriveWindow	Descrizione IT	Definición SP	Texto en el DCS800 Panel, DriveWindow Light y DriveWindow	Texte dans la DCS800 Microconsole, DriveWindow Light et DriveWindow
F551	9.04	Bit 2	AIRange Analog input range, AI/Mon4mA (30.29)	AIRange Analog input range, AI/Mon4mA (30.29)	Unterschreitung Analogeingangsbereich, AI/Mon4mA (30.29)	AIRange Mon4mA (30.29)	AIRange Mon4mA (30.29)	AIRange Rango de la entrada analógica, AI/Mon4mA (30.29)	AIRange Mon4mA (30.29)	AIRange Mon4mA (30.29)
F552	9.04	Bit 3	MechBrake Selected motor, mechanical brake, BrakeFaultFunc (42.06)	MechBrake Selected motor, mechanical brake, BrakeFaultFunc (42.06)	Ausgewählter Motor, mechanische Bremse, BrakeFaultFunc (42.06)	MechBrake BrakeFaultFunc (42.06)	MechBrake BrakeFaultFunc (42.06)	MechBrake Freno mecánico del motor, BrakeFaultFunc (42.06)	MechBrake BrakeFaultFunc (42.06)	MechBrake BrakeFaultFunc (42.06)
F553	9.04	Bit 4	TachPolarity Selected motor, tacho polarity, polarity of analog tacho signal incorrect	TachPolarity Selected motor, tacho polarity, polarity of analog tacho signal incorrect	Ausgewählter Motor, Tachopolarität, analoger Tacho verpolt	TachPolarity TachPolarity	TachPolarity TachPolarity	TachPolarity Polaridad de la señal de taco incorrecta_	TachPolarity TachPolarity	TachPolarity TachPolarity
F554	9.04	Bit 5	TachRange Selected motor, tacho range, terminals X3:1 to X3:4 on SDCS-CON-4	TachRange Selected motor, tacho range, terminals X3:1 to X3:4 on SDCS-CON-4	Ausgewählter Motor, Überschreitung Tachobereich, Klemmen X3:1 bis X3:4 auf SDCS-CON-4	TachRange TachRange	TachRange TachRange	TachRange Rango de la taco erroneo en los terminales X3:1 a X3:4 de la SDCS-CON-4	TachRange TachRange	TachRange TachRange
F556	9.04	Bit 7	TorqueProving Selected motor, torque proving, acknowledge signal is missing	TorqueProving Selected motor, torque proving, acknowledge signal is missing	Ausgewählter Motor, Drehmomentprüfung, Rückmeldesignal fehlt	TorqueProving TorqueProving	TorqueProving TorqueProving	TorqueProving Prueba de Par_	TorqueProving TorqueProving	TorqueProving TorqueProving

LED	Alarm Word	Definition EN	Beschreibung DE	Descrizione IT	Definición SP	Description FR
A101	9.06 Bit 0	Text on DCS800 Panel, DriveWindow Light and DriveWindow	Text in DCS800 Panel, DriveWindow Light und DriveWindow	Testo DCS800 Pannello, DriveWindow Light e DriveWindow	Texto en el DCS800 Panel, DriveWindow Light y DriveWindow	Texte dans la DCS800 Microconsole, DriveWindow Light et DriveWindow
A102	9.06 Bit 1	Off2 (Emergency Off / Coast stop) pending via binary input, Off2 (10.08)	Off2 (Notaus / Austrudeln) ist am einem binären Eingang aktiv, Off2 (10.08)	Off2 (10.08)	Configuración Entradas Digitales (Emergency Off / Coast stop), Off2 (10.08)	Off2 (10.08)
A103	9.06 Bit 2	Off3 (E-stop) pending via digital input, E Stop (10.09)	Off3 (Nothalt) ist am einem binären Eingang aktiv, E Stop (10.09)	Off3 (10.09), E	Configuración Entradas Digitales (E-stop), E Stop (10.09)	Off3 (10.09), E
A104	9.06 Bit 3	DCBreakAck Selected motor, DC-Breaker acknowledge missing, DCBreakAck (10.23)	DCBreakAck Ausgewählter Motor, Rückmeldung Gleichstromschnellschalter fehlt, DCBreakAck (10.23)	DCBreakAck DCBreakAck (10.23)	DCBreakAck Interruptor CC no reconocido, DCBreakAck (10.23)	DCBreakAck DCBreakAck (10.23)
A105	9.06 Bit 4	ConvOverTemp Converter overtemperature, MaxBridge Temp (4.17), ConvFanAck (10.20)	ConvOverTemp Übertemperatur Stromrichter, MaxBridge Temp (4.17), ConvFanAck (10.20)	ConvOverTemp Sovratemperatura sezione di potenza, MaxBridge Temp (4.17), ConvFanAck (10.20)	ConvOverTemp Sobretemperatura en la sección de potencia, MaxBridge Temp (4.17), ConvFanAck (10.20)	ConvOverTemp Echauffement anormal du pont de puissance, MaxBridgeTemp (4.17), ConvFanAck (10.20)
A106	9.06 Bit 5	DynBrakeAck Selected motor, dynamic braking is still pending via digital input, DynBrakeAck (10.22)	DynBrakeAck Ausgewählter Motor, Wiederstandsbremmung ist am einem digitalen Eingang aktiv, DynBrakeAck (10.22)	DynBrakeAck (10.22)	DynBrakeAck (10.22)	DynBrakeAck (10.22)
A107	9.06 Bit 6	M1OverTemp Motor 1 measured overtemperature, M1AlarmLimTemp (31.06)	M1OverTemp Motor 1 gemessene Übertemperatur, M1AlarmLimTemp (31.06)	M1OverTemp Motore 1 sovratemperatura, M1AlarmLimTemp (31.06)	M1OverTemp Motor 1 sobretemperatura, M1AlarmLimTemp (31.06)	M1OverTemp Moteur 1 échauffement anormal, M1AlarmLimTemp (31.06)
A108	9.06 Bit 7	M1OverLoad Motor 1 calculated overload, M1AlarmLimLoad (31.04)	M1OverLoad Motor 1 berechnete Überlast, M1AlarmLimLoad (31.04)	M1OverLoad Motore 1 sovraccarico, M1AlarmLimLoad (31.04)	M1OverLoad Motor 1 sobrecarga, M1AlarmLimLoad (31.04)	M1OverLoad Moteur 1 surcharge, M1AlarmLimLoad (31.04)
A109	9.06 Bit 8	M2OverTemp Motor 2 measured overtemperature, M2AlarmLimTemp (49.36)	M2OverTemp Motor 2 gemessene Übertemperatur, M2AlarmLimTemp (49.36)	M2OverTemp Motore 2 sovratemperatura, M2AlarmLimTemp (49.36)	M2OverTemp Motor 2 sobretemperatura, M2AlarmLimTemp (49.36)	M2OverTemp Moteur 2 échauffement anormal, M2AlarmLimTemp (49.36)
A110	9.06 Bit 9	M2OverLoad Motor 2 calculated overload, M2AlarmLimLoad (49.33)	M2OverLoad Motor 2 berechnete Überlast, M2AlarmLimLoad (49.33)	M2OverLoad Motore 2 sovraccarico, M2AlarmLimLoad (49.33)	M2OverLoad Motor 2 sobrecarga, M2AlarmLimLoad (49.33)	M2OverLoad Moteur 2 surcharge, M2AlarmLimLoad (49.33)
A111	9.06 Bit 10	MainsLowVolt Mains low (under-) voltage (AC), UnetMin1 (30.22)	MainsLowVolt Netz-Unterspannung (AC), UnetMin1 (30.22)	MainsLowVolt Minima tensione di alimentazione di rete (c.a.), UnetMin1 (30.22)	MainsLowVolt Bajatenション de red (C.A.), UnetMin1 (30.22)	MainsLowVolt Sous-tension réseau (AC), UnetMin1 (30.22)
A112	9.06 Bit 11	P2FanDHFCom Peer to peer respectively master-follower link communication, ComLossCtrl (30.28)	P2FanDHFCom Kommunikation Peer to Peer bzw. Master - Follower Verbindung, ComLossCtrl (30.28)	P2FanDHFCom ComLossCtrl (30.28)	P2FanDHFCom Pérdida en la comunicación punto a punto Maestro Esclavo, ComLossCtrl (30.28)	P2FanDHFCom ComLossCtrl (30.28)
A113	9.06 Bit 12	COM8Com Communication between SDCS-COM-8 and overriding control respectively master-follower link, Ch0ComLossCtrl (70.05), Ch2ComLossCtrl (70.15)	COM8Com Kommunikation zwischen SDCS-COM-8 und überordneter Steuerung bzw. Master-Follower Verbindung, Ch0ComLossCtrl (70.05), Ch2ComLossCtrl (70.15)	COM8Com ComLossCtrl (70.05), Ch2ComLossCtrl (70.15)	COM8Com Pérdida comunicación en el lazo SDCS COM-8, PLC y Maestro Esclavo, Ch0ComLossCtrl (70.05), Ch2ComLossCtrl (70.15)	COM8Com ComLossCtrl (70.05), Ch2ComLossCtrl (70.15)

LED Alarm Word	Text on DCS800 Panel, DriveWindow Light and DriveWindow	Definition EN	Text in DCS800 Panel, DriveWindow Light und DriveWindow	Beschreibung DE	Descrizione IT	Definición SP	Texte dans la DCS800 Microconsole, DriveWindow Light et DriveWindow	Description FR
A114	9.06	Bit 13 Armature current deviation, MotCur (1.06), CurRefUsed (3.12)	Text in DCS800 Panel, DriveWindow Light und DriveWindow	Ankerstrom-Abweichung, MotCur (1.06), CurRefUsed (3.12)	Deviazione corrente d'indotto, MotCur (1.06), CurRefUsed (3.12)	Desviación intensidad del inducido, MotCur (1.06), CurRefUsed (3.12)	Écart de courant d'induit, MotCur (1.06), CurRefUsed (3.12)	
A115	9.06	Bit 14 Tachorange Selected motor, tacho range, terminals X3:1 to X3:4 on SDCS-CON-4	Tachorange Ausgewählter Motor, Überschreitung Tachobereich, Klemmen X3:1 bis X3:4 on SDCS-CON-4			Rango de la tacho erroneo en los terminales X3:1 a X3:4 de la SDCS-CON-4		
A116	9.06	Bit 15 BrakeLongFalling Selected motor, mechanical brake, acknowledge signal is missing	BrakeLongFalling Ausgewählter Motor, mechanische Bremse, Rückmeldesignal fehlt			Falta señal de reconocimiento		
A117	9.07	Bit 0 Armature current ripple One or several thyristors may carry no current, CurRippleSel (30.18)	Armature current ripple Ein oder mehrere Thyristor(en) führen wahrscheinlich keinen Strom, CurRippleSel (30.18)			Freno mecánico		
A118	9.07	Bit 1 FoundNewApp1 Found new application on Memory Card, ParSave (16.06)	FoundNewApp1 Neue Applikation auf der Memory Card gefunden, ParSave (16.06)			Nueva aplicación en la Memory Card, ParSave (16.06)		
A119	9.07	Bit 2 AppIDiff Application on drive and Memory Card are different, ParSave (16.06)	AppIDiff Applikationen auf Antrieb und Memory Card sind unterschiedlich, ParSave (16.06)			Aplicación del drive y de la Memory Card no corresponden, ParSave (16.06)		
A120	9.07	Bit 3 OverVoltProt Overvoltage protection active, OvrVoltProt (10.13)	OverVoltProt Überspannungsschutz aktiv, OvrVoltProt (10.13)			Protección de sobretensión activa, OvrVoltProt (10.13)		
A121	9.07	Bit 4 AutoTuneFail Autotuning failed, Diagnosis (9.11)	AutoTuneFail Selbsteinstellung abgebrochen, Diagnosis (9.11)			Fallo durante el Autotuning, Diagnosis (9.11)		
A122	9.07	Bit 5 MechBrake Selected motor, mechanical brake, BrakeFaultFunc (42.06)	MechBrake Ausgewählter Motor, mechanische Bremse, BrakeFaultFunc (42.06)			Freno mecánico, BrakeFaultFunc (42.06)		
A123	9.07	Bit 6 FaultSuppres Fault suppressed, FaultMask (30.25)	FaultSuppres Fehler unterdrückt, FaultMask (30.25)			Fallo eliminado, FaultMask (30.25)		
A124	9.07	Bit 7 SpeedScale Speed scaling out of range, Diagnosis (9.11)	SpeedScale Drehzahlnormierung außerhalb des erlaubten Bereiches, Diagnosis (9.11)			SpeedScale Escalado interno de revoluciones fuera del rango permitido, Diagnosis (9.11)		
A125	9.07	Bit 8 SpeedFb Selected motor, speed feedback, M1SpeedFbSel (50.03)	SpeedFb Ausgewählter Motor, Drehzahlrückmeldung, M1SpeedFbSel (50.03)			SpeedFb Fallo de realimentación (medición) de velocidad, M1SpeedFbSel (50.03)		
A126	9.07	Bit 9 ExternalDI External alarm via binary input, ExtAlarmSel (30.32)	ExternalDI Externer Alarm am binären Eingang, ExtAlarmSel (30.32)			ExternalDI Alarme externo en la entrada digital, ExtAlarmSel (30.32)		

Faults & Alarms / Diagnosis

LED Alarm	Word	Definition EN	Beschreibung DE	Descrizione IT	Definición SP	Description FR
A127	9.07	Bit 10 Text on DC5800 Panel, DriveWindow Light and DriveWindow	Text in DC5800 Panel, DriveWindow Light und DriveWindow	Testo DC5800 Pannello, DriveWindow Light e DriveWindow	Texto en el DC5800 Panel, DriveWindow Light y DriveWindow	Texte dans la DC5800 Microconsole, DriveWindow Light et DriveWindow
		Definition EN	Beschreibung DE	Descrizione IT	Definición SP	Description FR
A127	9.07	Bit 10 Analog input range, AI (30.29)	Unterschreitung Analogeingangsbereich, AI (30.29)	AIRange Mon4mA (30.29)	AIRange Rango de la entrega analógica, AI Mon4mA (30.29)	AIRange Mon4mA (30.29)
A128	9.07	Bit 11 Fieldbus communication loss, ComLossCtrl (30.28), TimeOut (30.35)	FieldBusCom Kommunikationsfehler Feldbus, ComLossCtrl (30.28), TimeOut (30.35)	FieldBusCom Guasto comunicazione con bus di campo, ComLossCtrl (30.28), TimeOut (30.35)	FieldBusCom Pérdida de comunicación con el bus de campo, ComLossCtrl (30.28), TimeOut (30.35)	FieldBusCom Défaut communication avec bus de terrain, ComLossCtrl (30.28), TimeOut (30.35)
A129	9.07	Bit 12 Parameter restored	Parameter wiederhergestellt (zurückgespeichert)	ParRestored Ripristino parametri	ParRestored Parámetro restaurado	ParRestored Recupération des paramètres
A130	9.07	Bit 13 Communication fault with panel (X33), DriveWindow (CH3) or DriveWindow Light (X34), LocalLossCtrl (30.27)	LocalCmdLoss Kommunikationsfehler mit Panel (X33), DriveWindow (CH3) oder DriveWindow Light (X34), LocalLossCtrl (30.27)	LocalCmdLoss Guasto comunicazione con pannello (X33), DriveWindow (CH3) o DriveWindow Light (X34), LocalLossCtrl (30.27)	LocalCmdLoss Fallo de comunicación con el Panel (X33), DriveWindow (CH3) o DriveWindow Light (X34), LocalLossCtrl (30.27)	LocalCmdLoss Défaut communication avec la micro - console (X33), DriveWindow (CH3) ou DriveWindow Light (X34), LocalLossCtrl (30.27)
A131	9.07	Bit 14 Parameter added, Diagnosis (9.11)	Parameter hinzugeführt, Diagnosis (9.11)	ParAdded Aggiunta parametri, Diagnosis (9.11)	ParAdded Parámetros añadidos, Diagnosis (9.11)	ParAdded Paramètres ajoutés, Diagnosis (9.11)
A132	9.07	Bit 15 Parameter settings conflict, Diagnosis (9.11)	Parameter settings conflict, Diagnosis (9.11)	ParConflict Konflikt Parametereinstellung, Diagnosis (9.11)	ParConflict Conflicto en la configuración de los parámetros, Diagnosis (9.11)	ParConflict ParConflit
A133	9.08	Bit 0 Retain data invalid, backup data loaded	Retaindaten ungültig, Backupdaten wurden geladen	RetainInv RetainInv	RetainInv Datos inválidos	RetainInv RetainInv
A134	9.08	Bit 1 Parameter Compatibility, Diagnosis (9.11)	Parameter Compatibility, Diagnosis (9.11)	ParComp Diagnosis (9.11)	ParComp Compatibilidad de parámetros, Diagnosis (9.11)	ParComp Diagnosis (9.11)
A135	9.08	Bit 2 Parameter up / download failed, try again	Parameter up / download gescheitert, nochmals versuchen	ParUpDwnLoad Parameter Up / Download gescheitert, nochmals versuchen	ParUpDwnLoad Fallo durante la Carga/Descarga de parámetros	ParUpDwnLoad ParUpDwnLoad
A136	9.08	Bit 3 Adaptive program task time not set, TimeLevSel (83.04)	Adaptive Program Taskzeit nicht gesetzt, TimeLevSel (83.04)	NoAPTTaskTime TimeLevSel (83.04)	NoAPTTaskTime Programa Adaptativo, TimeLevSel (83.04)	NoAPTTaskTime TimeLevSel (83.04)
A137	9.08	Bit 4 Speed not zero, ZeroSpeedLim (20.09)	Speedzahl ist ungleich Null, ZeroSpeedLim (20.09)	SpeedNotZero ZeroSpeedLim (20.09)	SpeedNotZero Velocidad diferente a cero, ZeroSpeedLim (20.09)	SpeedNotZero ZeroSpeedLim (20.09)
A138	9.08	Bit 5 Off2 (Emergency Off / Coast stop) pending via MainCtrlWord (7.01)	Off2 (Notaus / Austrudeln) ist am pending via MainCtrlWord (7.01) aktiv	Off2FieldBus Off2 (Emergency Off / Coast stop) pending via MainCtrlWord (7.01) aktiv	Off2FieldBus Off2 Configuración Bus de Campo (Emergency Off / Coast stop), MainCtrlWord (7.01)	Off2FieldBus Off2FieldBus
A139	9.08	Bit 6 Off3 (E-stop) pending via MainCtrlWord (7.01)	Off3 (Nothalt) ist am pending via MainCtrlWord (7.01) aktiv	Off3FieldBus Off3 (E-stop) pending via MainCtrlWord (7.01) aktiv	Off3FieldBus Off3 Configuración Bus de Campo (E-stop), MainCtrlWord (7.01)	Off3FieldBus Off3FieldBus

LED	Alarm	Word	DriveWindow Light and DriveWindow	Definition EN	Beschreibung DE	DriveWindow Light e DriveWindow	Descrizione IT	DriveWindow Light y DriveWindow	Definition SP	DriveWindow Light et DriveWindow	Description FR
A140	9.08	Bit 7	Text on DCS800 Panel, DriveWindow Light and DriveWindow	Illegal fieldbus settings, see group 51	Illegale Feldbuseinstellung, s. Gruppe 51	Testo DCS800 Pannello, DriveWindow Light e DriveWindow	IllegFieldBus	Texto en el DCS800 Panel, DriveWindow Light y DriveWindow	IllegFieldBus	Texte dans la DCS800 Microconsole, DriveWindow Light et DriveWindow	IllegFieldBus
A141	9.08	Bit 8	SDCS-COM-8 firmware version conflict, FirmwareVer (4.01), Com8SwVersion (4.11)	SDCS-COM-8 Konflikt Firmwareversion, FirmwareVer (4.01), Com8SwVersion (4.11)	SDCS-COM-8 Konflikt Firmwareversion, FirmwareVer (4.01), Com8SwVersion (4.11)	FirmwareVer (4.01), Com8SwVersion (4.11)	CONFWer	Conflicto con la versión de firmware SDCS-COM-8, FirmwareVer (4.01), Com8SwVersion (4.11)	CONFWer	FirmwareVer (4.01), Com8SwVersion (4.11)	CONFWer
A142	9.08	Bit 9	Memory Card missing, ParSave (16.06)	Memory Card fehlt, ParSave (16.06)	Memory Card fehlt, ParSave (16.06)	MemCardMiss	MemCardMiss	No se encuentra Memory Card, ParSave (16.06)	MemCardMiss	MemCardMiss	MemCardMiss
A143	9.08	Bit 10	Memory Card failure, ParSave (16.06)	Fehler Memory Card, ParSave (16.06)	Fehler Memory Card, ParSave (16.06)	MemCardFail	MemCardFail	Fallo de Memory Card, ParSave (16.06)	MemCardFail	MemCardFail	MemCardFail

Diagnosis messages • Diagnose • Diagnostic 9.11

Signal	Diagnosis messages Definition EN	Diagnosemeldungen Beschreibung DE	Diagnosis messages Description IT	Diagnosis messages Definition SP	Diagnosis messages Description FR
0	no message Firmware default setting of parameters wrong	keine Meldung Firmware die Grundeinstellung der Parameter ist falsch	nessun messaggio Firmware impostazione errata dei parametri di default	no hay ningún mensaje Firmware ajuste por defecto de parámetros incorrecto	aucun message Firmware erreur pré réglage paramètres
1	parameter flash image too small for all parameters	Parameter-Flash-Image ist für alle Parameter zu klein	parameter /flash image troppo piccola per tutti i parametri	la imagen Flash de los parámetros es demasiado pequeña para todos los parámetros	image flash des paramètres trop petite pour tous les paramètres
3	reserved	reserviert	riservato	reservado	réservé
4	illegal write attempt on a write-protected parameter	???	tentativo di scrittura illecito o parametro protetto alla scrittura	???	???
5	reserved	reserviert	riservato	reservado	réservé
6	wrong type code	falscher Typeschlüssel	tipo codice errato	tipo de código incorrecto	code type erroné
7	an un-initialized interrupted has occurred	Unterbrechung aufgetreten	e avvenuto un interrupt non inizializzato	se ha producido una interrupción no inicializada	interruption non-initialisée
8,9	reserved	reserviert	riservato	reservado	réservé
10	wrong parameter value	falscher Parameterwert	valore parametro errato	valor de parámetro incorrecto	erreur valeur paramètre
11	autotuning aborted by fault or removing the Run command [UsedMCW (7.04) bit 3]	Selbsteinstellung durch Fehler oder Wegnahme des Run-Befehls [UsedMCW (7.04) Bit 3] abgebrochen	Autotatura: autotatura bloccata da un guasto o dalla rimozione del comando RUN [UsedMCW (7.04) bit 3]	Autoajuste autoajuste cancelado por fallo o al cancelar el comando Run [UsedMCW (7.04), bit 3]	Autocalibrage échec autocalibrage en raison d'un défaut ou de la disparition de la commande Marche [MCPUtilisé (7.04) bit 3]
12	autotuning timeout, RUN command [UsedMCW (7.04) bit 3] is not set in time	Selbsteinstellung Zeitüberschreitung, Run-Befehl [UsedMCW (7.04) Bit 3] wurde nicht rechtzeitig gesetzt	tempo di autotatura scaduto, comando di RUN non è attivato in tempo [UsedMCW (7.04) bit 3]	final de espera de autoajuste, no se ha ajustado el tiempo del comando RUN [UsedMCW (7.04), bit 3]	expiration du délai d'autocalibrage, la commande Marche [MCPUtilisé (7.04) bit 3] n'a pas été donnée à temps.
13	motor is still turning, no speed zero indication	Motor dreht, keine Nulldrehzahlanzeige	il motore sta ancora girando, nessuna indicazione di velocità zero	el motor continúa girando y no hay indicación de velocidad cero	le moteur encore en rotation, aucune indication de vitesse nulle
14	armature current not zero	Feldstrom nicht Null	corrente di campo non a zero	la intensidad de campo no es cero	courant d'excitation non nul
15	armature voltage measurement circuit open (e.g. not connected) or interrupted	Ankerspannungsmesskreis offen (z.B. nicht angeschlossen) oder unterbrochen, auch die Strom- und Drehmomentgrenzen prüfen	circuito di misura della tensione d'armatura aperto (es. non collegato) o interrotto, controllare anche i limiti di corrente e di coppia	la intensidad de inducido no es cero	ouverture du circuit de mesure de la tension d'induit (ex., pas connecté) ou interrompu
16	check also current and torque limits			límites de intensidad y par	Vérifier également les limites
17	armature circuit and/or armature voltage measurement circuit wrongly connected	Ankerstromkreis und/oder Ankerspannungsmesskreis falsch angeschlossen	collegamento errato del circuito d'armatura e/o del circuito di misura della tensione d'armatura	conexión incorrecta del circuito de inducido o el circuito de medición de la tensión de inducido	de courant et de couple erreur connexion circuit d'induit et/ou circuit de mesure de la tension d'induit
18	no load connected to armature circuit	keine Last an den Ankerstromkreis	nessun carico collegato al circuito d'armatura	no hay ninguna carga conectada al circuito de inducido	aucune charge connectée au circuit d'induit
19	invalid nominal armature current setting; armature current M1MotNomCur (99.03) is set to zero	ungültige Einstellung des Nennankerstroms; Ankerstrom M1MotNomCur (99.03) ist auf Null eingestellt	impostazione non valida della corrente nominale d'armatura; corrente armatura M1MotNom (99,03) è impostata a zero	ajuste incorrecto de la intensidad de inducido nominal; la intensidad de inducido M1MotNomCur (99.03) se ajusta a cero	erreur réglage courant d'induit nominal ; courant d'induit M1MotNomCur (99.03) réglé sur zéro
20	field current does not decrease when the excitation is switched off	Feldstrom verringert sich nicht, wenn die Erregung ausgeschaltet ist	La corrente di campo non diminuisce quando l'eccitazione viene disattivata	la intensidad de campo no disminuye al desconectar la excitación	le courant d'excitation ne diminue pas à la mise hors tension de l'excitation
21	field current actual doesn't reach field current reference; no detection of field resistance; field circuit open (e.g. not connected) respectively interrupted	Feldstromsollwert; keine Erkennung des Feldwiderstands; Feldstromkreis offen (z.B. nicht angeschlossen) bzw. unterbrochen	la corrente di campo reale non arriva al valore di riferimento dato; nessun rilevamento della resistenza di campo;	la intensidad actual del campo no alcanza la referencia de intensidad de campo;	le courant réel d'excitation n'atteint pas la référence du courant d'excitation, aucune résistance d'excitation détectée; ouverture circuit d'excitation (ex., pas connecté) ou interrompu
22	no writing of control parameters of speed controller	die Parameter des Drehzahlreglers werden nicht geschrieben	nessuna scrittura dei parametri di controllo del regolatore di velocità	no se ha escrito ningún parámetro de control del regulador de velocidad	pas d'écriture de paramètres de commande du régulateur de vitesse

Signal	Diagnosis messages Definition	Diagnosemeldungen Beschreibung	Diagnosis messages Descrizione	Diagnosis messages Definición	Diagnosis messages Description
9.11	EN	DE	IT	SP	FR
23	tacho adjustment faulty or not OK or the tacho voltage is too high during autotuning	Tachoeinstellung falsch oder nicht in Ordnung	Adattamento tacho difettoso o non OK o la tensione della tacho è troppo alta durante l'autotaturatura	ajuste del tacómetro incorrecto o fallido	erreur de réglage ou défaut dynamo tachymétrique
24	tuning of speed controller not possible due to speed limitation	die Abstimmung des Drehzahlreglers ist aufgrund der Drehzahlbegrenzung nicht möglich	non è possibile la taratura del regolatore di velocità a causa del limite di velocità	no es posible ajustar el regulador de velocidad debido a la limitación de velocidad	calibrage régulateur de vitesse impossible en raison des limites de vitesse
25	tuning of speed controller not possible due to voltage limitation	die Abstimmung des Drehzahlreglers ist aufgrund der Spannungsbegrenzung nicht möglich	non è possibile la taratura del regolatore di velocità a causa del limite di tensione	no es posible ajustar el regulador de tensión debido a la limitación de tensión	calibrage régulateur de vitesse impossible en raison des limites de tension
26	field weakening not allowed, see M1SpeedFbSel (50.03) and FidCtrlMode (44.01)	Feldschwächung nicht zulässig, siehe M1SpeedFbSel (50.03) und FidCtrlMode (44.01)	Indebolimento campo non permesso, vedi: M1SpeedFbSel (50.03) e FidCtrlMode (44.01)	no es posible el debilitamiento del campo; véase M1SpeedFbSel (50.03) y FidCtrlMode (44.01)	défluxage interdit; cf. <i>SéMesureVitesseM1 (50.03)</i> et <i>ModeReguleExcitat (44.01)</i>
27...30	reserved	reserviert	riservato	reservado	réservé
30	DCS800 Control Panel up- or download not started	DCS800-Steuertafel Hoch- oder Runterlesen nicht gestartet	DCS800 Control Panel up- o download non partito	no se ha iniciado la carga o descarga desde el panel de control del DCS800	chargement en lecture ou écriture micro-console DCS800 non démarré
32	DCS800 Control Panel data not up- or downloaded in time	DCS800-Steuertafel Daten werden nicht rechtzeitig Hoch- oder Runtergelesen	DCS800 Control Panel dati up- o downloadaded non in tempo	DCS800 no se han cargado o descargado a tiempo	chargement en lecture ou écriture micro-console DCS800 non effectué à temps
33	reserved	reserviert	riservato	reservado	réservé
34	DCS800 Control Panel up- or download checksum faulty	Hoch- oder Runterlesen der DCS800-Steuertafel Prüfsummenfehler	DCS800 Control Panel up- o download controllo di parità difettoso	fallo de la suma de comprobación de la carga o descarga en el panel de control del DCS800	erreur du total de contrôle chargement en lecture ou écriture micro-console DCS800
35	DCS800 Control Panel up- or download software faulty	Hoch- oder Runterlesen der DCS800-Steuertafel Software fehlerhaft	DCS800 Control Panel up- o download software difettoso	fallo del software de carga o descarga en el panel de control del DCS800	erreur du logiciel chargement en lecture ou écriture micro-console DCS800
36	DCS800 Control Panel up- or download verification failed	Hoch- oder Runterlesen der DCS800-Steuertafel Verifizierung misslungen	DCS800 Control Panel up- or download verifica fallita	fallo de la verificación de la carga o descarga en el panel de control del DCS800	echec verification chargement en lecture ou écriture micro-console DCS800
37...49	reserved	reserviert	riservato	reservado	réservé
50	parameter flash faulty (erase)	Hardware Parameter Flash fehlerhaft (löschen)	Hardware Parameter flash difettosa (cancellata)	Hardware Parameter flash incorrecto (borrar)	Matériel Flash paramètres défectueuse (en effacement)
51	parameter flash faulty (program)	Hardware Parameter Flash fehlerhaft (Programm)	Hardware Parameter flash difettosa (programma)	Hardware Parameter FLASH incorrecto (programa)	Flash paramètres défectueuse (en programmation)
52...69	reserved	reserviert	riservato	reservado	réservé
70	A132 ParConflict (alarm parameter setting conflict); reserved	Konflikt: Parameter für die Flusslinearisierung nicht konsistent	A132 ParConflict (conflitto impostazione parametro allarme); riservato	AT132 ParConflict (conflicto en el ajuste de los parámetros de alarma); reservado	A132 ConflitParam (alarme de conflit de réglages de paramètres); réserve
71	flux linearization parameters not consistent	Parameter für die Flusslinearisierung nicht konsistent	parametri di linearizzazione flusso non coerenti	parámetros de linealización de flujo contradictorios	incohérence paramètres de flux de linéarisation
72	reserved	reserviert	riservato	reservado	réservé
73	armature data not consistent [e.g. TypeCode (97.01) = None and S ConvScaleVolt (97.03) is not set properly or ConvNomVolt (4.04) = 0]	Parameterüberlauf	Dati armatura non coerenti [es. TypeCode (97.01) = Nessuno e S ConvScaleVolt (97.03) non è impostato correttamente o ConvNomVolt (4.04) = 0]	desbordamiento de parámetros	valeur paramètres hors limites
74...79	reserved	reserviert	riservato	reservado	réservé
80	Autotuning speed does not reach setpoint (EMF control)	Hardware Selbststellung Drehzahl erreicht nicht den Sollwert (EMK-Regelung)	Autotatura: la velocità non raggiunge il setpoint (controllo EMF)	Autoajuste la velocidad no alcanza el punto de consigna (control EMF)	Autocalibrage la vitesse n'atteint pas la consigne (régulation FEM)
81	motor is not accelerating or wrong tacho polarity (tacho / encoder)	Motor beschleunigt nicht oder falsche Tachopolarität (Tacho / Impulsgeber)	Il motore non sta accelerando o la polarità tacho è sbagliata (tacho/encoder)	tacómetro es incorrecta (tacómetro/generador de pulsos)	polarité dynamo tachymétrique (dynamo tachymétrique/codeur)
82	not enough load (too low inertia) for the detection of speed controller parameters	unzureichende Last (Trägheitsmoment zu gering) für die Erkennung der Drehzahlreglerparameter	Carico non sufficiente (inerzia troppo bassa) per rilevare i parametri del regolatore di velocità	no hay suficiente carga (inercia demasiado baja) para la detección de los parámetros del regulador de velocidad	charge insuffisante (inertie trop faible) pour détecter les paramètres du régulateur de vitesse
83...89	reserved	reserviert	riservato	reservado	réservé
90	Thyristor diagnosis shortcircuit caused by V1	Hardware Thyristordiagnose Kurzschluss verursacht durch V1	Diagnosi Thyristor cortocircuito causato da V1	Diagnostico del tristor cortocircuito causado por V1	Diagnostic des thyristors court-circuit provoqué par V1
91	shortcut caused by V2	Kurzschluss verursacht durch V2	cortocircuito causato da V2	cortocircuito causado por V2	court-circuit provoqué par V2
92	shortcut caused by V3	Kurzschluss verursacht durch V3	cortocircuito causato da V3	cortocircuito causado por V3	court-circuit provoqué par V3

Signal	Diagnosis messages Definition	Diagnosemeldungen Beschreibung	Diagnosis messages Descrizione	Diagnosis messages Definición	Diagnosis messages Description
93	shortcut caused by V4	Kurzschluss verursacht durch V4	cortocircuito causado da V4	cortocircuito causado por V4	court-circuit provoqué par V4
94	shortcut caused by V5	Kurzschluss verursacht durch V5	cortocircuito causado da V5	cortocircuito causado por V5	court-circuit provoqué par V5
95	shortcut caused by V6	Kurzschluss verursacht durch V6	cortocircuito causado da V6	cortocircuito causado por V6	court-circuit provoqué par V6
96	thyristor block test failed	Thyristorblockierertest misslungen	test blocco thyristor fallito	prueba del bloque de tiristores fallida	défaut test bloc thyristors
97	shortcut caused by V15 or V22	Kurzschluss verursacht durch V15 oder V22	cortocircuito causado da V15 o V22	cortocircuito causado por V15 o V22	court-circuit provoqué par V15 ou V22
98	shortcut caused by V16 or V23	Kurzschluss verursacht durch V16 oder V23	cortocircuito causado da V16 o V23	cortocircuito causado por V16 o V23	court-circuit provoqué par V16 ou V23
99	shortcut caused by V11 or V24	Kurzschluss verursacht durch V11 oder V24	cortocircuito causado da V11 o V24	cortocircuito causado por V11 o V24	court-circuit provoqué par V11 ou V24
100	shortcut caused by V12 or V25	Kurzschluss verursacht durch V12 oder V25	cortocircuito causado da V12 o V25	cortocircuito causado por V12 o V25	court-circuit provoqué par V12 ou V25
101	shortcut caused by V13 or V26	Kurzschluss verursacht durch V13 oder V26	cortocircuito causado da V13 o V26	cortocircuito causado por V13 o V26	court-circuit provoqué par V13 ou V26
102	shortcut caused by V14 or V21	Kurzschluss verursacht durch V14 oder V21	cortocircuito causado da V14 o V21	cortocircuito causado por V14 o V21	court-circuit provoqué par V14 ou V21
103	motor connected to ground	Motor an Masse kurzgeschlossen	motore collegato a terra	motor conectado a tierra	moteur raccordé à la terre
104	armature winding is not connected	Ankerwicklung ist nicht angeschlossen	avvolgimento d'armatura non collegato	el bobinado de inducido no está conectado	enroulement d'induit non raccordé
105...120	reserved	reserviert	riservato	reservado	réservé
121	AI monitoring	AI Überwachung	controllo AI	Monitorización de EA	Surveillance Entrée analogique (EA)
122	AI1 below 4 mA	AI1 unter 4 mA	AI1 inferiore a 4 mA	EA1 inferior a 4 mA	EA1 inférieure à 4 mA
123	AI2 below 4 mA	AI2 unter 4 mA	AI2 inferiore a 4 mA	EA2 inferior a 4 mA	EA2 inférieure à 4 mA
124	AI3 below 4 mA	AI3 unter 4 mA	AI3 inferiore a 4 mA	EA3 inferior a 4 mA	EA3 inférieure à 4 mA
125	AI4 below 4 mA	AI4 unter 4 mA	AI4 inferiore a 4 mA	EA4 inferior a 4 mA	EA4 inférieure à 4 mA
126	AI5 below 4 mA	AI5 unter 4 mA	AI5 inferiore a 4 mA	EA5 inferior a 4 mA	EA5 inférieure à 4 mA
127	AI6 below 4 mA	AI6 unter 4 mA	AI6 inferiore a 4 mA	EA6 inferior a 4 mA	EA6 inférieure à 4 mA
128...149	reserved	reserviert	riservato	AI7AC inferior a 4 mA	EA7AC inférieure à 4 mA
150	Option modules	Optionsmodule	Moduli opzionali:	Modulos opcionales	Modules optionnels
151	fieldbus module missing see <i>CommModule (98.02)</i>	Fieldbusmodul fehlt siehe <i>CommModule (98.02)</i>	modulo fieldbus mancante vedere <i>CommModule (98.02)</i>	módulo de bus de campo ausente; véase <i>CommModule (98.02)</i>	coupleur réseau absent cf. <i>ModuleCommunic (98.02)</i>
152	SDCS-COM-8 for DDCS- respectively fieldbus communication missing see <i>CommModule (98.02)</i>	SDCS-COM-8 für DDCS- bzw. Feldbuskommunikation fehlt, siehe <i>CommModule (98.02)</i>	SDCS-COM-8 per DDCS- persa comunicazione del rispettivo fieldbus vedi <i>CommModule (98.02)</i>	SDCS-COM-8 para la comunicación maestro-esclavo ausente; véase el grupo 70	SDCS-COM-8 pour communication Maître/esclave absente, cf. groupe 70
153	reserved	reserviert	riservato	reservado	réservé
154	RMBA-xx module missing see group 98	RMBA-xx Modul fehlt, siehe Gruppe 98	modulo RMBA-xx mancante vedi gruppo 98	modulo RMBA-xx ausente; véase el grupo 98	module RMBA-xx absent, cf. groupe 98
155	RAIO-xx in option slot on SDCS-CON-4 missing see group 98	RAIO-xx in Optionssteckplatz auf SDCS-CON-4 fehlt, siehe Gruppe 98	RAIO-xx mancante nello slot sulla SDCS-CON-4 vedi gruppo 98	RAIO-xx ausente en la ranura de módulos opcionales de SDCS-CON-4; véase el grupo 98	RAIO-xx absent dans support pour option de la SDCS-CON-4, cf. groupe 98
156	RAIO-xx in option slot on AIMA missing see group 98	RAIO-xx in Optionssteckplatz auf AIMA fehlt, siehe Gruppe 98	RAIO-xx mancante nello slot sulla AIMA vedi gruppo 98	RAIO-xx ausente en la ranura de módulos opcionales de AIMA; véase el grupo 98	RAIO-xx absent dans support pour option de la carte AIMA, cf. groupe 98
157	RDIO-xx in option slot on SDCS-CON-4 missing see group 98	RDIO-xx in Optionssteckplatz auf SDCS-CON-4 fehlt, siehe Gruppe 98	RDIO-xx mancante nello slot sulla SDCS-CON-4 vedi gruppo 98	RDIO-xx ausente en la ranura de módulos opcionales de SDCS-CON-4; véase el grupo 98	RDIO-xx absent dans support pour option de la SDCS-CON-4, cf. groupe 98
158	RDIO-xx in option slot on AIMA missing see group 98	RDIO-xx in Optionssteckplatz auf AIMA fehlt, siehe Gruppe 98	RDIO-xx mancante nello slot sulla AIMA vedi gruppo 98	RDIO-xx ausente en la ranura de módulos opcionales de AIMA; véase el grupo 98	RDIO-xx absent dans support pour option de la carte AIMA, cf. groupe 98
159	RTAC-xx in option slot on SDCS-CON-4 missing see group 98	RTAC-xx in Optionssteckplatz auf SDCS-CON-4 fehlt, siehe Gruppe 98	RTAC-xx mancante nello slot sulla SDCS-CON-4 vedi gruppo 98	RTAC-xx ausente en la ranura de módulos opcionales de SDCS-CON-4; véase el grupo 98	RTAC-xx absent dans support pour option de la SDCS-CON-4, cf. groupe 98
160	RTAC-xx in option slot on AIMA missing see group 98	RTAC-xx in Optionssteckplatz auf AIMA fehlt, siehe Gruppe 98	RTAC-xx mancante nello slot sulla AIMA vedi gruppo 98	RTAC-xx ausente en la ranura de módulos opcionales de AIMA; véase el grupo 98	RTAC-xx absent sur un support de la carte AIMA, cf. groupe 98
161	reserved	reserviert	riservato	reservado	réservé

Signal	Diagnosis messages Definition	Diagnosemeldungen Beschreibung	Diagnosis messages Descrizione	Diagnosis messages Definición	Diagnosis messages Description
9.11	EN	DE	IT	SP	FR
162	SDCS-IOB-2x respectively SDCS-IOB-3 connection does not match selection in IO BoardConfig (98.15)	SDCS-IOB2x bzw. SDCS-IOB-3 Anschluss entspricht nicht der Auswahl in IO BoardConfig (98.15)	SDCS-IOB-2x e rispettiva connessione SDCS-IOB-3 non si accordano alla selezione nel IO BoardConfig (98.15)	la conexión de SDCS-IOB2x o SDCS-IOB-3 no concuerda con la selección de IO BoardConfig (98.15)	le raccordement de la carte SDCS-IOB2x ou SDCS-IOB-3 ne correspond pas à la sélection faite au paramètre ConfigCarte F/S (98.15)
163	SDCS-DSL-4 missing see group 94 (needed for DCSLink)	SDCS-DSL-4 fehlt, siehe Gruppe 94 (für DCSLink benötigt)	SDCS-DSL-4 mancante vedi gruppo 94 (necessaria per DCSLink)	SDCS-DSL-4 ausente; véase el grupo 94 (necesario para DCSLink)	SDCS-DSL-4 absente, cf. groupe 94 (requis pour DCSLink)
164	SDCS-DSL-4 missing see group 94 (needed for Modbus)	SDCS-DSL-4 fehlt, siehe Gruppe 94 (für Modbus benötigt)	SDCS-DSL-4 mancante vedi gruppo 94 (necessaria per Modbus)	SDCS-DSL-4 ausente; véase el grupo 94 (necesario para Modbus)	SDCS-DSL-4 absente, cf. groupe 94 (requis pour Modbus)
	A134 ParComp (alarm parameter compatibility conflict):	A134 ParComp (Alarm Parameter-Kompatibilität):	A134 ParComp (allarme per conflitto di compatibilità parametro)	A134 ParComp (conflicto de compatibilidad de los parámetros de alarma):	A134 CompatiPara (alarme conflit compatibilité paramètres):
10000...	the parameter with the compatibility conflict can be identified by means of the last 4 digits	der Parameter mit dem Kompatibilitätskonflikt kann anhand der letzten vier Ziffern ermittelt werden	Il parametro con conflitto di compatibilità può essere identificato per mezzo degli ultimi 4 digits	el parámetro que presenta el conflicto de compatibilidad puede identificarse mediante sus últimas cuatro cifras	le paramètre à l'origine du conflit est identifié par les 4 derniers chiffres.
30000	Thyristor diagnosis	Thyristordiagnose	Diagnosti Thyristor	Diagnostico del tiristor	Diagnostic thyristors
31x0d	possibly trigger pulse channels are mixed up	eventuell sind die Zündimpulskanäle vertauscht	possibilità che siano scambiati i canali che danno l'impulso di trigger	es posible que los canales del pulso de activación no sean los correctos	commande d'impulsions éventuellement inversées
32x0d	V1 or V12 not conducting	V1 oder V12 leitet nicht	V1 o V12 non sta conducendo	V1 o V12 han cesado de conducir	V1 ou V12 non conducteur
33x0d	V2 or V13 not conducting	V2 oder V13 leitet nicht	V2 o V13 non sta conducendo	V2 o V13 han cesado de conducir	V2 ou V13 non conducteur
34x0d	V3 or V14 not conducting	V3 oder V14 leitet nicht	V3 o V14 non sta conducendo	V3 o V14 han cesado de conducir	V3 ou V14 non conducteur
35x0d	V4 or V15 not conducting	V4 oder V15 leitet nicht	V4 o V15 non sta conducendo	V4 o V15 han cesado de conducir	V4 ou V15 non conducteur
36x0d	V5 or V16 not conducting	V5 oder V16 leitet nicht	V5 o V16 non sta conducendo	V5 o V16 han cesado de conducir	V5 ou V16 non conducteur
	x = 0: only a single thyristor in bridge 1	x = 0: nur ein einzelner Thyristor in Brücke 1	x = 0: un solo thyristor nel ponte 1	x = 0: solamente un tiristor del puente	x = 0 : seul un thyristor du pont 1 n'est pas conducteur (par ex., 320dd = V2 ou V12 non conducteur)
	is not conducting (e.g. 320dd means V2 respectively V12 is not conducting)	in Brücke 1 leitet nicht (z.B. 320dd bedeutet, dass V2 bzw. V12 nicht leiten)	conduce (es. 320dd significa che V2 o rispettivamente V12 non conduce)	1 ha cesado de conducir (p. ej. 320dd significa que V2 o V12 han dejado de conducir)	V12 non conducteur
	x = 1 ... 6: additionally a second thyristor in bridge 1 is no conducting (e.g. 325dd means V2 and V5 respectively V12 and V15 are not conducting)	x = 1 ... 6: darüber hinaus leitet ein zweiter Thyristor in Brücke 1 nicht (z.B. 325dd bedeutet, dass V2 und V5 bzw. V12 und V15 nicht leiten)	x = 1 ... 6: in aggiunta un secondo thyristor nel ponte 1 non conduce (es. 325dd significa che V2 e V5 o rispettivamente V12 e V15 non conducono)	1 n'est pas conducteur (par ex., 325dd = V2 et V5 ou V12 et V15 non conducteurs)	1 n'est pas conducteur (par ex., 325dd = V2 et V5 ou V12 et V15 non conducteurs)
	dd = don't care, the numbers of this digits do not carry any information about the thyristors of the first bridge.	dd = don't care, diese Ziffern enthalten keine Informationen über die Thyristoren der ersten Brücke.	dd = non considerare, i numeri di questi digits non portano alcuna informazione circa i thyristors del primo ponte.	dd = carecen de importancia. Estos números no aportan ninguna información sobre los tiristores del primer puente.	dd = sans importance, ces chiffres ne contiennent aucune information sur les thyristors du premier pont.
	Example: 36030: means V16 in bridge 1 and V23 in bridge 2 are not conducting	Beispiel: 36030: bedeutet, dass V16 in Brücke 1 und V23 in Brücke 2 nicht leiten	esempio: 36030: significa V16 nel ponte 1 e V23 nel ponte 2 non conducono	Ejemplo: 36030: significa que V16, en el puente 1, y V23, en el puente 2, ya no conducen	Exemple : 36030= V16 (pont 1) et V23 (pont 2) non conducteurs
3dd1v	V21 not conducting	V21 leitet nicht	V21 non sta conducendo	V21 ha cesado de conducir	V21 non conducteur
3dd2v	V22 not conducting	V22 leitet nicht	V22 non sta conducendo	V22 ha cesado de conducir	V22 non conducteur
3dd3v	V23 not conducting	V23 leitet nicht	V23 non sta conducendo	V23 ha cesado de conducir	V23 non conducteur
3dd4v	V24 not conducting	V24 leitet nicht	V24 non sta conducendo	V24 ha cesado de conducir	V24 non conducteur
3dd5v	V25 not conducting	V25 leitet nicht	V25 non sta conducendo	V25 ha cesado de conducir	V25 non conducteur
3dd6v	V26 not conducting	V26 leitet nicht	V26 non sta conducendo	V26 ha cesado de conducir	V26 non conducteur

Signal	Diagnosis messages Definition	Diagnosemeldungen Beschreibung	Diagnosis messages Descrizione	Diagnosis messages Definición	Diagnosis messages Description
9.11	EN y = 0: only a single thyristor in bridge 2 is not conducting (e.g. 3dd0020 means V22 is not conducting) y = 1 ... 6: additionally a second thyristor in bridge 2 is no conducting (e.g. 3dd25 means V22 and V25 are not conducting) dd = don't care, the numbers of this digits do not carry any information about the thyristors of the second bridge. Example: 36030: means V16 in bridge 1 and V23 in bridge 2 are not conducting	DE y = 0: nur ein einzelner Thyristor in Brücke 2 leitet nicht (z.B. 3dd0020 bedeutet, dass V22 nicht leitet) y = 1 ... 6: darüber hinaus leitet ein zweiter Thyristor in Brücke 2 nicht (z.B. 3dd25 bedeutet, dass V22 und V25 nicht leiten) dd = don't care, diese Ziffern enthalten keine Informationen über die Thyristoren der ersten Brücke. Beispiel: 36030: bedeutet, dass V16 in Brücke 1 und V23 in Brücke 2 nicht leiten	IT y = 0: un solo thyristor nel ponte 2 non conduce (es. 3dd0020 significa che V22 non conduce) y = 1 ... 6: in aggiunta un secondo thyristor nel ponte 2 non conduce (es. 3dd25 significa che V22 e V25 non conducono) dd = non considerare, i numeri di questi digits non portano alcuna informazione circa i thyristors del secondo ponte. esempio: 36030: significa V16 nel ponte 1 e V23 nel ponte 2 non conducono	SP y = 0: solamente un tiristor del puente 2 ha cesado de conducir (p. ej. 3dd0020 significa que V22 ha dejado de conducir) y = 1 ... 6: adicionalmente, un segundo tiristor del puente 2 ha cesado de conducir (p. ej. 3dd25 significa que V22 y V25 han dejado de conducir) dd = carecen de importancia. Estos números no aportan ninguna información sobre los tiristores del segundo puente. Ejemplo: 36030: significa que V16, en el puente 1, y V23, en el puente 2, ya no conducen de velocidad).	FR y = 0 : seul un thyristor du pont 2 n'est pas conducteur (par ex., 3dd0020 = V22 non conducteur) y = 1 ... 6 : un second thyristor du pont 2 n'est pas conducteur (par ex., 3dd25 = V22 et V25 non conducteurs) dd = sans importance, ces chiffres ne contiennent aucune information sur les thyristors du second pont. Exemple : 36030= V16 (pont 1) et V23 (pont 2) non conducteurs
40000 ... 49999	A124 SpeedScale (alarm speed scaling): the parameter with the speed scaling conflict can be identified by means of the last 4 digits	A124 SpeedScale (Alarm Drehzahlnormierung): der Parameter mit dem Konflikt in der Drehzahlnormierung kann anhand der letzten vier Ziffern ermittelt werden	A124 SpeedScale (allarme scalatura velocità): il parametro con conflitto scalatura velocità può essere identificato per mezzo degli ultimi 4 digits	A124 SpeedScale (alarma del escalado de velocidad): el parámetro que presenta el conflicto de escalado de velocidad puede identificarse mediante sus últimas cuatro cifras	A124 ErrFormatVlt (alarma échelle de vitesse): le paramètre à l'origine du conflit est identifié par les 4 derniers chiffres.
50000 ... 59999	F549 ParComp (fault parameter compatibility conflict): the parameter with the compatibility conflict can be identified by means of the last 4 digits	F549 ParComp (Fehler Parameter Kompatibilität): Kompatibilitätskonflikt kann anhand der letzten vier Ziffern ermittelt werden	F549 ParComp (guasto per incompatibilità parametro): il parametro con conflitti di compatibilità può essere identificato per mezzo degli ultimi 4 digit	F549 ParComp (fallo de conflicto de compatibilidad de parámetros): el parámetro que presenta el conflicto de compatibilidad puede identificarse mediante sus últimas cuatro cifras	F549 CompatibPara (défaut conflit compatibilité paramètres): le paramètre à l'origine du conflit est identifié par les 4 derniers chiffres.
	F545 ApplLoadFail (ControlBuilder DCS800 application programming): task not configured attempt to run an illegal copy of a protected program retain data invalid caused by SDCS-CON-4 hardware problem	F545 ApplLoadFail (ControlBuilder DCS800 Applikationsprogrammierung): Zykluszeit nicht konfiguriert Versuch, eine illegale Kopie eines geschützten Programms auszuführen gesicherte Daten auf der SDCS-CON-4 sind durch ein Hardwareproblem ungültig	F545 ApplLoadFail (programma applicativo Control Builder DCS800): task non configurata tentativo di attivare una copia illegale di un programma protetto dati non validi trattenuti a causa di problema ardware della SDCS-CON-4	F545 ApplLoadFail (programación de aplicaciones para el DCS800 con ControlBuilder): tarea no configurada se ha intentado ejecutar una copia ilegal de un programa protegido se conservan los datos no válidos causados por el problema de hardware de SDCS-CON-4	F545 DéfChargAppl (programme d'application ControlBuilder DCS800): tâche non configurée tentative d'exécution d'une copie interdite d'un programme protégé copie de données erronée en raison d'un problème matériel de la carte SDCS-CON-4
64120 64121	5 ms task halted (e.g. task contains an endless loop) 20 ms task halted (e.g. task contains an endless loop)	5 ms Zykluszeit angehalten (z.B. Zykluszeit enthält eine Endlosschleife) 20 ms Zykluszeit angehalten (z.B. Zykluszeit enthält eine Endlosschleife)	task 5 ms bloccata (es. la task contiene un endless loop) task 20 ms bloccata (es. la task contiene un endless loop)	tarea de 5 ms detenida (p. ej. la tarea contiene un bucle infinito) tarea de 20 ms detenida (p. ej. la tarea contiene un bucle infinito)	tâche arrêtée pendant 5 ms (ex., la tâche comporte une boucle infinie) tâche arrêtée pendant 20 ms (ex., la tâche comporte une boucle infinie)
64122	100 ms task halted (e.g. task contains an endless loop)	100 ms Zykluszeit angehalten (z.B. Zykluszeit enthält eine Endlosschleife)	task 100 ms bloccata (es. la task contiene un endless loop)	tarea de 100 ms detenida (p. ej. la tarea contiene un bucle infinito)	tâche arrêtée pendant 100 ms (ex., la tâche comporte une boucle infinie)
64123	500 ms task halted (e.g. task contains an endless loop)	500 ms Zykluszeit angehalten (z.B. Zykluszeit enthält eine Endlosschleife)	task 500 ms bloccata (es. la task contiene un endless loop)	tarea de 500 ms detenida (p. ej. la tarea contiene un bucle infinito)	tâche arrêtée pendant 500 ms (ex., la tâche comporte une boucle infinie)

Macro & Firmware structure / Makro & Firmware Struktur / Struttura macro & firmware / Estructura del macro & firmware / Structure du logiciel macro & système

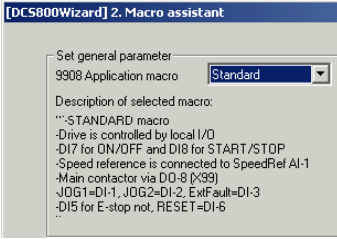

Standard

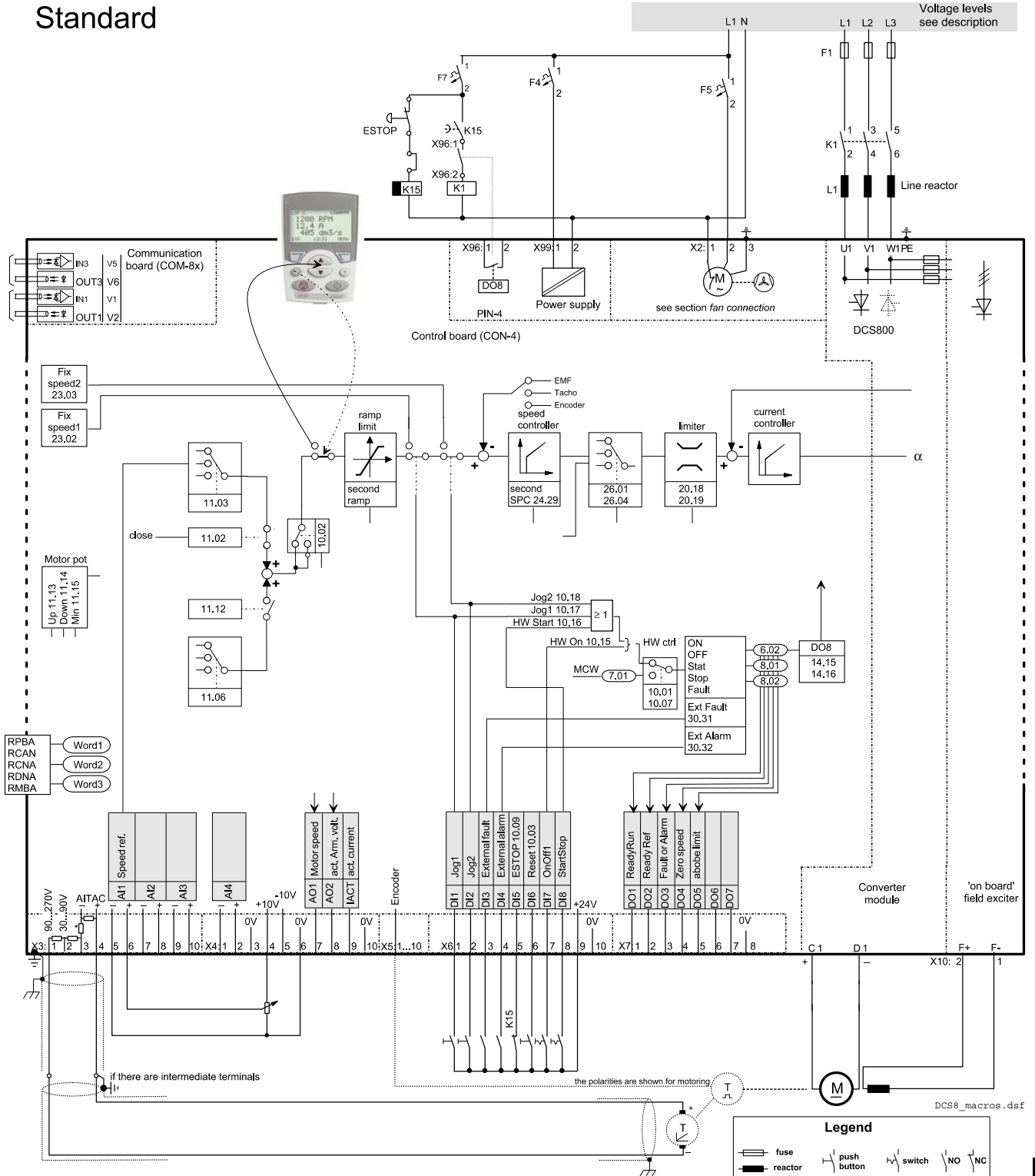

[DCS800Wizard] 2. Macro assistant

Set general parameter
 9908 Application macro **2WireDCcontUS**

Description of selected macro:
 - STANDARD macro + DC contactor
 - Drive is controlled by local I/O
 - D17 for ON/OFF and D18 for START/STOP (2 wire)
 - Speed reference is connected to SpeedRef AI-1
 - DC contactor [US] via D0-8 (K39)
 - JOG1=D1-1, JOG2=D1-2, ExtFault=D1-3
 - D15 for E-stop not, RESET=D1-6

2-wireDCcontUS

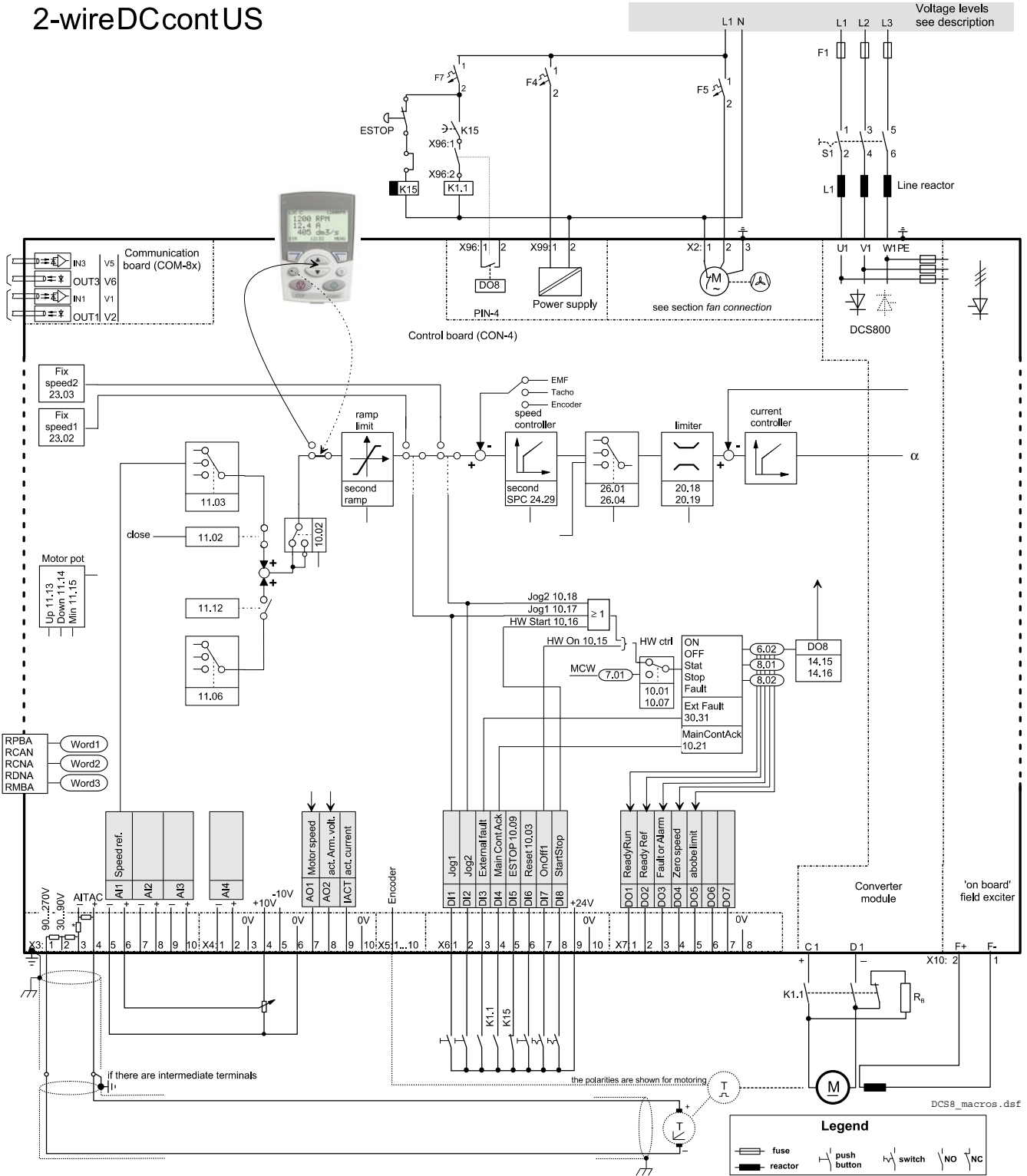

[DCS800Wizard] 2. Macro assistant

Set general parameter:
 9908 Application macro: **3WireDCcontUS**

Description of selected macro:
 - STANDARD macro + DC contactor + (3 wire cont)
 - Drive is controlled by local I/O
 - ON/start pulse DI-7 and OFF/stop pulse (NC) DI-8
 - Speed reference is connected to SpeedRef AI-1
 - DC contactor (US) via DO-8 (X39)
 - Jog1=DI-1, Jog2=DI-2, ExtFault=DI-3
 - DI5 for E-stop not, RESET=DI-6

3-wireDCcont US

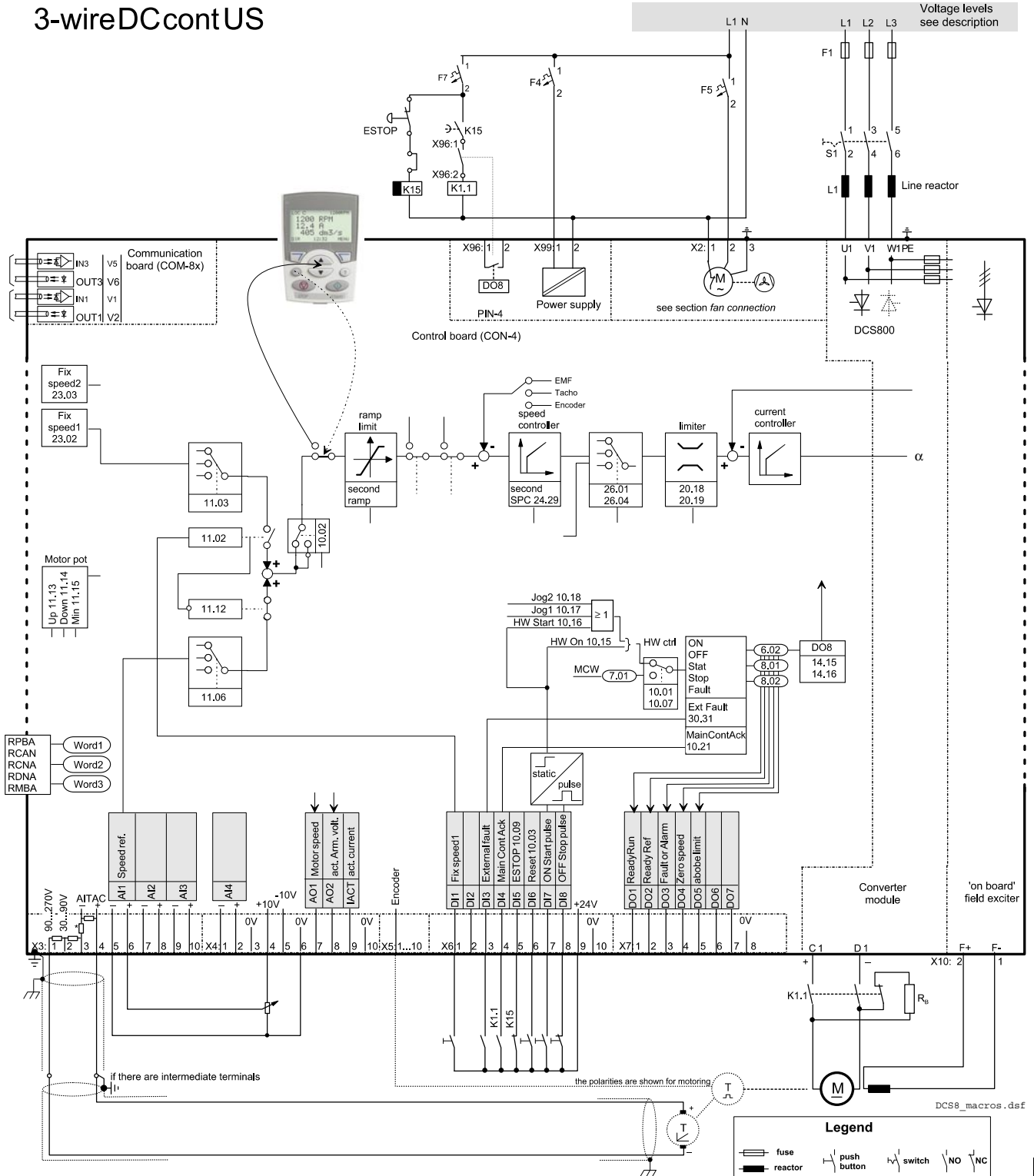

[DCS800Wizard] 2. Macro assistant

Set general parameter
 9908 Application macro **3WireStandard**

Description of selected macro:
 "" STANDARD macro + 3 wire control
 - Drive is controlled by local I/O
 - ON/start pulse DI-7 and OFF/ stop pulse (NC) DI-8
 - DN/start pulse DI-7 and OFF/ stop pulse (NC) DI-8
 - Speed reference is connected to SpeedRef AI-1
 - Main contactor via DO-8 (x99)
 - JDI1=DI-1, JDI2=DI-2, ExtFault=DI-3
 - DI5 for E-stop not, RESET=DI-6

3-wire Standard

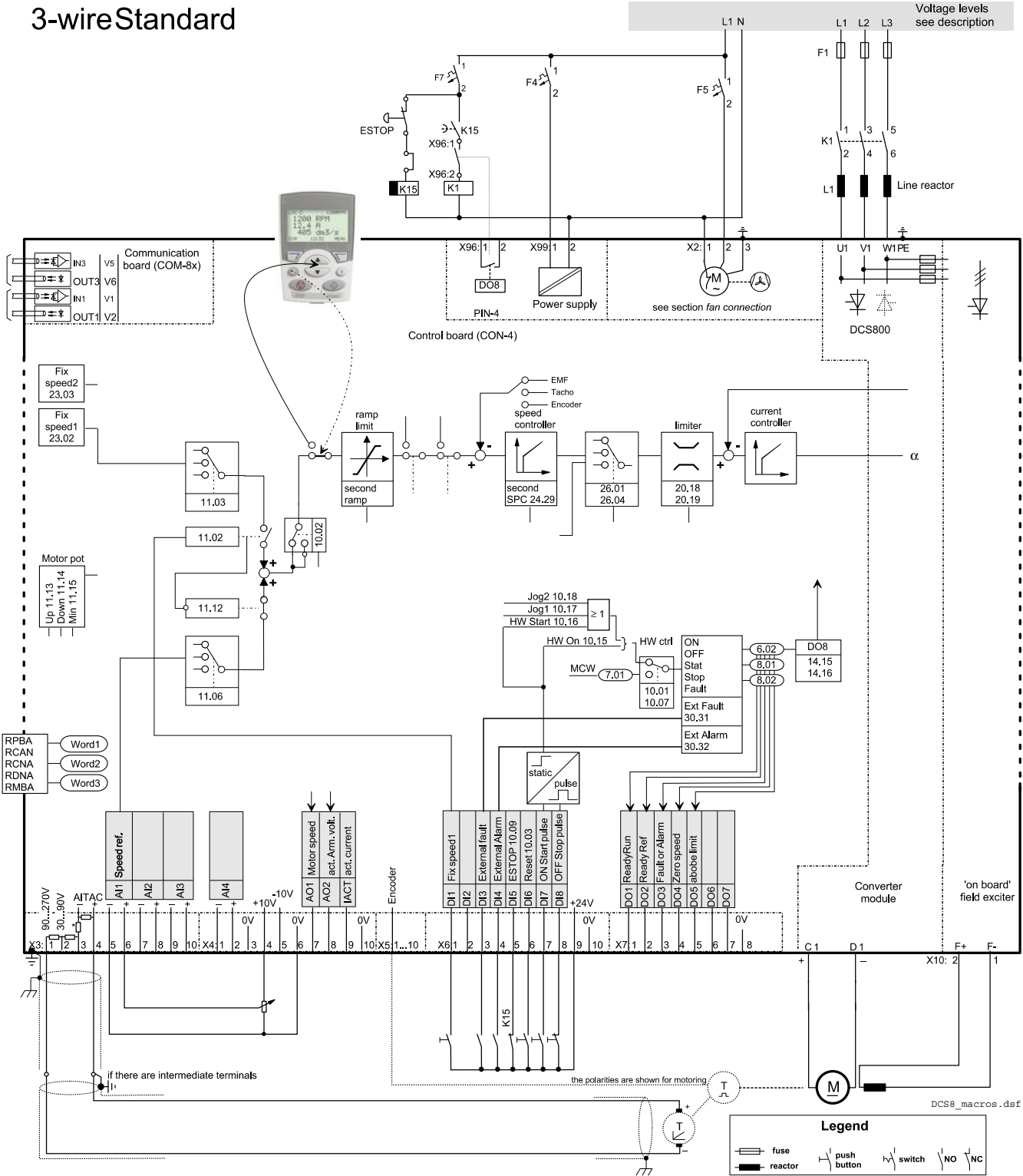

[DCS800Wizard] 2. Macro assistant

Set general parameter
 9908 Application macro **TorqLimit**

Description of selected macro:
 - S1 ANDAHD macro + torque limit = AI-2
 - Drive is controlled by local I/O
 - D17 for ON/OFF and D18 for START/STOP
 - Speed reference is connected to SpeedRef AI-1
 - Main contactor via DO-8 (X39)
 - JOG1=D1-1, JOG2=D1-2, ExtFault=D1-3
 - D1-5 for E-stop not, RESET=D1-6

Torquelimit

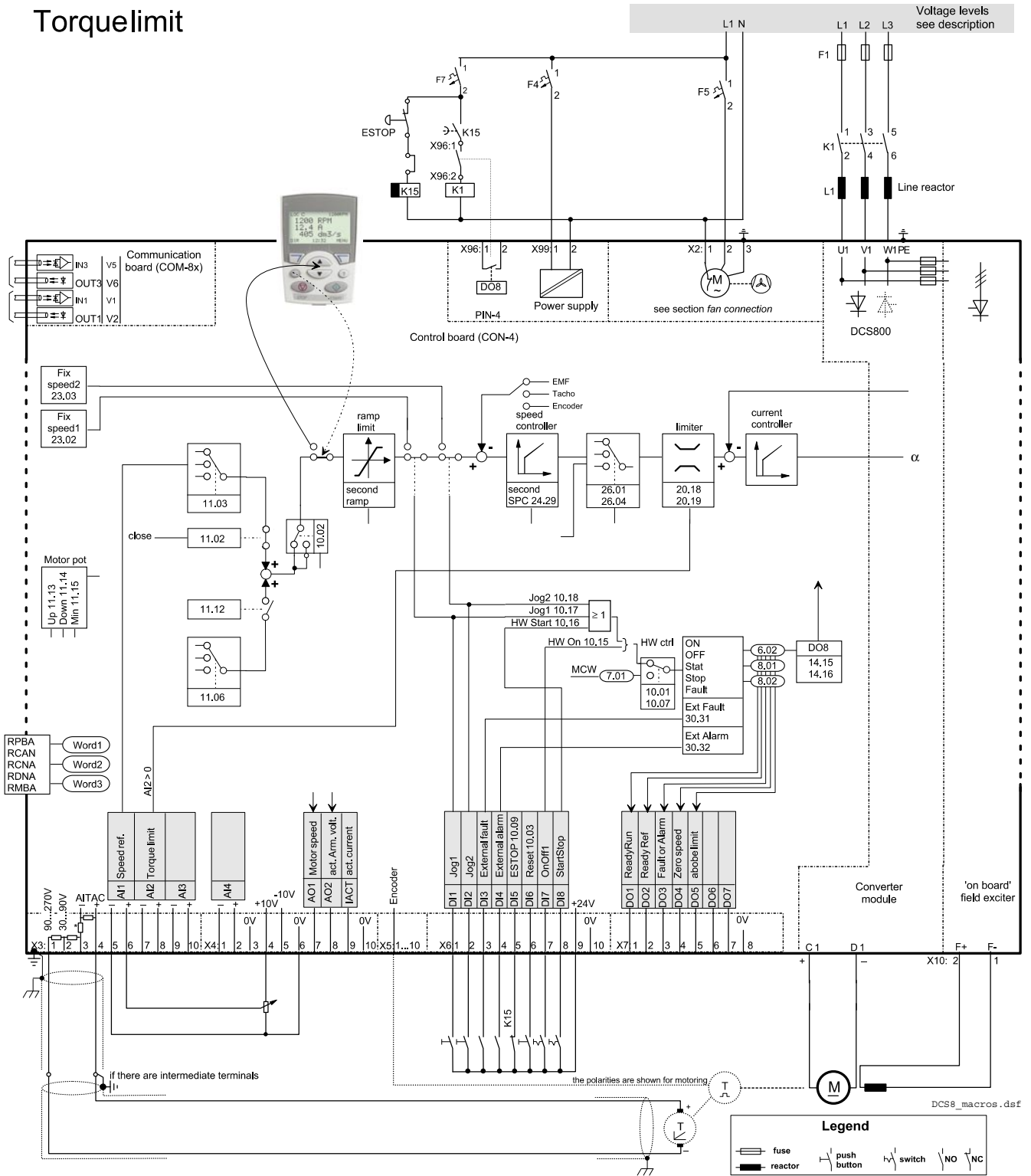

[DCS800Wizard] 2. Macro assistant

Set general parameter
 9908 Application macro **Man/Const**

Description of selected macro:
 - Manual / constant speed [motor pot] macro
 - Drive is controlled by local I/O
 - DN/start pulse DI-7 and OFF/ stop pulse DI-8
 - Speed reference AI-1 or motor pot (DI-1 = mux)
 - Main contactor via DO-8 (x39)
 - JOG1=DI-1, JOG2=DI-2, direction=DI-3
 - DI-5 for E-stop not, RESET=DI-6

Man/Const

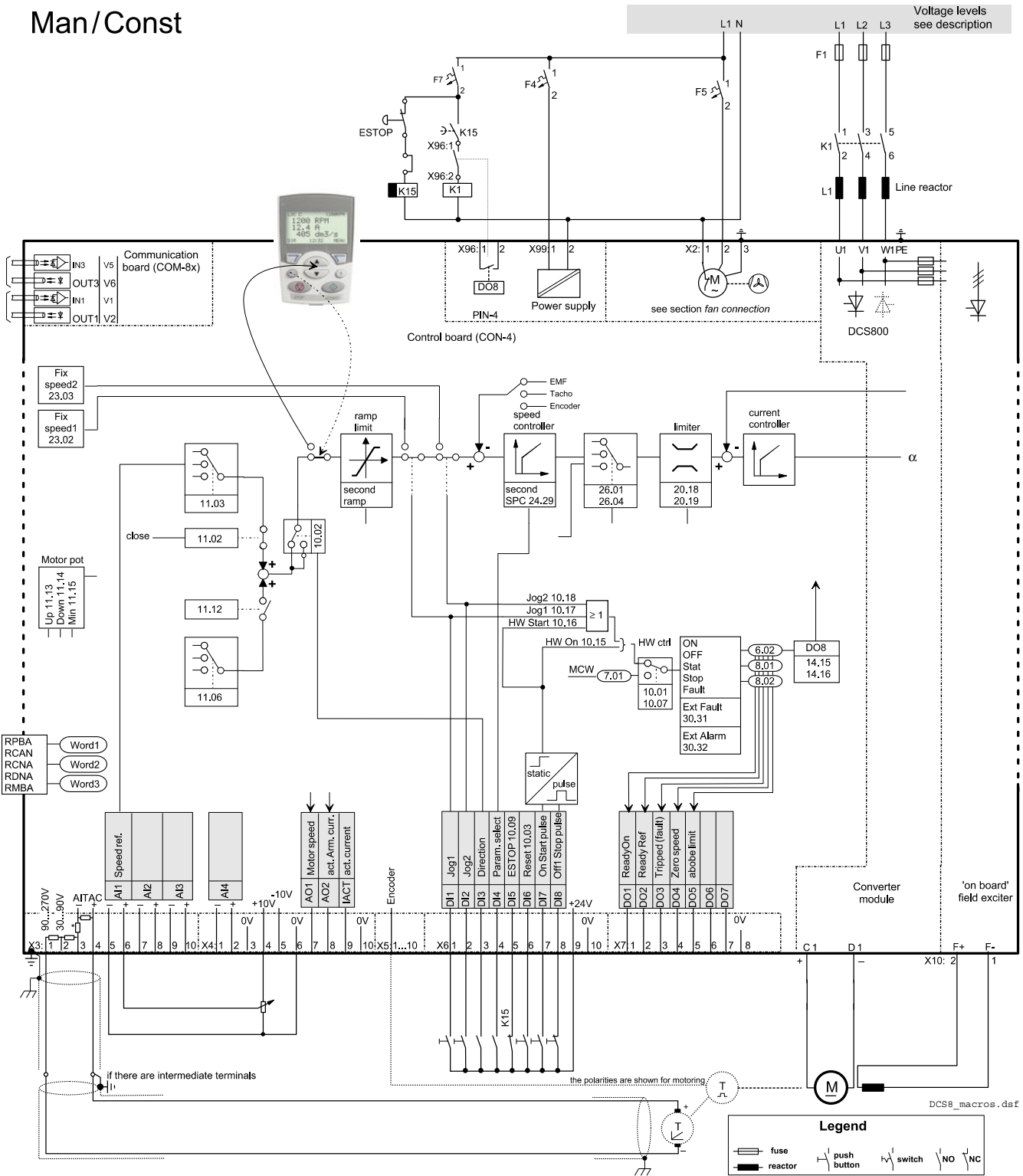

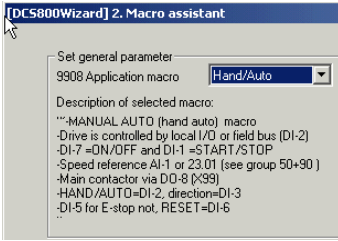

Hand/Auto

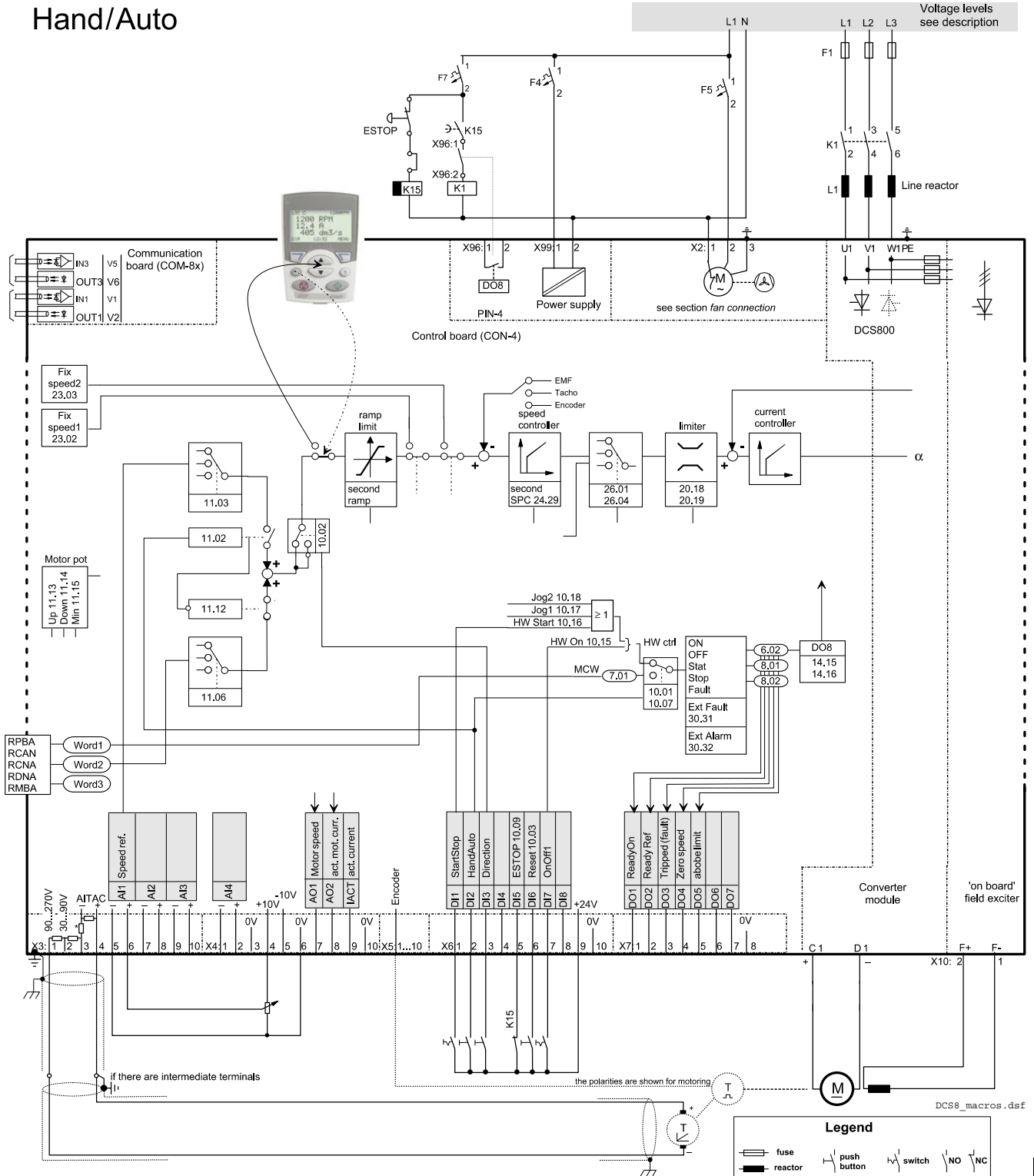

[DCS800Wizard] 2. Macro assistant

Set general parameter
 9908 Application macro **Hand/MotPot**

Description of selected macro:
 ""-HAND /Motor potentiometer macro (stop=no rest)
 -Drive is controlled by local I/O
 -DN/start pulse DI-7 and OFF/ stop pulse (NC) DI-8
 -Speed reference by motor pot or AI-1 (DI-4= max)
 -Main contactor via DO-8 (X39)
 -Speed up =DI-1, speed down=DI-2 direction=DI-3
 -DI-5 for E-stop not, RESET=DI-6

Hand/MotPot

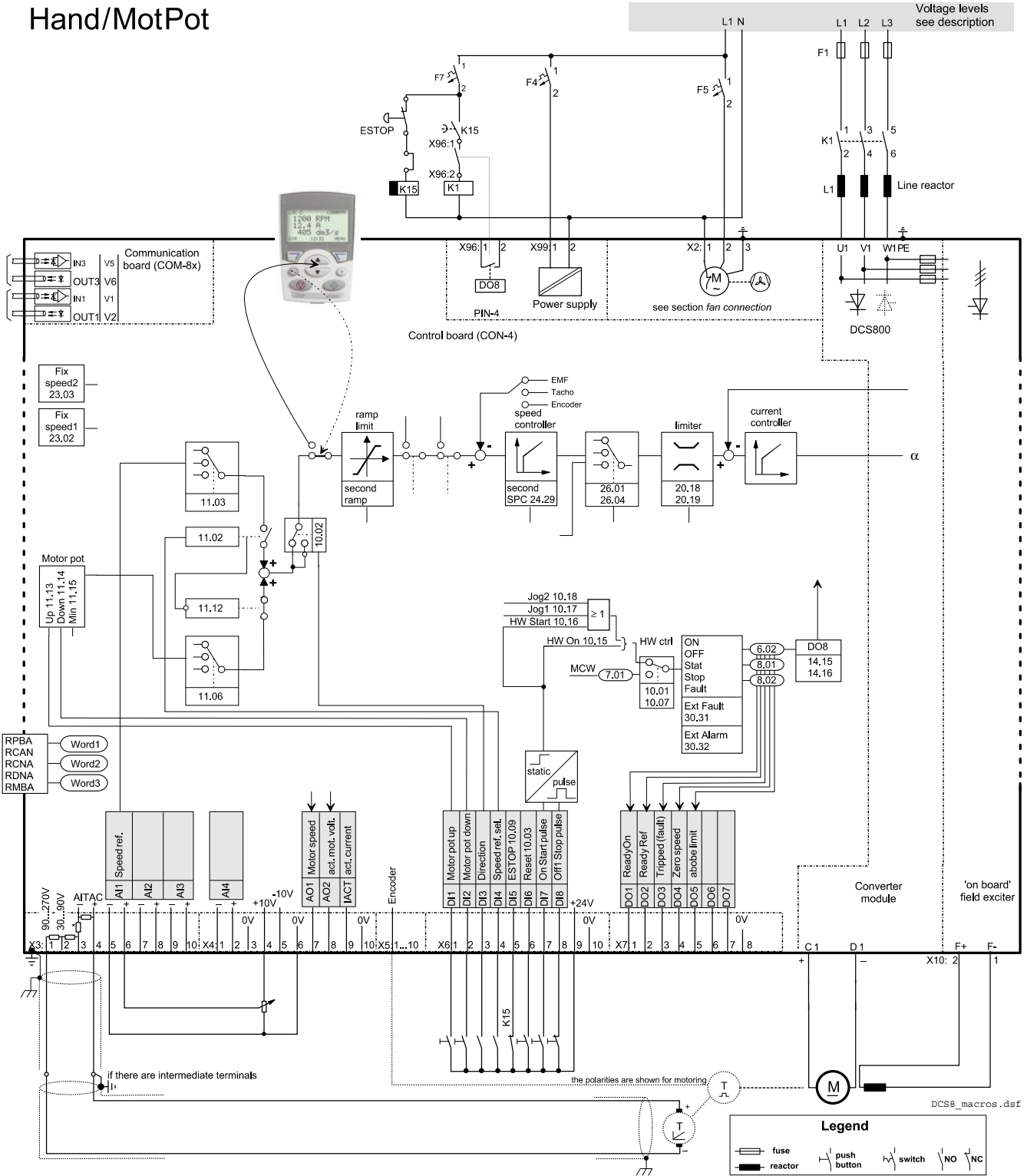

[DCS800Wizard] 2. Macro assistant

Set general parameter
 9908 Application macro: **MotorPot**

Description of selected macro:
 - Motor potentiometer macro (stop no reset)
 - Drive is controlled by local I/O
 - DI7 for ON/OFF and DI8 for START/STOP
 - Speed reference by motor pot
 - Main contactor via DO-8 (x39)
 - Direction =DI-1, Speed up =DI-2, speed down=DI-3
 - DI5 for E-stop not, RESET=DI-6

MotorPot

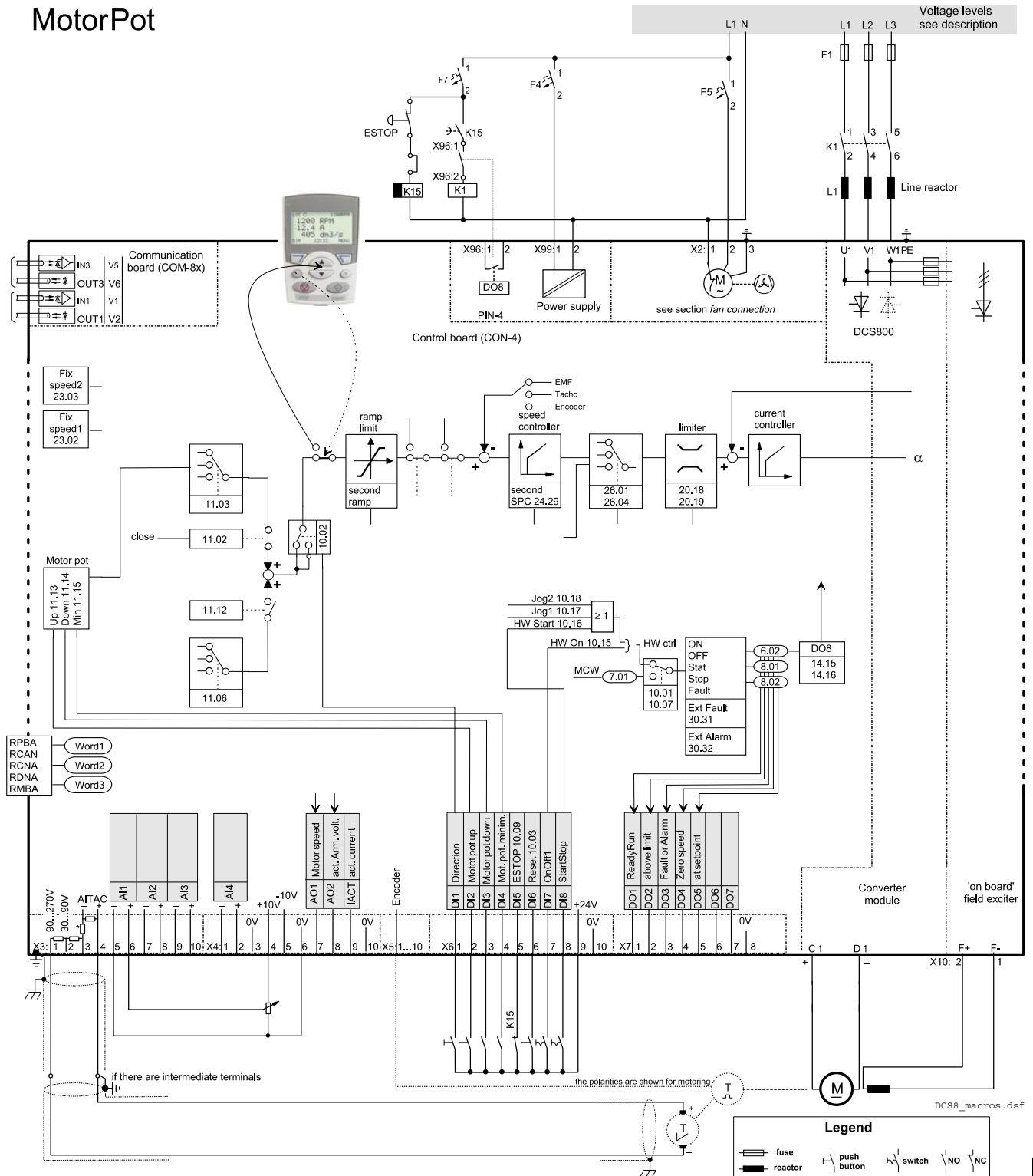

[DCS800Wizard] 2. Macro assistant

Set general parameter
 9908 Application macro: **TorcCtrl**

Description of selected macro:
 - Torque control macro
 - Drive is controlled by local I/O
 - DI7 for ON/DOFF and DI8 for START/STOP
 - Torque or speed reference AI-1 (DI-2=aux)
 - Main contactor via DO-8 (DI-2=aux)
 - ExtFault=DI-3, RESET=DI-6
 - DI4 for DI2 not (start inhibition), DI5 for E-stop not"

TorcCtrl

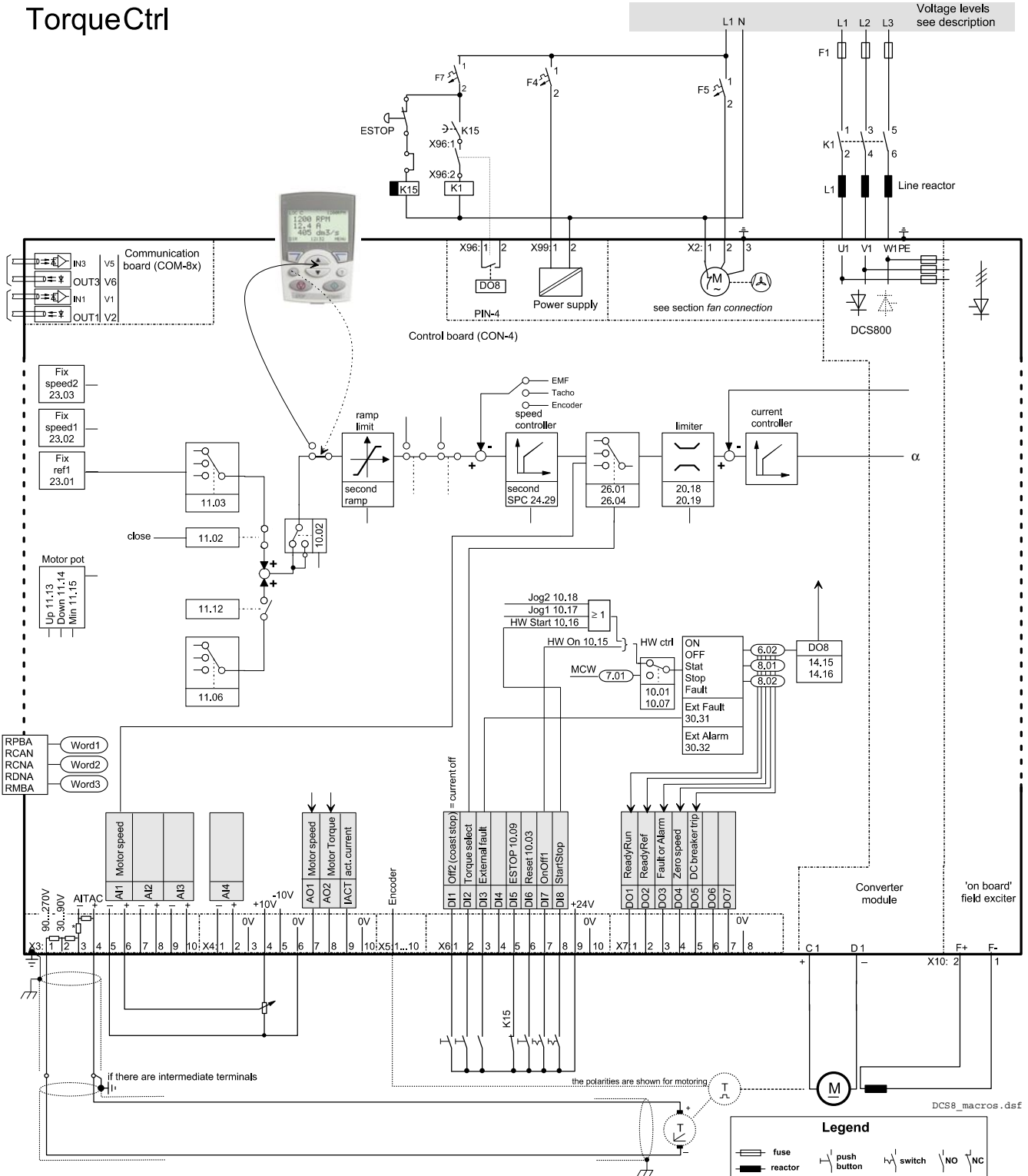

SPEED REFERENCE CHAIN

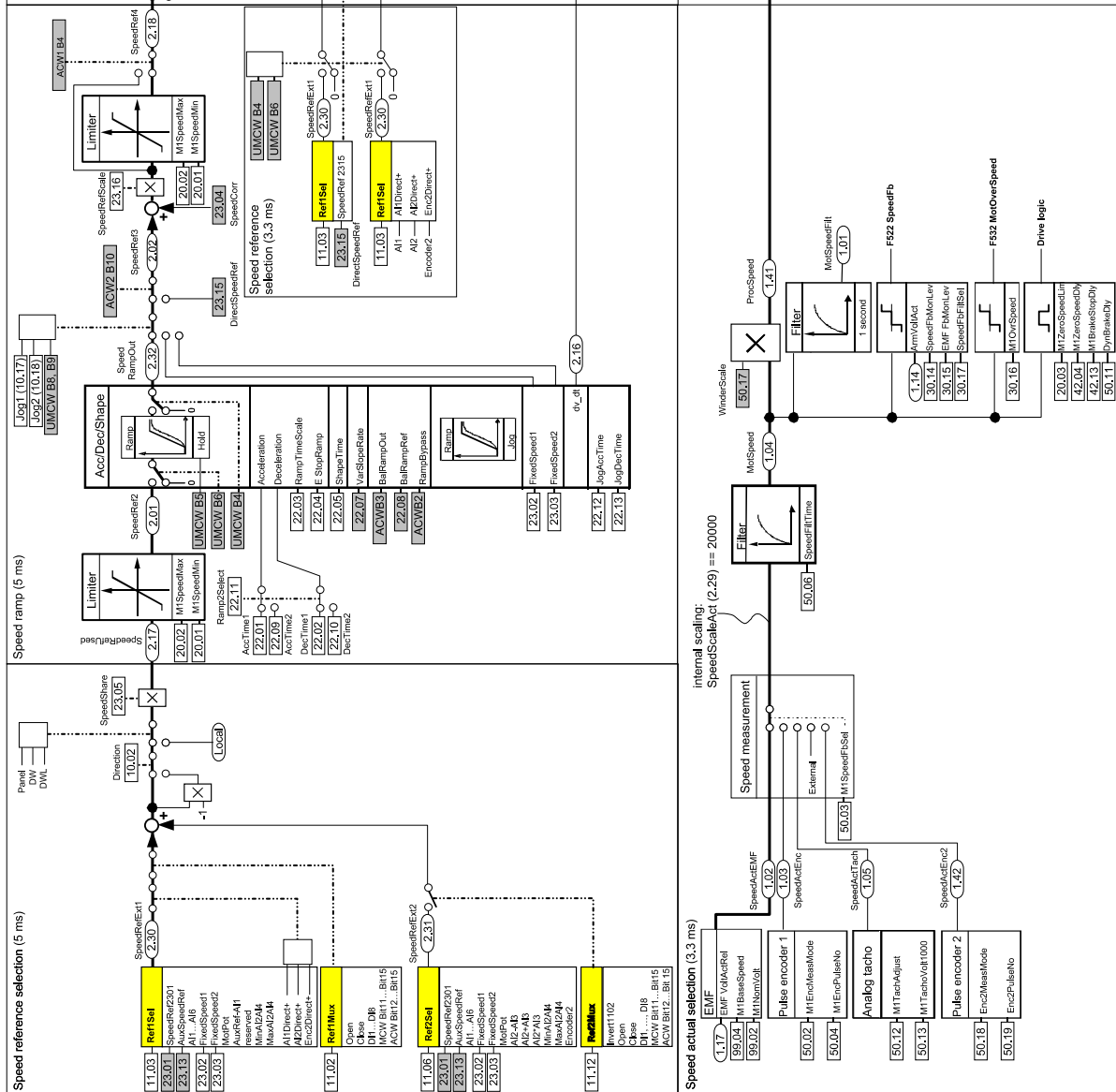

SPEED CONTROL

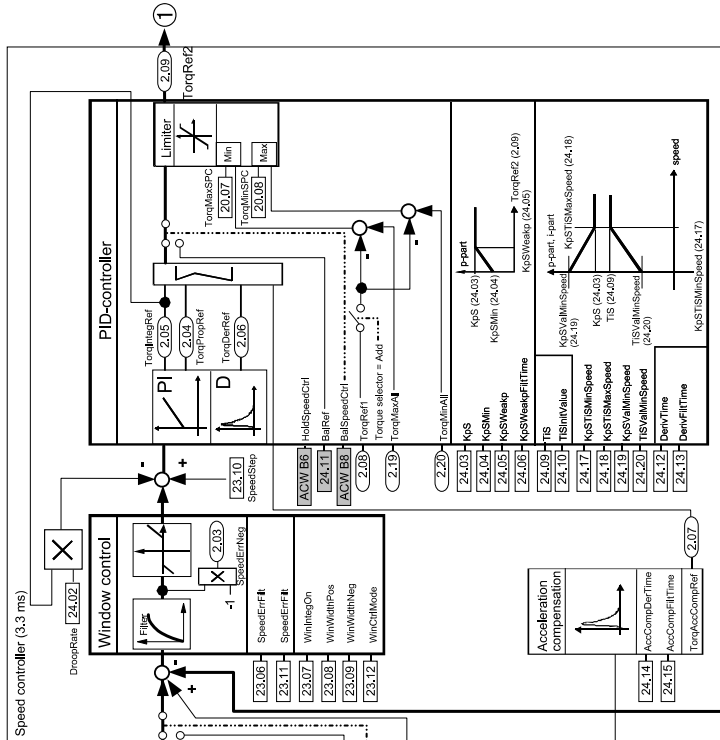

Legend

- ◯ 2.19- Signal
- ◯ 24.13- Parameter

Parameter is usually written to by Adaptive Program, application program or overriding control

Attention:
The firmware structure diagrams show the **standard** firmware

DCS800_Fw_structure_diagram_rev_9.dwg

TORQUE CONTROL CHAIN



ABB Drive profile control

Bit	ACW1	ACW2	MCW	MCW	UMCW	Drive Logic	CurCrtStat1	MainStatWord (MSW)	AuxStatWord (ASW)
7.02	Bit0 RestartDataLog	Bit0 On (OffIN)	Bit0 On (OffIN)	Bit0 On (OffIN)	Bit0 On (OffIN)	Faults	Bit0 FansOn Cmd.	Bit0 RdyOn	Bit0 DataLogReady
7.03	Bit1 TrigDataLog	Bit1 reserved	Bit1 Off2N (Coast Stop)	Bit1 Off2N (Coast Stop)	Bit1 Off2N (Coast Stop)	Alarms	Bit1 reserved	Bit1 RdyRun	Bit1 OutOfWindow
	Bit2 RampByPass	Bit2 reserved	Bit2 Off3N (E-Stop)	Bit2 Off3N (E-Stop)	Bit2 Off3N (E-Stop)	MoSpeed	Bit2 reserved	Bit2 RdyRef	Bit2 E-StopCoast
	Bit3 BalRampOut	Bit3 reserved	Bit3 Run	Bit3 Run	Bit3 Run	Off1Mode	Bit3 Tripped	Bit3 User1	Bit3 User1
	Bit4 LimSpeedRef4	Bit4 DisableBridge1	Bit4 RampOutZero	Bit4 RampOutZero	Bit4 RampOutZero	StopMode	Bit4 field direction	Bit4 Off2NStatus	Bit4 User2
	Bit5 reserved	Bit5 HoldSpeedCtrl	Bit5 reserved	Bit5 reserved	Bit5 reserved	E StopMode	Bit5 FieldOn Cmd.	Bit5 Off3NStatus	Bit5 SyncRdy
	Bit6 HoldSpeedCtrl	Bit6 WindowCtrl	Bit6 RampHold	Bit6 RampHold	Bit6 RampHold	E StopMode	Bit6 dynamic braking	Bit6 OnInhibited	Bit6 Flex1Act
	Bit8 BalSpeedCtrl	Bit8 DriveDirection	Bit8 RampInZero	Bit8 RampInZero	Bit8 RampInZero	FlyStart	Bit7 MainContactorOn Cmd	Bit7 Alarm	Bit7 Flex2Ack
	Bit9 SyncCommand	Bit9 reserved	Bit9 Reset	Bit9 Reset	Bit9 Reset	MainContCtrlMode	Bit8 DynamicBrakingOn Cmd	Bit8 AtSetpoint	Bit8 BrakeCmd
	Bit11 ResetSyncRdy	Bit10 DirectSpeedRef	Bit10 Inching1	Bit10 Inching1	Bit10 Inching1	FldHeatSel	Bit9 drive generating	Bit9 Remote	Bit9 Limiting
	Bit12 aux. control	Bit12 ForceBrake	Bit11 Inching2	Bit11 Inching2	Bit11 Inching2		Bit10 DC contactor US	Bit10 AboveLimit	Bit10 TorqCrl
	Bit13 aux. control	Bit13 reserved	Bit10 RemoteCmd	Bit10 RemoteCmd	Bit10 RemoteCmd		Bit11 firing pulses	Bit11 reserved	Bit11 ZeroSpeed
	Bit14 aux. control	Bit14 reserved	Bit11...Bit15 aux. control	Bit11...Bit15 aux. control	Bit11...Bit15 aux. control		Bit12 continuous current	Bit12 reserved	Bit12 EMFSpeed
	Bit15 aux. control	Bit15 ResetPIDCtrl					Bit13 zero current	Bit13 reserved	Bit13 FaultOrAlarm
							Bit14 DC-breaker trip cmd	Bit14 reserved	Bit14 DriveDirectionNeg
							Bit15 DC-breaker trip cmd	Bit15 reserved	Bit15 AutoRecloning

DCS800_Fw_structure_diagram_rev_g.dsf

ARMATURE CURRENT CONTROL

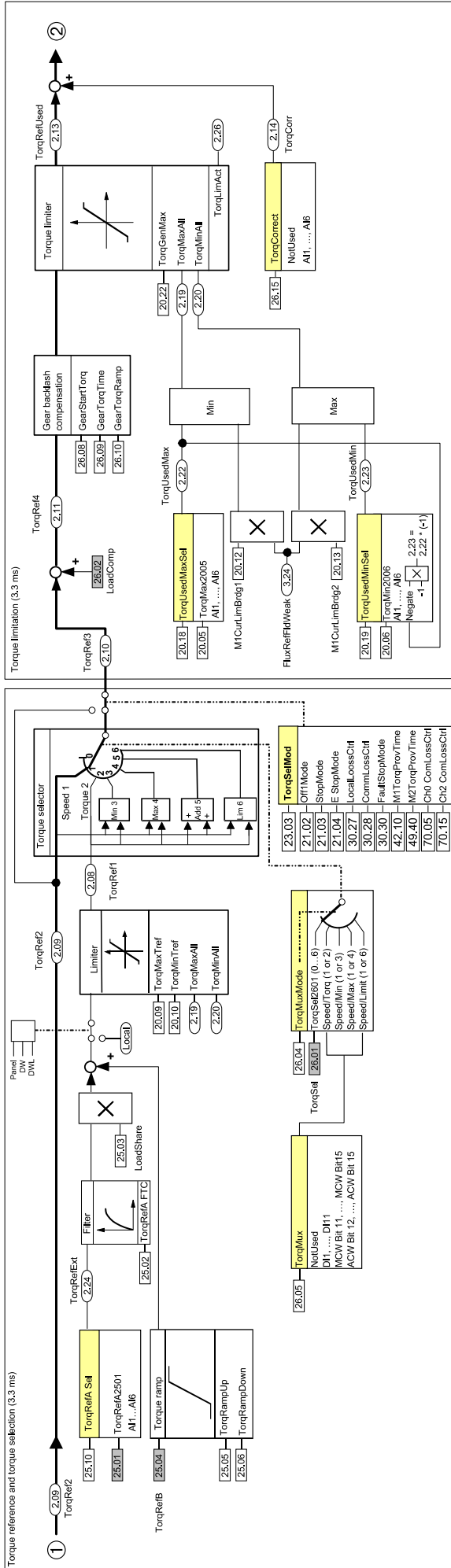
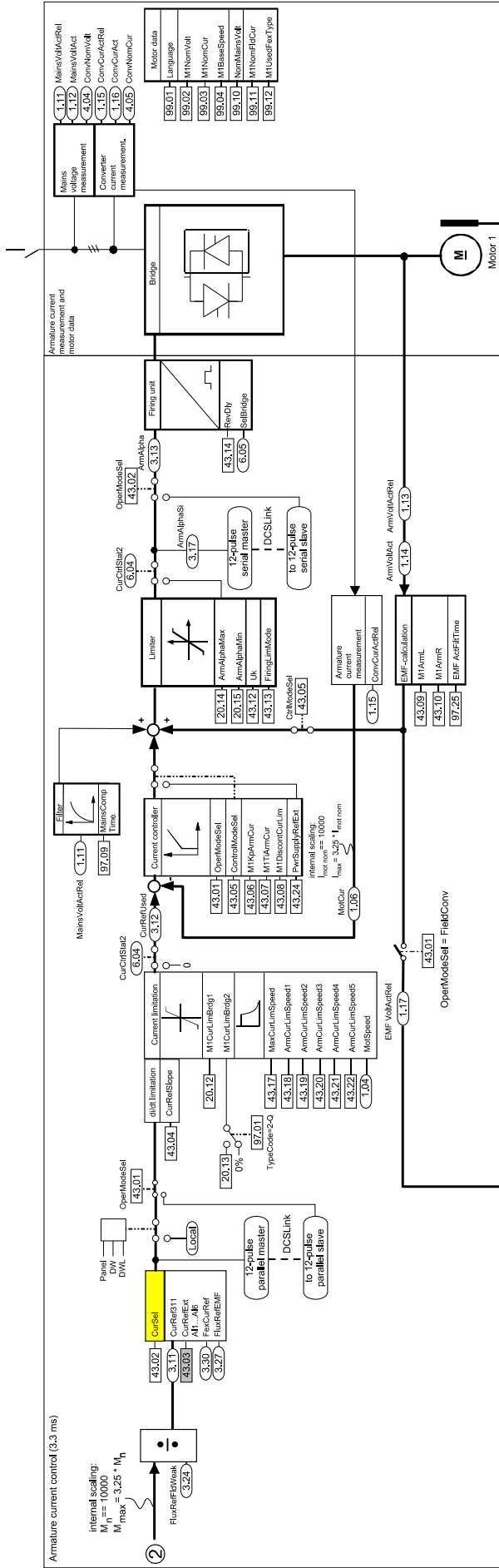

FIELD CURRENT CONTROL (one field exciter)

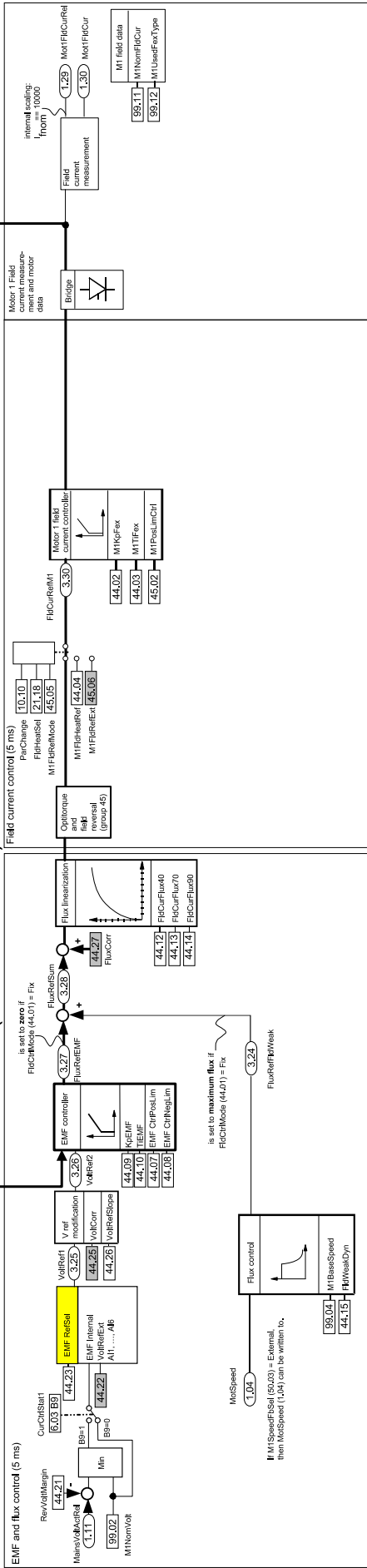

DCS800_Fw_structure_diagram_rev_9.dae

Declaration of Conformity

(Directive 73/23/EEC [Low Voltage], as amended by 93/68/EEC)
(Directive 89/336/EEC [EMC], as amended by 93/68/EEC)

Document code : ABB/DEAPR/AD 06-02

We, ABB Automation Products GmbH
Division Drives & Motors
Wallstadter Str. 59 D68526 Ladenburg, Germany

herewith declare under our sole responsibility, that the product series

DCS 800 Converter Module up to supply voltage of 1000V~

to which this declaration relates, is a BDM / CDM according EN 61800-1: 1998
[IEC 61 800-1]

It is in conformity with

- the **Low Voltage Directive (LVD) 73/23/EEC**, including amendment 93/68/EEC.
Following standards have been applied:

- EN 61800-1: 1998 [IEC 61 800-1]
- EN 60204-1: 1997 [IEC 60 204-1] and

- the **Electromagnetic Compatibility (EMC) Directive 89/336/EEC**, including amendment 93/68/EEC. Following standards have been applied:

- EN 61800-3: 2004 [IEC 61800-3]

This declaration is based on Technical Construction File, code 3ADT061024. It is provided, that instructions for installation, operation and maintenance are according the product documentation.

Ladenburg, 24.03.2006

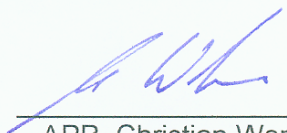

APR Christian Wendler
President



APR / AD Harald Jetses
PRU Manager

This declaration does not express any assurance of characteristics.
Installation and safety instructions mentioned in our installation manual must be obeyed.
The conformity was tested in a typical configuration.



AWQ - 051201

Herstellbescheinigung / Certificate of Manufacture

Datum / date: 01.12.2005

Identifizierung des Produktes / Identification of product

Typ / type : ABB DC Converter Families DCS 400, DCS 500, DCS 600, DCS 800

Prüfung / Test

Die Prüfung erfolgt nach interner, produktspezifischer Prüfanweisung.

Routine test is performed in accordance with ABB product specific test instruction.

Erklärung / Declaration

Wir bestätigen die einwandfreie Herstellung und Prüfung der oben erwähnten Produkte in unserer Fabrik in Lampertheim, Deutschland nach unseren Normen und Sicherheitsvorschriften.

We hereby confirm that the above mentioned products are manufactured and tested in our facility in Lampertheim, Germany in conformity with our standards and safety rules.

ABB Automation Products GmbH
BUU Drives & Motors
Factory Lampertheim

Werksleiter
General Manager



Harald Jetses

Produktionsleiter
Operations Manager



Bernd Schmalenberger

ABB Automation Products GmbH

Für dieses Dokument und den darin dargestellten Gegenstand behalten wir uns alle Rechte vor. Vervielfältigungen, Bekanntgabe an Dritte oder Verwertung seines Inhalts sind ohne unsere ausdrückliche Zustimmung verboten. © ABB Automation Products GmbH 2005

2310

3ADW 000 208 R0101

DCS800 family



DCS800-S modules

The versatile drive for any application

20 ... 5,200 A_{DC}
 0 ... 1,160 V_{DC}
 230 ... 1,000 V_{AC}
 IP00

- Compact
- Highest power ability
- Simple operation
- Comfortable assistants, e.g. for commissioning or fault tracing
- Scalable to all applications
- Free programmable by means of integrated IEC61131-PLC



DCS800-A enclosed converters

Complete drive solutions

20 ... 20,000 A_{DC}
 0 ... 1,500 V_{DC}
 230 ... 1,200 V_{AC}
 IP21 – IP54

- Individually adaptable to customer requirements
- User-defined accessories like external PLC or automation systems can be included
- High power solutions in 6- and 12-pulse up to 20,000 A, 1,500 V
- In accordance to usual standards
- Individually factory load tested
- Detailed documentation



DCS800-E series

Pre-assembled drive-kits

20 ... 2,000 A_{DC}
 0 ... 700 V_{DC}
 230 ... 600 V_{AC}
 IP00

- DCS800 module with all necessary accessories mounted and fully cabled on a panel
- Very fast installation and commissioning
- Squeezes shut-down-times in revamp projects to a minimum
- Fits into Rittal cabinets
- Compact version up to 450 A and Vario version up to 2,000 A



DCS800-R Rebuild Kit

Digital control-kit for existing powerstacks

20 ... 20,000 A_{DC}
 0 ... 1,160 V_{DC}
 230 ... 1,200 V_{AC}
 IP00

- Proven long life components are re-used, such as power stacks, (main) contactors, cabinets and cabling / busbars, cooling systems
- Use of up-to-date communication facilities
- Increase of production and quality
- Very cost-effective solution
- Open Rebuild Kits for nearly all existing DC drives
- tailor-made solutions for...
 - BBC PxD ■ BBC SZxD
 - ASEA TYRAK ■ other manufacturers



ABB Automation Products
 Wallstadter Straße 59
 68526 Ladenburg • GERMANY

Phone +49(0)6203-71-0
 Fax +49(0)6203-71-7609
www.abb.com/motors&drives
dc-drives@de.abb.com