

Pressure/Vacuum Diaphragm Valve deflagration- and endurance burning-proof

PROTEGO® UB/SF

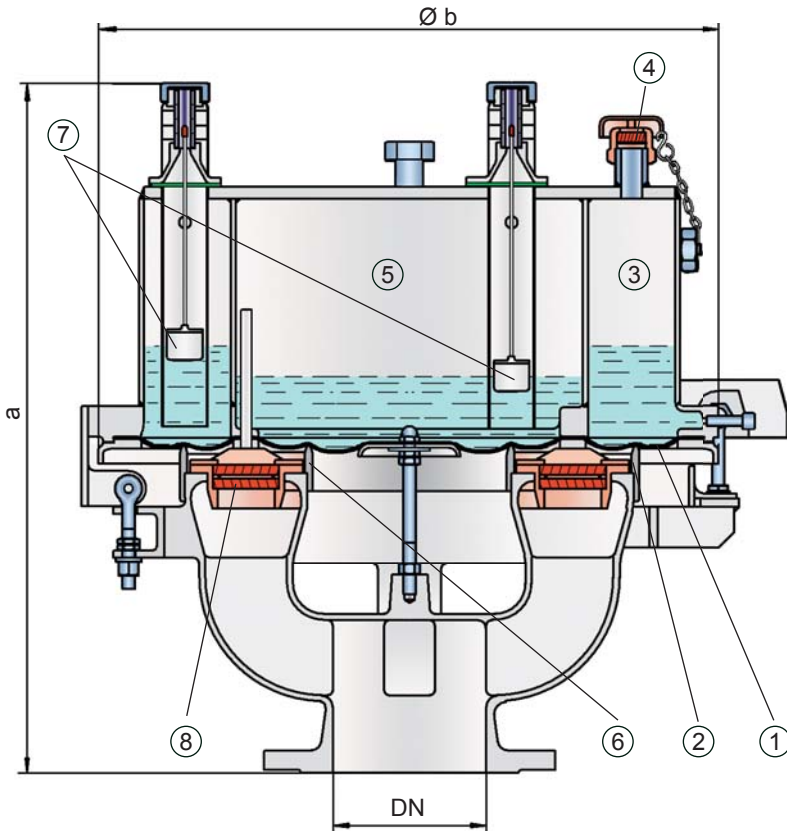

Settings:

| | | | |
|------------------|--------|----------------|-----------------------|
| pressure: | DN 80 | +3.5 mbar | up to +50 mbar |
| | | +1.4 inch W.C. | up to +20 inch W.C. |
| | DN 100 | +3.5 mbar | up to +45 mbar |
| | | +1.4 inch W.C. | up to +18 inch W.C. |
| | DN 150 | +3.5 mbar | up to +46 mbar |
| | | +1.4 inch W.C. | up to +18.4 inch W.C. |

Higher pressure settings up to +140 mbar (56.2 inch W.C.) in special design with additional liquid reservoir as well as lower pressure settings upon request.

| | | |
|----------------|----------------|---------------------|
| vacuum: | -3.5 mbar | up to -35 mbar |
| | -1.4 inch W.C. | up to -14 inch W.C. |

Higher and lower vacuum settings upon request

Function and Description

The deflagration- and endurance burning-proof UB/SF type PROTEGO® diaphragm valve is a state of the art pressure- and vacuum-relief valve combining the function of a dynamic and static flame arrester. Worldwide this design is unique. It is primarily used as a safety device for flame transmission proof in- and outbreathing on tanks, containers and process engineering apparatus. The valve offers reliable protection against excess pressure and vacuum, prevents the inbreathing of air and product losses almost up to the set pressure and protects against atmospheric deflagration and endurance burning if stabilized burning occurs. The PROTEGO® UB/SF diaphragm valve has proven its performance over many years in a great variety of severe applications in the petrochemical and chemical industry. Worldwide it is the only vent which functions in services such as styrene and acrylics.

The set pressure is adjusted with a freeze resistant water-glycol mixture, which assures safe operation under extreme cold weather conditions. The PROTEGO® UB/SF valve is available for substances of explosion group IIB3 (NEC group C MESH ≥ 0.65 mm).

When the pressure in the tank reaches the set pressure, the diaphragm (1) on the outer valve seat ring (2) is lifted and vapours vent to the environment. The set pressure is adjusted by the liquid (water-glycol mixture) column height, which is filled into the outer ring chamber (3). The overpressure chamber is equipped with an opening (4) to keep the pressure in balance with the ambient pressure. The opening is equipped with a FLAMEFILTER® to avoid flame transmission into the overpressure chamber. If a vacuum builds up in the tank, it is transmitted through pressure balancing tubes into the vacuum chamber (5) (inner chamber). If the set vacuum, which depends on the liquid column height in the vacuum chamber, is reached the atmospheric pressure lifts the diaphragm off the inner valve seat ring (6). Ambient air can now flow into the tank. The liquid column heights, which affect the set pressures and vacuum, can be checked by floating level indicators (7).

The tank pressure is maintained up to the set pressure with a tightness that is far superior to the conventional standard due to our highly developed manufacturing technology. This is achieved because the liquid loaded diaphragm presses tightly around the special designed valve seat surface area, even when the operating pressure increases. This is extremely important to reduce leakage to an absolute minimum. After the excess pressure or vacuum is discharged, the valve reseats and provides a tight seal.

If the tank pressure exceeds the adjusted set pressure, explosive gas/product-vapour air mixtures exit. The speed at which these mixtures exit the annular gap between the diaphragm and the outer valve seat ring while overcoming the set pressure is much faster than the flame speed. If this mixture ignites, flashback into the tank is prevented. If the mixture flow continues, the dynamic flame arresting feature prevents flashback ignition even in the case of endurance burning. Even at relatively low flow rates, which occur during thermal outbreathing, the gap formed by the volumetric flow is so narrow that flames are extinguished in the gap and flashback is prevented. At very low pressure settings the explosion pressures resulting from an atmospheric deflagration may be strong enough to lift the diaphragm off the valve seat rings so that flashback could result. The ignition into the tank can be prevented by installing the PROTEGO® flame arrester unit (8). This flame arrester unit provides additional protection against atmospheric deflagration during regular maintenance and inspection.

The valve can be used up to an operating temperature of +60°C / 140°F and meets the requirements of European tank design standard EN 14015 – Appendix L and ISO 28300 (API 2000).

Type-approved in accordance with the current ATEX Directive and EN ISO 16852 as well as other international standards.

Special Features and Advantages

- high performance seal reducing product loss below EPA's 500ppm rule preventing environmental pollution
- set pressure close to opening pressure enables optimum pressure maintenance in the system
- high flow capacity
- can be used as a protective system according to ATEX in areas subject to an explosion hazard
- protection against atmospheric deflagrations and endurance burning for products up to explosion group IIB3 (NEC group C MESH ≥ 0.65 mm)
- minimum pressure drop of the FLAMEFILTER®
- flame-transmission-proof pressure and vacuum chambers
- freeze protection at sub-zero conditions
- self draining function for condensate
- liquid column height is monitored by level indicators
- easy maintenance through hinged vent cap
- modular design enables individual FLAMEFILTER® discs and valve diaphragm to be replaced
- particularly suitable for problematic products such as styrene, acrylics, etc.

Design Types and Specifications

Almost any combination of vacuum and pressure settings can be utilized for the valve. The diaphragm is pressurized by liquid. Higher pressures can be achieved upon request with a special liquid reservoir. When there is a substantial difference between the pressure and vacuum, special designs with weight-loaded vacuum discs are used.

There are two different designs:

Pressure/vacuum diaphragm valve, basic design **UB/SF - □**

Pressure/vacuum diaphragm valve with heating coil **UB/SF - □^H**
(max. heating fluid temperature +85°C / 185°F)

In addition to the standard design, a series of specially developed designs, which are particularly suitable for operating conditions to which these products are subjected, can be provided upon request (for example, for acrylics or styrene storage tanks, etc.).

Remark

$$\text{set pressure} = \frac{\text{opening pressure resp. tank design pressure}}{1,4}$$

Set pressure = the valve starts to open

Opening pressure = set pressure plus overpressure

Overpressure = pressure increase over the set pressure

Table 1: Dimensions

Dimensions in mm / inches

To select the nominal size (DN), please use the flow capacity charts on the following pages

| DN | pressure | 80 / 3" | 100 / 4" | 150 / 6" |
|----|----------------------------------|-------------|-------------|-------------|
| a | up to +28 mbar / +11.2 inch W.C. | 615 / 24.21 | 645 / 25.39 | 680 / 26.77 |
| a | > +28 mbar / +11.2 inch W.C. | 765 / 30.12 | 795 / 31.30 | 830 / 32.68 |
| b | | 410 / 16.14 | 485 / 19.09 | 590 / 23.23 |

Pressure settings > +50 mbar / +20 inch W.C. (DN 80/3"), > +45 mbar / +18 inch W.C. (DN 100/4"), > +46 mbar / +18.4 inch W.C. (DN 150/6") with additional liquid reservoir - dimensions upon request

Dimensions for pressure/vacuum diaphragm valves with heating coil upon request

Table 2: Selection of explosion group

| MESH | Expl. Gr. (IEC/CEN) | Gas Group (NEC) | Special approvals upon request |
|-----------|---------------------|-----------------|--------------------------------|
| ≥ 0,65 mm | IIB3 | C | |



for safety and environment

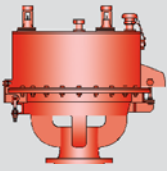

Pressure/Vacuum Diaphragm Valve
deflagration- and endurance burning-proof

PROTEGO® UB/SF

Table 3: Material selection for housing

| | | | |
|----------------------------|-----------------|-----------------|---|
| Design | C | D | Option: Housing with ECTFE-lining Special materials upon request |
| Housing | Steel | Stainless Steel | |
| Valve top | Stainless Steel | Stainless Steel | |
| Heating coil (UB/SF-H-...) | Stainless Steel | Stainless Steel | |
| Valve seats | Stainless Steel | Stainless Steel | |
| Gasket | FPM | PTFE | |
| Diaphragm | A, B | A, B | |
| Flame arrester unit | C | C | |

Table 4: Material selection for diaphragm

| | | | |
|-----------|-----|-----|--------------------------------|
| Design | A | B | Special materials upon request |
| Diaphragm | FPM | FEP | |

Table 5: Material combinations of flame arrester unit

| | | |
|-------------------|-----------------|--------------------------------|
| Design | C | Special materials upon request |
| FLAMEFILTER® cage | Stainless Steel | |
| FLAMEFILTER® | Stainless Steel | |
| Spacer | Stainless Steel | |

Table 6: Flange connection type

| | |
|--------------------------|--------------------------|
| EN 1092-1; Form B1 | other types upon request |
| ASME B16.5; 150 lbs RFSF | |

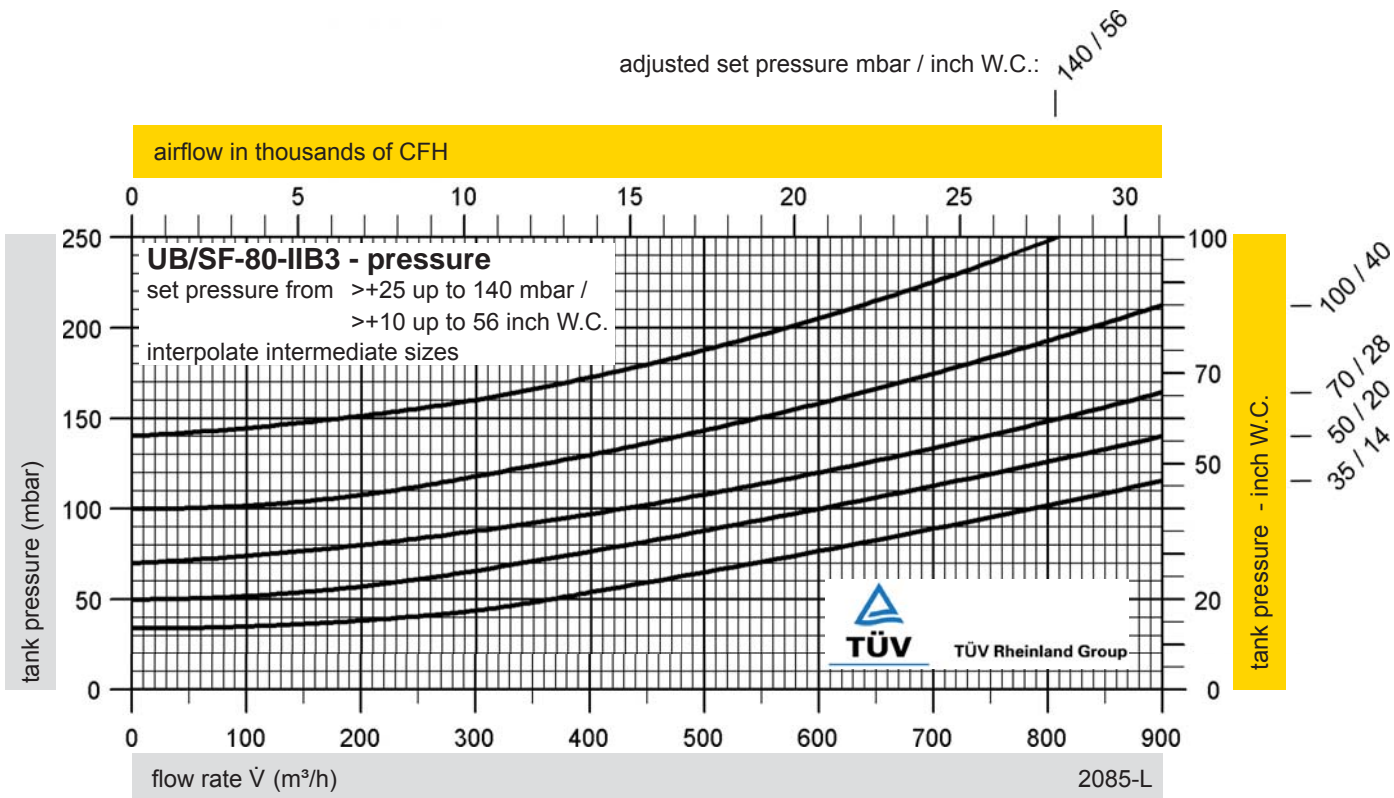
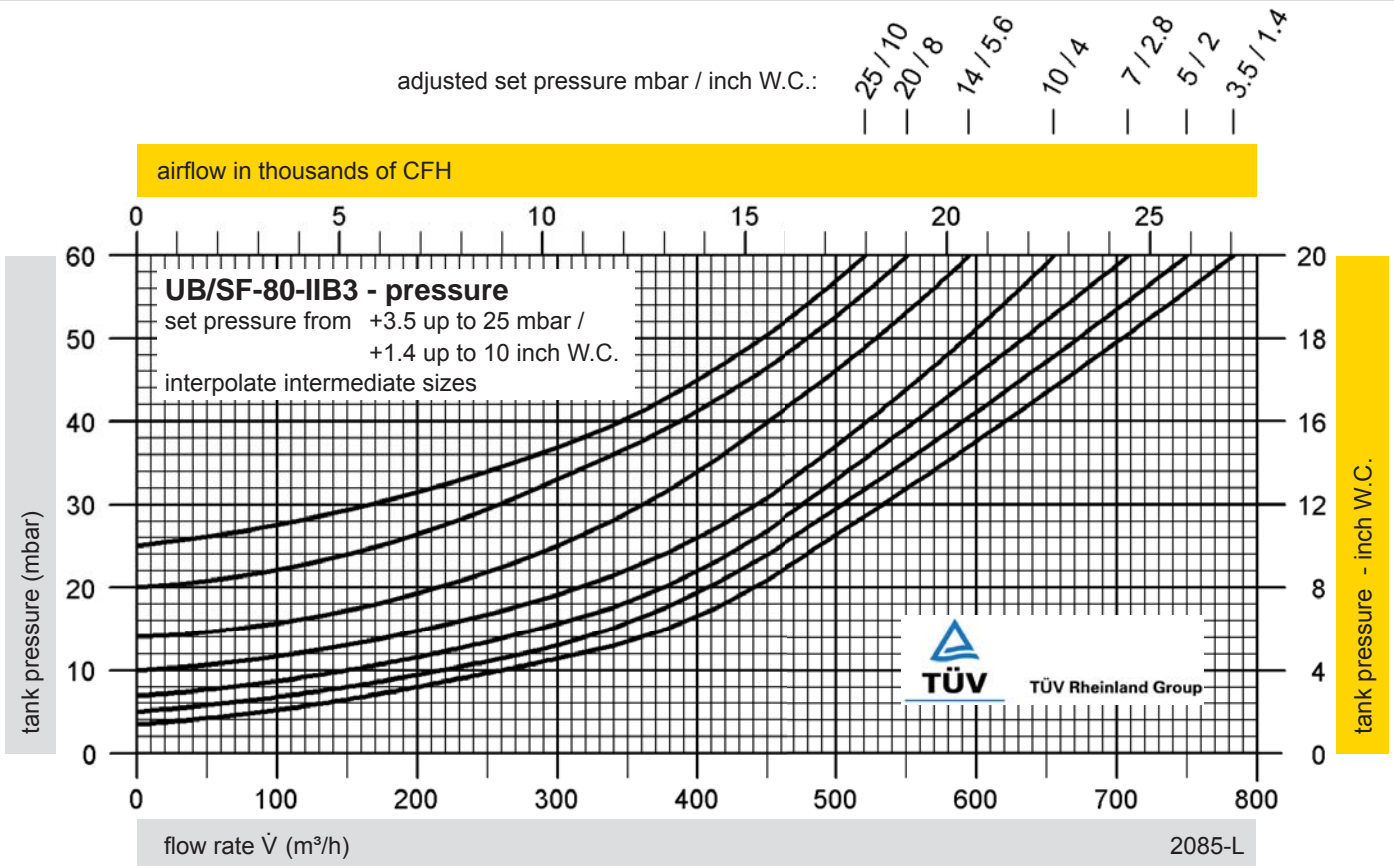

The flow capacity chart has been determined with a calibrated and TÜV certified flow capacity test rig.
 Volume flow \dot{V} in (m³/h) and CFH refer to the standard reference conditions of air ISO 6358 (20°C, 1bar).
 Conversion to other densities and temperatures refer to Vol. 1: "Technical Fundamentals".



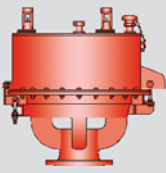

Pressure/Vacuum Diaphragm Valve

Flow Capacity Charts - Pressure

PROTEGO® UB/SF-100

adjusted set pressure mbar / inch W.C.: 25 / 10

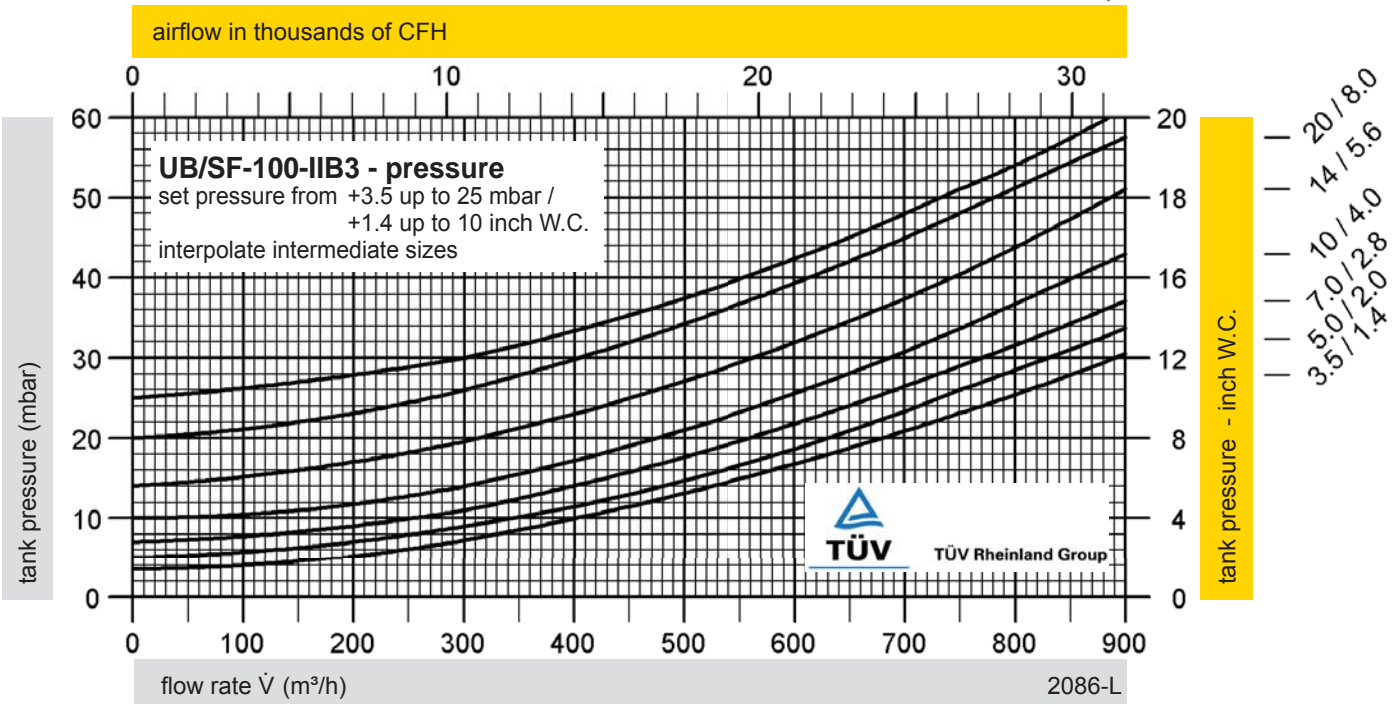

adjusted set pressure mbar / inch W.C.: 140 / 56

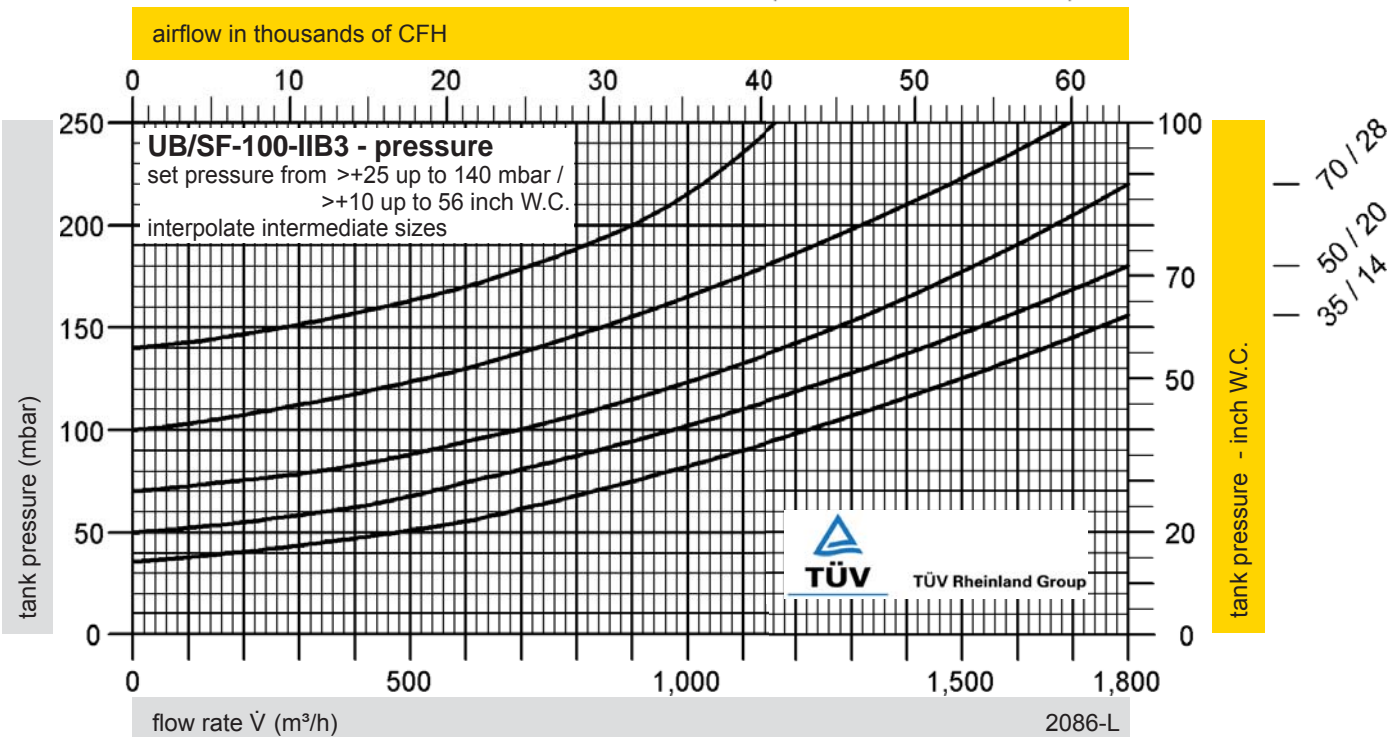

The flow capacity charts have been determined with a calibrated and TÜV certified flow capacity test rig. Volume flow \dot{V} in (m³/h) and CFH refer to the standard reference conditions of air ISO 6358 (20°C, 1bar). Conversion to other densities and temperatures refer to Vol. 1: "Technical Fundamentals".

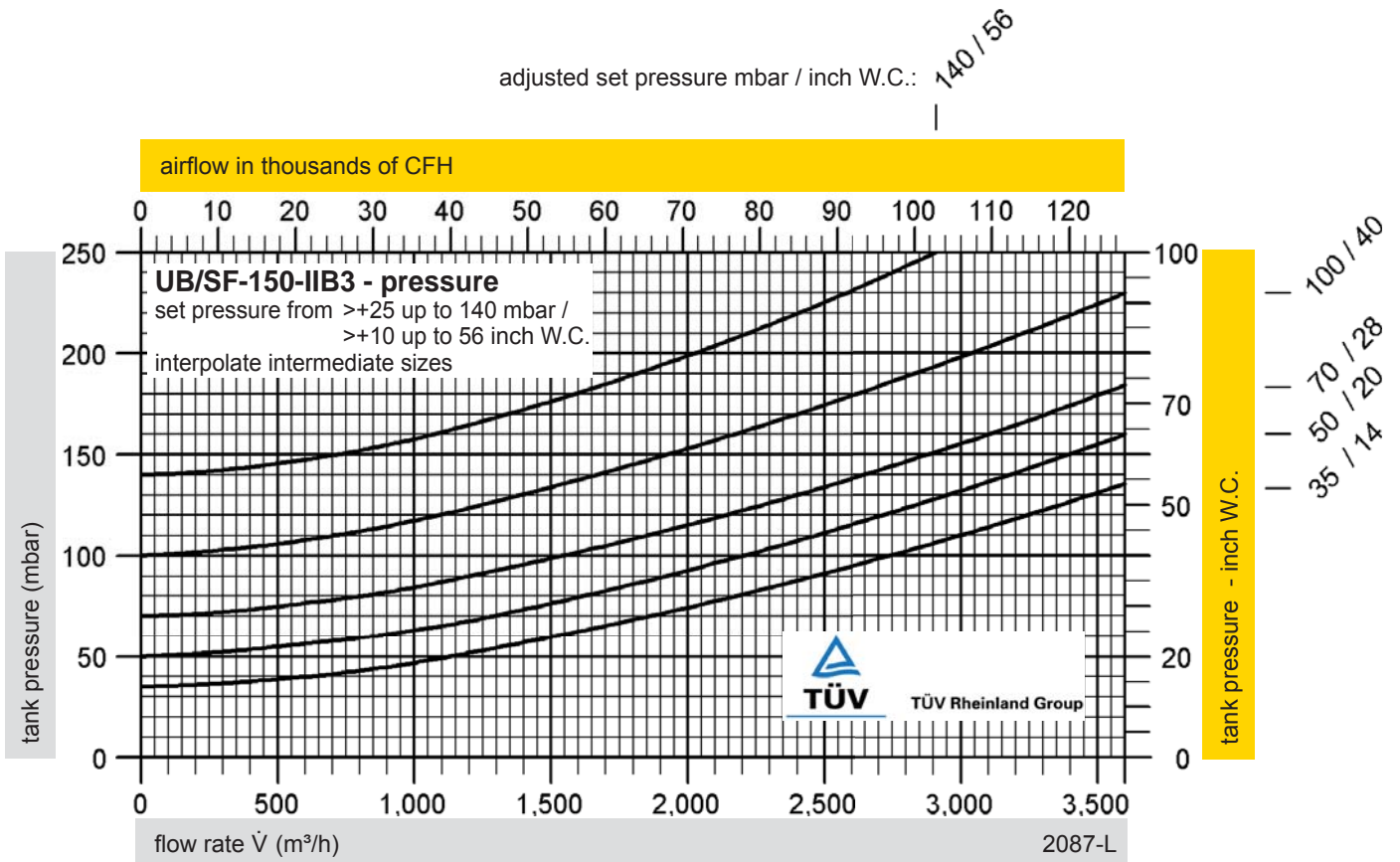
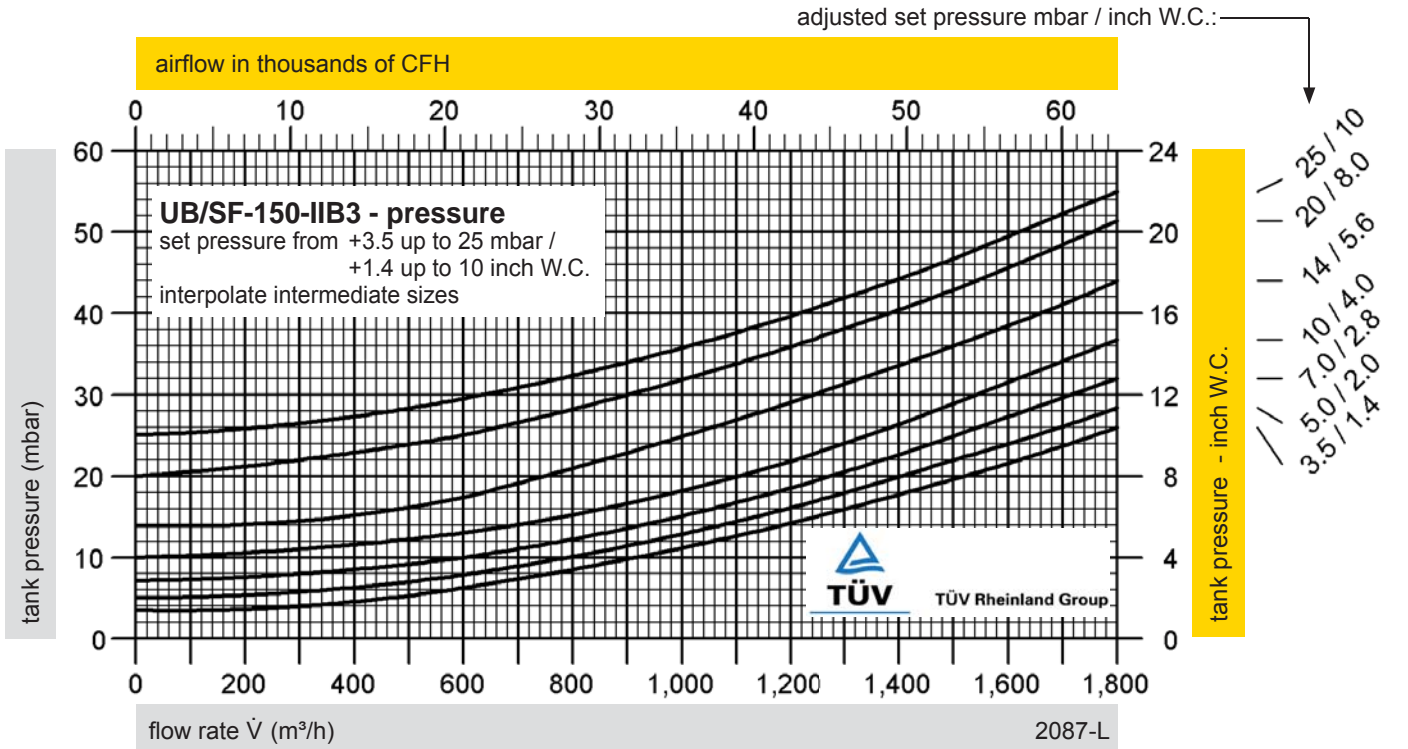

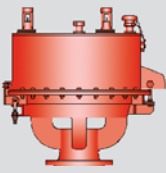

Pressure/Vacuum Diaphragm Valve

Flow Capacity Charts - Vacuum

PROTEGO® UB/SF-80 and 100

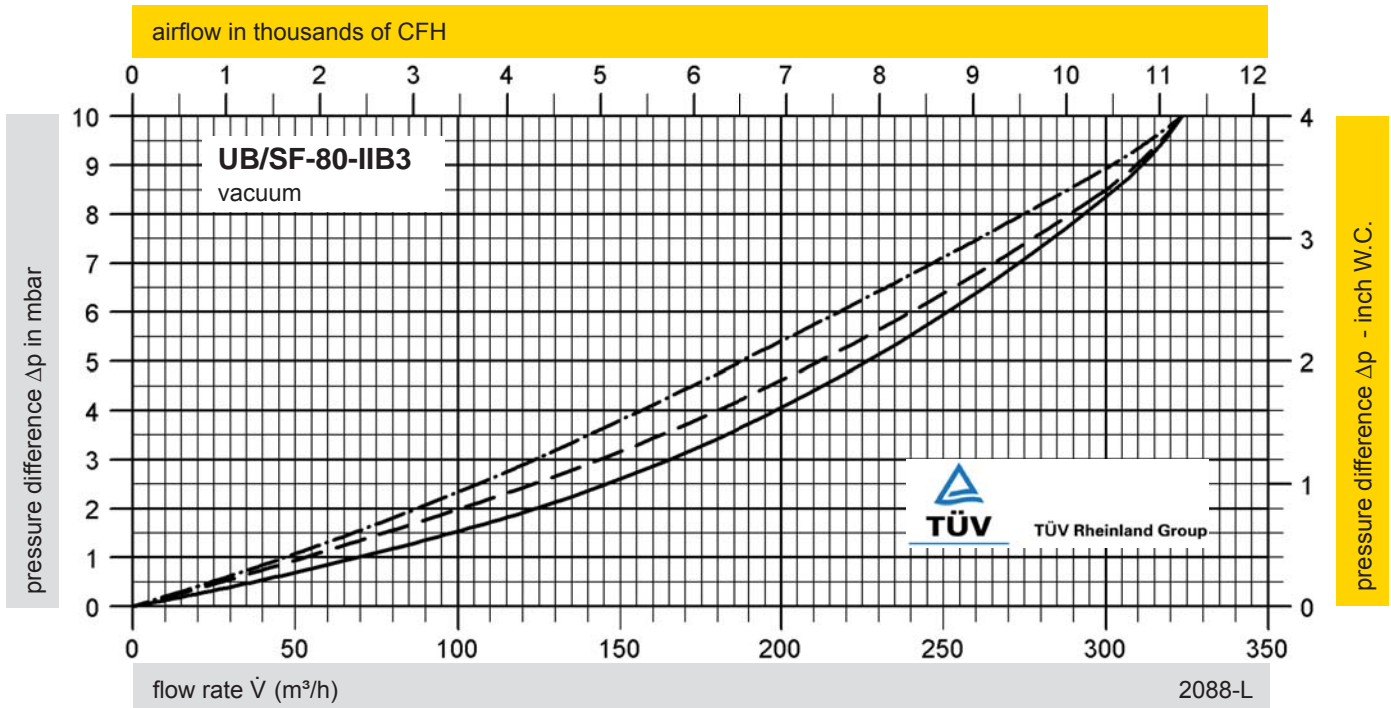

pressure difference = max. allowable tank design vacuum - valve set vacuum

adjusted set vacuum:

- ≤ -5 mbar / ≤ -2 inch W.C.
- - - > -5 mbar up to ≤ -7 mbar / > -2 inch W.C. up to ≤ -2.8 inch W.C.
- · - > -7 mbar up to ≤ -35 mbar / > -2.8 inch W.C. up to ≤ -14 inch W.C.

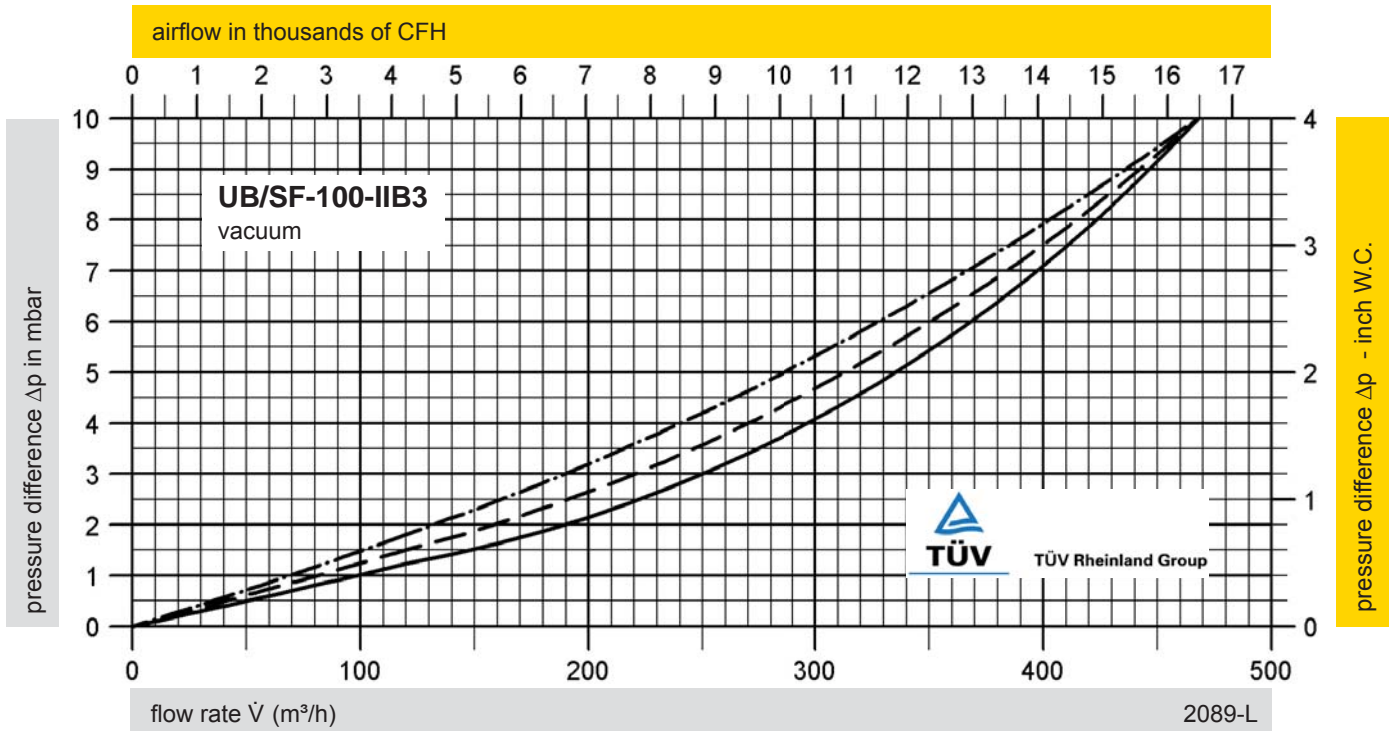

The flow capacity charts have been determined with a calibrated and TÜV certified flow capacity test rig. Volume flow \dot{V} in (m³/h) and CFH refer to the standard reference conditions of air ISO 6358 (20°C, 1bar). Conversion to other densities and temperatures refer to Vol. 1: "Technical Fundamentals".

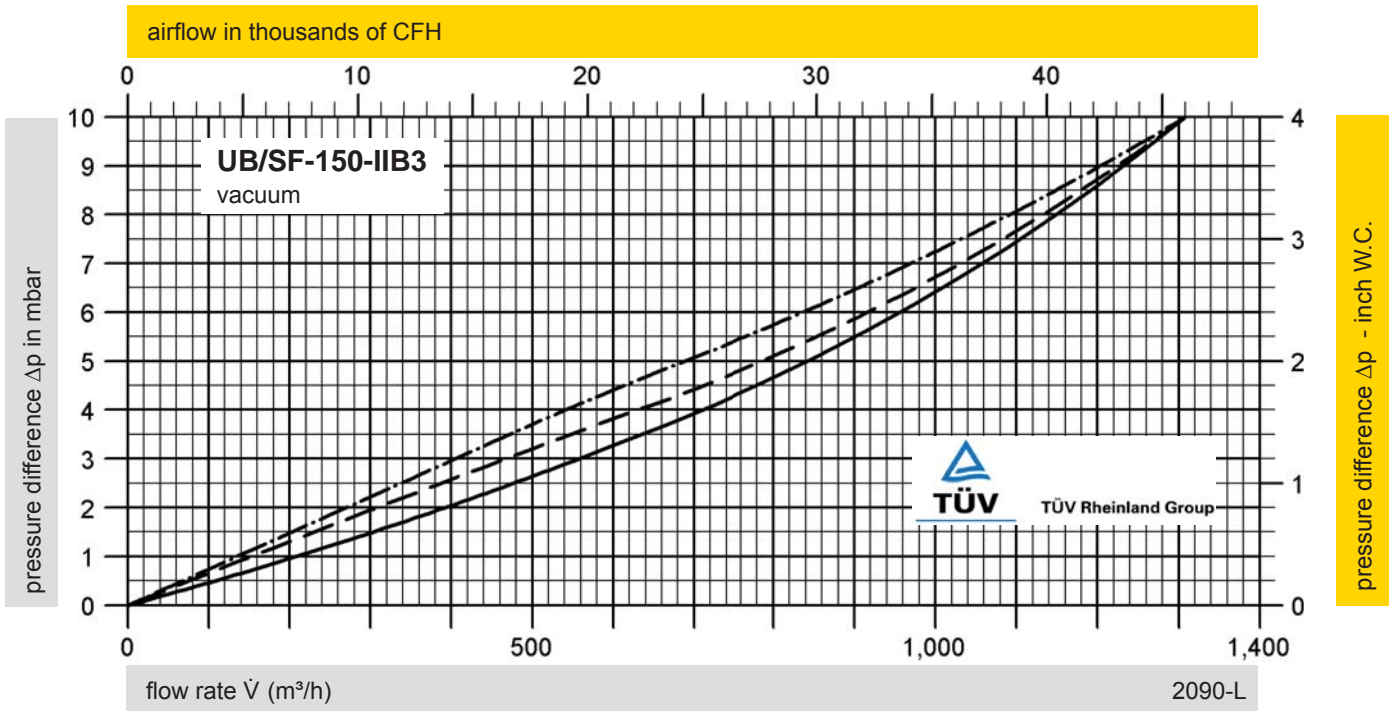

pressure difference = max. allowable tank design vacuum - valve set vacuum

adjusted set vacuum:

- ≤ -5 mbar / ≤ -2 inch W.C.
- - - - - > -5 mbar up to ≤ -7 mbar / > -2 inch W.C. up to ≤ -2.8 inch W.C.
- . - . - > -7 mbar up to ≤ -35 mbar / > -2.8 inch W.C. up to ≤ -14 inch W.C.