

Electrically Heated Vaporizing Pressure-Reducing Regulator (KEV Series)



The KEV series is an electrically heated vaporizing regulator with a low internal volume. It can be used to vaporize liquid samples or to preheat gas samples to prevent them from condensing. It features a heating element that is in direct contact with the process fluid for maximum thermal efficiency and is removable for easy cleaning. The KEV regulator has an integral temperature controller and is rated for use in hazardous areas, as identified below.



Features

- Convolute, nonperforated diaphragm for control ranges up to 500 psig (34.4 bar)
- Stainless steel piston for control ranges from 1000 to 3600 psig (68.9 to 248 bar)
- ATEX, IECEx, and CSA certified for critical/hazardous environments
- T3 temperature classification for all heater ranges
- CE conformity: 89/336/EEC (EMC)
- Horizontally or vertically mounted
- One-piece body eliminates potential leak paths
- Low-volume vapor chamber for fast response
- Heater in direct contact with process media for maximum thermal efficiency
- Removable heater simplifies cleaning
- Side and base inlet options

Technical Data

Maximum Inlet Pressure

- 3600 psig (248 bar)

Pressure Control Ranges

- 0 to 10 psig (0.68 bar) through 0 to 3600 psig (248 bar)

Flow Coefficient (C_v)

- 0.02 or 0.06

Supply-Pressure Effect

Flow Coefficient (C_v)	Pressure Control Range		
	Up to 100 psig (6.8 bar)	250 and 500 psig (17.2 and 34.4 bar)	1000 psig (68.9 bar) and Higher
	Supply Pressure Effect, %		
0.02	0.3	0.5	2.2
0.06	1.0	1.5	7.2

Weight

- Side mounted—8.8 lb (4.0 kg)
- Base mounted—7.7 lb (3.5 kg)

Ports

- 1/8 in. female NPT inlet; 1/4 in. female NPT outlet

Electrical

- Supply—120 and 240 V (ac) ($\pm 10\%$), 50/60 Hz
- Heater ratings—50, 100, 150, and 200 W
- Control temperature range—75 to 380°F (23 to 193°C)
- Explosive atmosphere/hazardous location certification:
 - ATEX (Europe) and IECEx (international)—Group II, Category 2G, Exd IIB+H₂; T3
Ambient temperatures: -4 to 140°F (-20 to 60°C)
 - CSA (Canada and U.S.A.)—Class I, Div 1, Groups B, C, and D; T3; CSA Encl Type 4
Ambient temperatures: -58 to 122°F (-50 to 50°C)

Materials of Construction

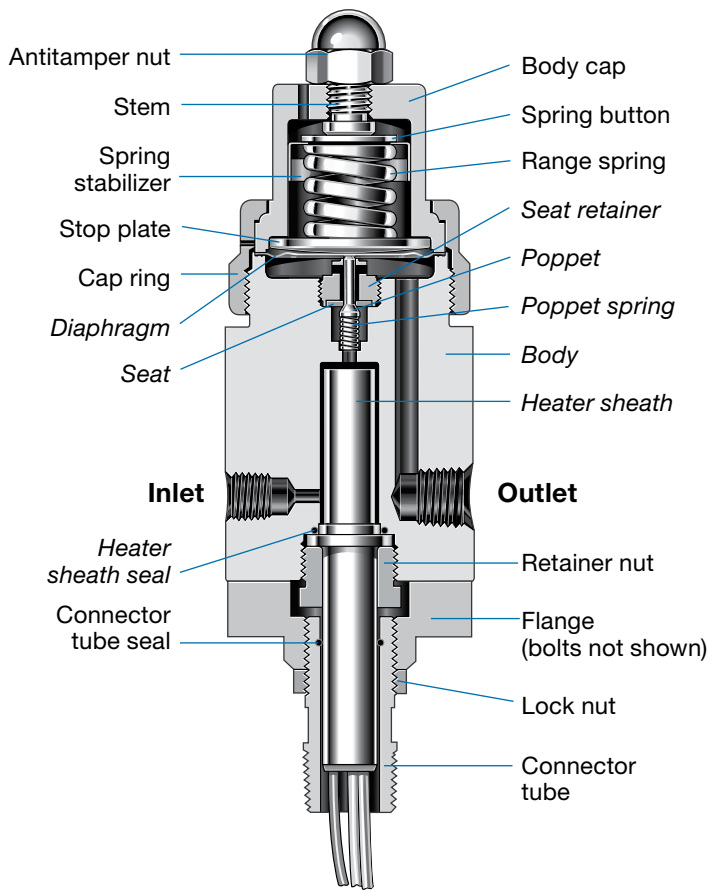

Component	Material
Antitamper nut, stem, cap ring, stop plate, ^① body cap, retainer nut, flange, flange bolts, lock nut, connector tube, panel nuts ^②	316 SS
Spring button	Zinc-plated steel
Spring stabilizer ^③	301 SS
Range spring	316 SS or zinc-plated steel, depending on configuration
Connector tube seal	Nitrile
Nonwetted lubricant	Hydrocarbon-based
<i>Body, seat retainer, heater sheath</i>	316 SS
<i>Heater sheath seal</i>	Alloy 718
<i>Seat</i>	PEEK
<i>Diaphragm^{①④}</i>	Alloy X-750
<i>Poppet</i>	S17400 SS
<i>Poppet spring</i>	302 SS
<i>Wetted lubricant</i>	PTFE-based
Piston Sensing Components	
<i>Piston seal, body seal</i>	PTFE
<i>Piston, piston guide</i>	316 SS
<i>Piston seal retainer</i>	PEEK
<i>Piston seal spring, body seal spring</i>	Elgiloy

Wetted components listed in *italics*.

① Not included in regulators with piston sensing mechanism.

② Not shown.

③ Not required in all configurations.

④ Regulators with control ranges 0 to 250 psig (0 to 17.2 bar) and 0 to 500 psig (0 to 34.4 bar) are assembled with two diaphragms.

Piston Sensing Mechanism

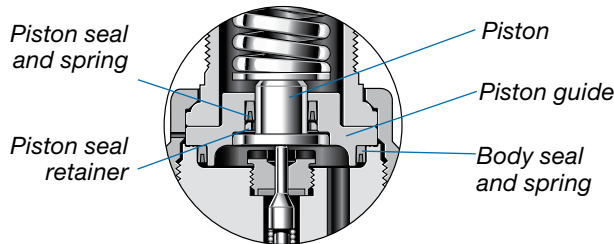

Dimensions

Dimensions, in inches (millimeters), are for reference only and are subject to change.

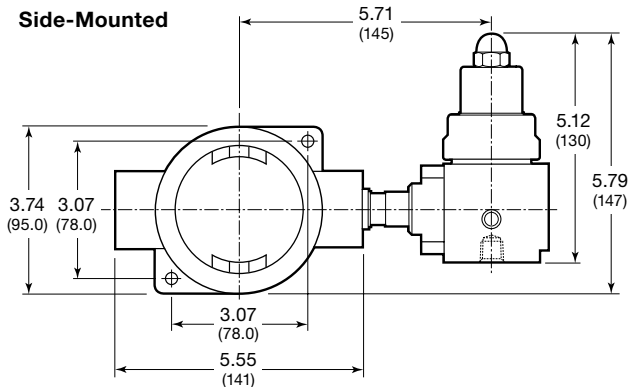

Base-Mounted

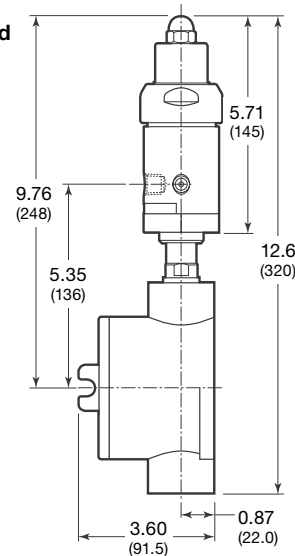

Ordering Information

Build a KEV series regulator ordering number by combining the designators in the sequence shown below.

4 5 6 7 8 9 10 11 12 13 14 15 16
KEV 1 F R A 3 2 2 A X 0 0 0 G

4 Body Material

- 1 = 316 SS
- A = 316 SS, ASTM G93 Level E-cleaned

5 Pressure Control Range

Diaphragm Sensing

- C = 0 to 10 psig (0 to 0.68 bar)
- D = 0 to 25 psig (0 to 1.7 bar)
- E = 0 to 50 psig (0 to 3.4 bar)
- F = 0 to 100 psig (0 to 6.8 bar)
- G = 0 to 250 psig (0 to 17.2 bar)
- J = 0 to 500 psig (0 to 34.4 bar)

Piston Sensing

- L = 0 to 1000 psig (0 to 68.9 bar)
- M = 0 to 1500 psig (0 to 103 bar)
- N = 0 to 2000 psig (0 to 137 bar)
- P = 0 to 3000 psig (0 to 206 bar)
- R = 0 to 3600 psig (0 to 248 bar)

6 Maximum Inlet Pressure^①

- F = 100 psig (6.8 bar)^②
- J = 500 psig (34.4 bar)^②
- L = 1000 psig (68.9 bar)^②
- R = 3600 psig (248 bar)

^① For better resolution and control, select a pressure that closely matches system pressure.
^② Available with diaphragm sensing mechanism only.

7 Port Configuration

- Side Mount—A, X, 1, 2
 - Base Mount—A, B, X, Y, Z
- See **Port Configurations**, below.

8 Ports

- 3 = 1/8 in. female NPT inlet;
- 1/4 in. female NPT outlet(s)

9 Seat Material

- 2 = PEEK

10 Flow Coefficient (C_v)

- 1 = 0.02
- 2 = 0.06

11 Sensing Mechanism

- A = Alloy X-750 diaphragm (outlet pressures up to 500 psig [34.4 bar])
- P = 316 SS piston (outlet pressures above 500 psig [34.4 bar])

12 Handle, Mounting

- W = Antitamper nut, side mount
- X = Antitamper nut, base mount

13 Valves

- 0 = No valves

14 Cylinder Connections

- 0 = No connections

15 Gauges

- 0 = No gauges

16 Heater, Controller

- | | |
|---|---|
| 75 to 380°F
(23 to 193°C), 120 V | 75 to 380°F
(23 to 193°C), 240 V |
| G = 50 W | 6 = 50 W |
| H = 100 W | 7 = 100 W |
| J = 150 W | 8 = 150 W |
| K = 200 W | 9 = 200 W |

Port Configurations^①

➔➔➔ Outlet and auxiliary ports on the same face.

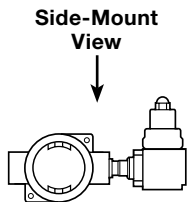

Designator	Configuration
1	Base inlet
2	Base inlet
A	
X	

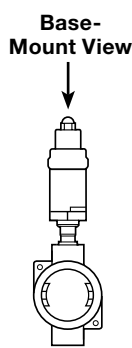

Designator	Configuration
Y	
Z	
A	
X	
B	Aux

^① Regulator is rotatable 360° in relation to terminal box.